

SHEET NO	SHEET NAME
01	INDEX & BLOCK DIAGRAM
02	HDMI CONNECTOR
03	INTEL USB PORT-1
04	INTEL USB PORT-2
05	RS232
06	DEBUG BOARD CONNECTOR
07	MICROCONTROLLER
08	MICROCONTROLLER
09	MICROCONTROLLER
10	RS232 TO USB TRANSLATOR
11	HDMI LEVEL TRANSLATION
12	POWER SUPPLY
13	eJTAG HEADER
14	DEBUG BOARD CONNECTOR-CONTD.,
15	ETHERNET
16	USB3.0
17	HDMI SMBUS CONTROL
18	INTEL DEBUGGER

REVISION HISTORY			
DATE	VERSION	UPDATED BY	REMARKS
26 JAN 2016	1.00		REV A RELEASE
03 MAY 2016	2.00		REV B RELEASE
30 NOV 2016	3.00		REV C RELEASE

HDMI CONN

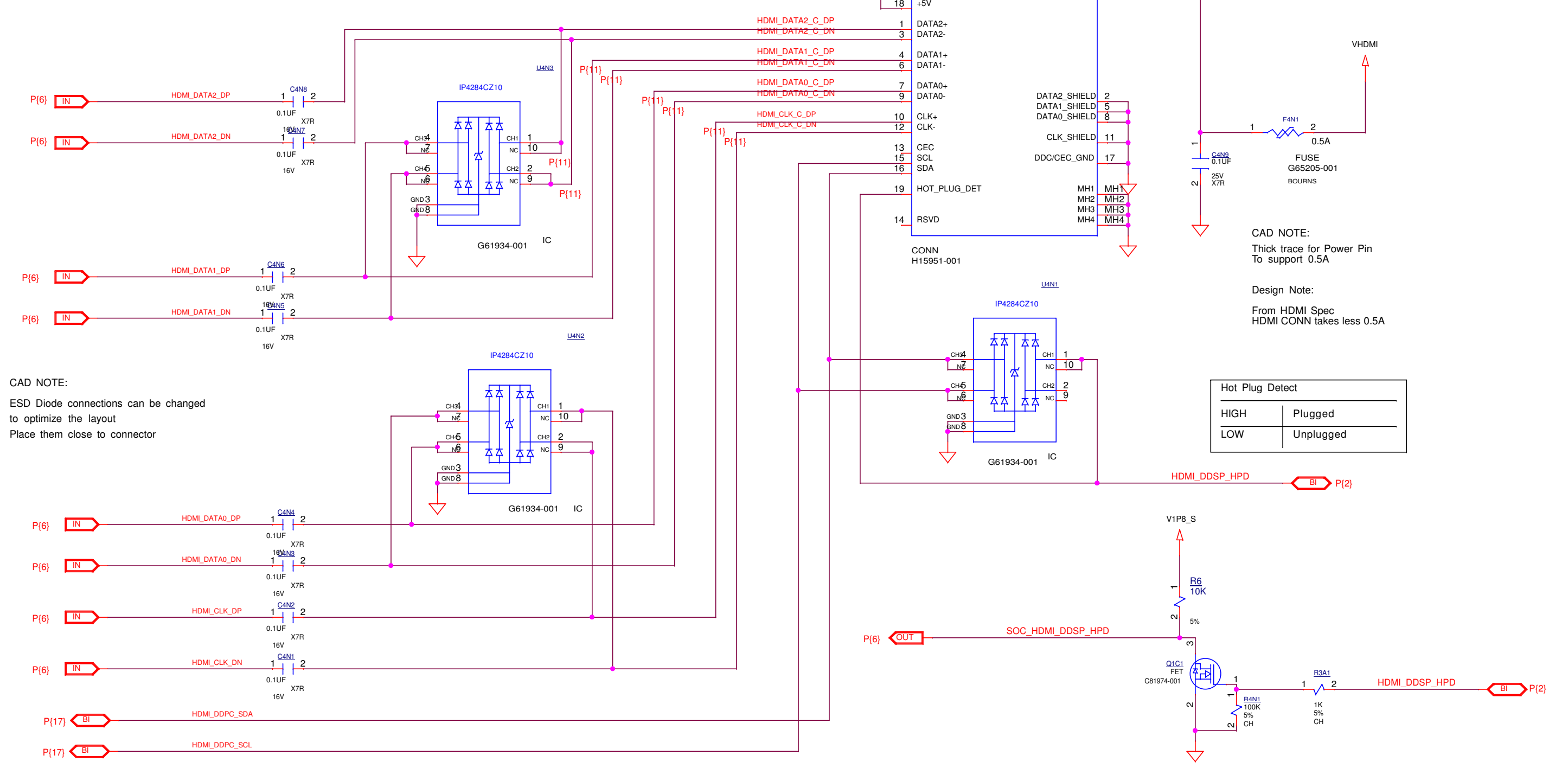

CAD NOTE:
ESD Diode connections can be changed to optimize the layout
Place them close to connector

CAD NOTE:
Thick trace for Power Pin To support 0.5A

Design Note:
From HDMI Spec HDMI CONN takes less 0.5A

Hot Plug Detect	
HIGH	Plugged
LOW	Unplugged

UNLESS OTHERWISE SPECIFIED:
RESISTORS ARE 0402 PACKAGE, POWER RATING < 0.5W & TOLERANCE > 1%
CAPACITORS ARE 0402 PACKAGE & TOLERANCE OF 10%

FACEBOOK CONNECT1		DOCUMENT NUMBER: 00	
TITLE: HDMI_CONNECTOR		LIFE- 3	SHEET 2 OF 18

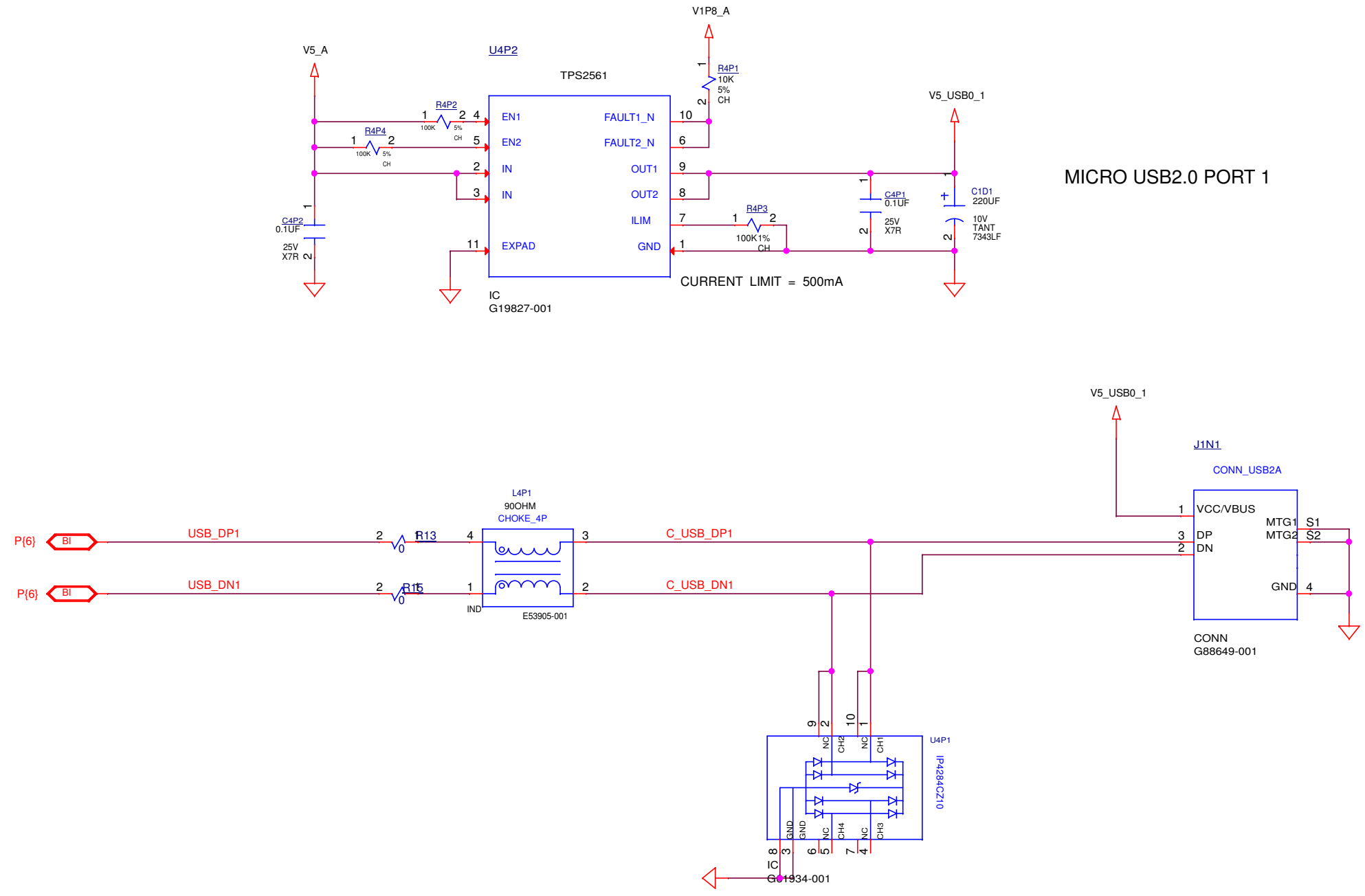

UNLESS OTHERWISE SPECIFIED:
 RESISTORS ARE 0402 PACKAGE, POWER RATING < 0.5W & TOLERANCE > 1%
 CAPACITORS ARE 0402 PACKAGE & TOLERANCE OF 10%

FACEBOOK CONNECT1		DOCUMENT NUMBER: 00	
TITLE: USB2 PORT 1		LIFE- 3	SHEET 3 OF 18

8 7 6 5 4 3 2 1

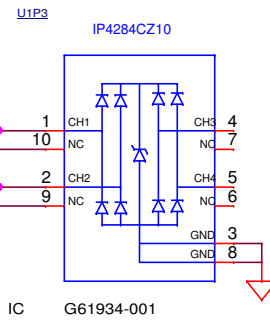
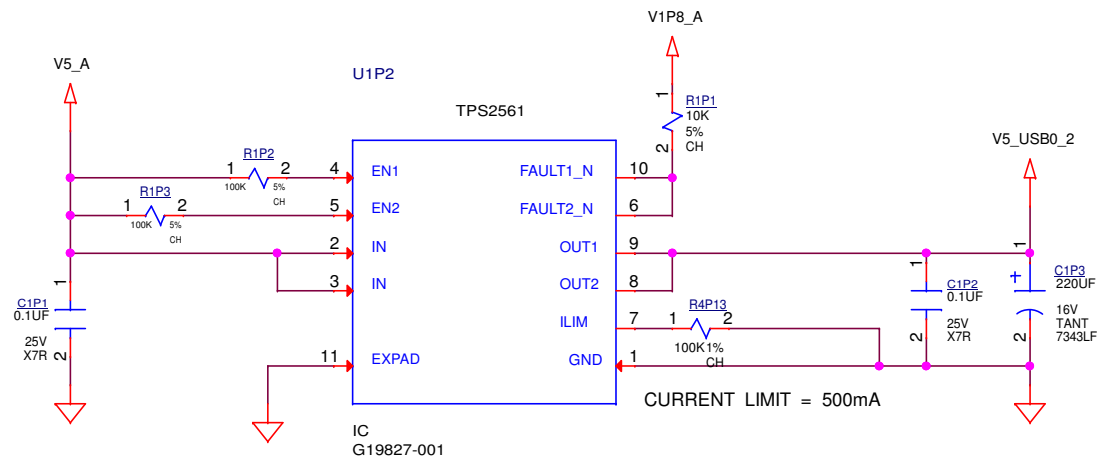

CAD NOTE:
ESD Diode connections can be changed to optimize the layout
Place them close to connector

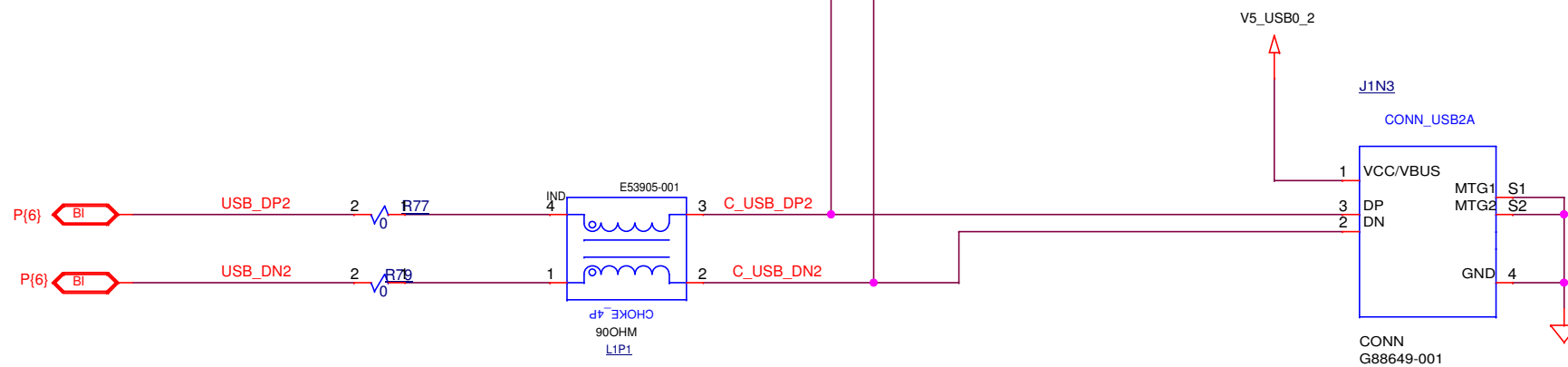

UNLESS OTHERWISE SPECIFIED:
RESISTORS ARE 0402 PACKAGE, POWER RATING < 0.5W & TOLERANCE > 1%
CAPACITORS ARE 0402 PACKAGE & TOLERANCE OF 10%

FACEBOOK CONNECT1		DOCUMENT NUMBER: 00	
TITLE: USB2 PORT 2		LIFE- 3	SHEET 4 OF 18

8 7 6 5 4 3 2 1

RS232

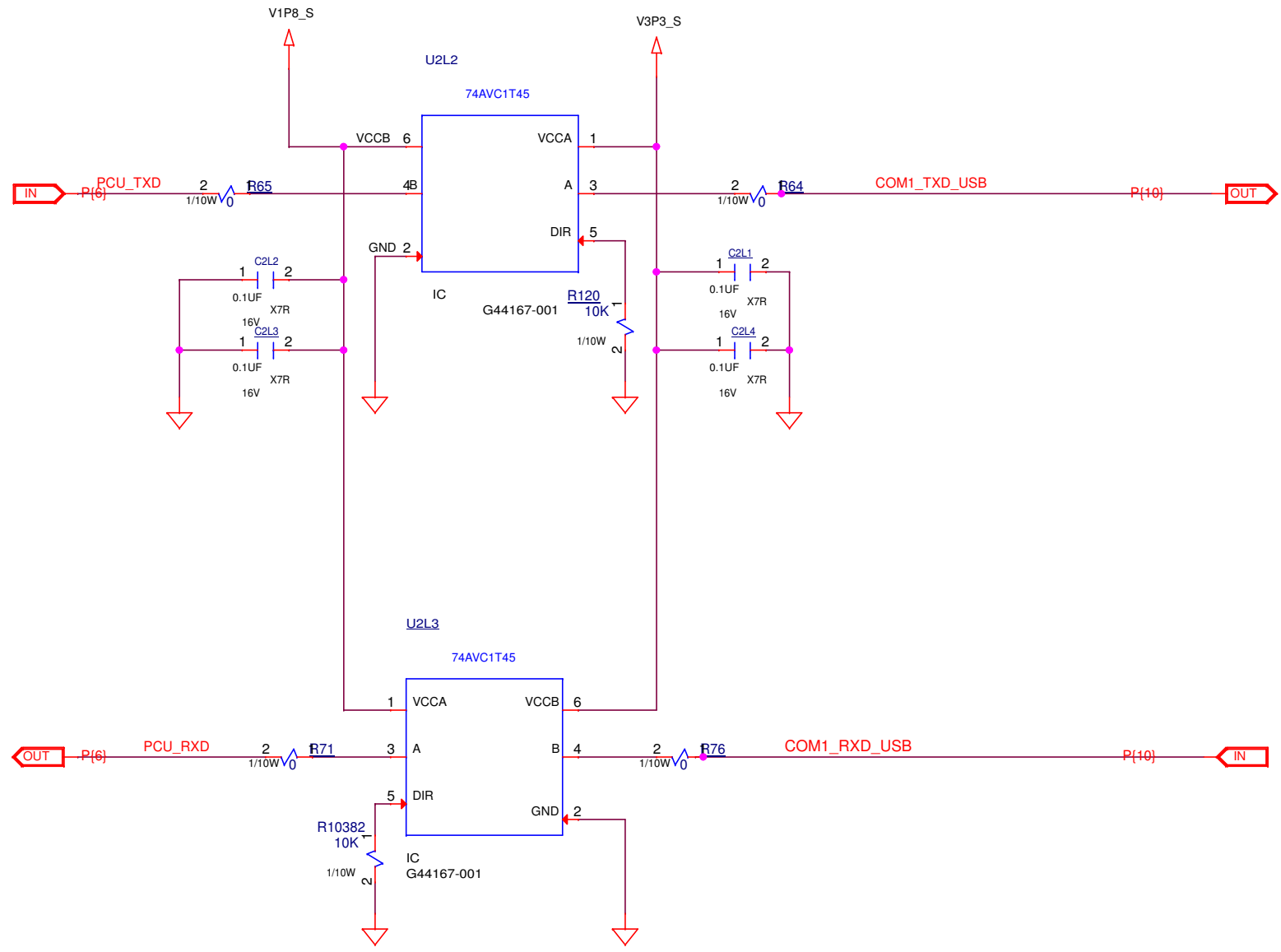

DESIGN NOTE:
LOW ON DIR IS B TO A

UNLESS OTHERWISE SPECIFIED:
RESISTORS ARE 0402 PACKAGE, POWER RATING < 0.5W & TOLERANCE > 1%
CAPACITORS ARE 0402 PACKAGE & TOLERANCE OF 10%

FACEBOOK CONNECT1		DOCUMENT NUMBER: 00
TITLE: RS232	LIFE- 3	SHEET 5 OF 18

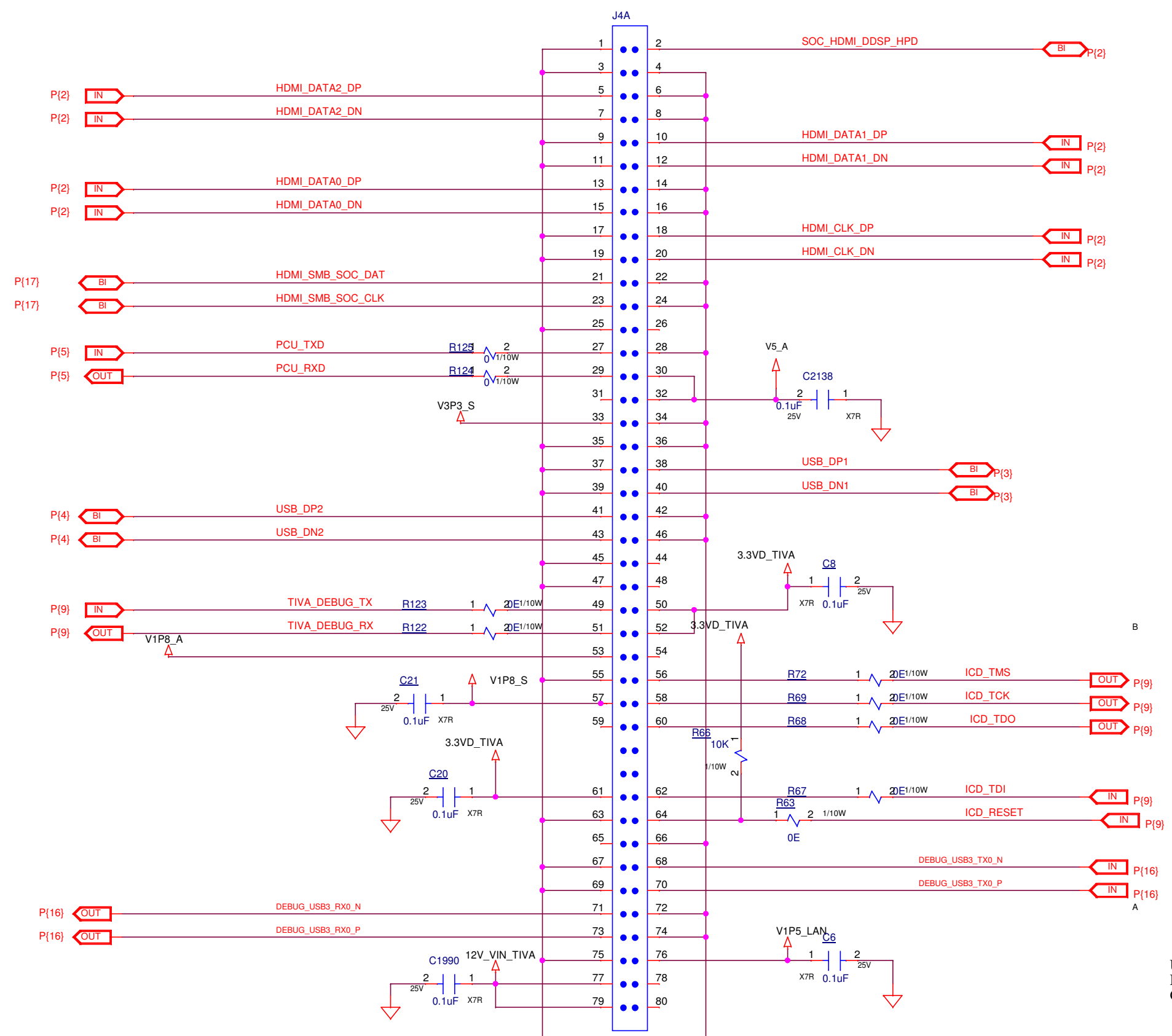

UNLESS OTHERWISE SPECIFIED:
 RESISTORS ARE 0402 PACKAGE, POWER RATING < 0.5W & TOLERANCE > 1%
 CAPACITORS ARE 0402 PACKAGE & TOLERANCE OF 10%

FACEBOOK CONNECT1		DOCUMENT NUMBER: 00	
TITLE: DEBUG CONNECTOR		LIFE- 3	SHEET 6 OF 18

QTE-060-03-L-D-A-GP

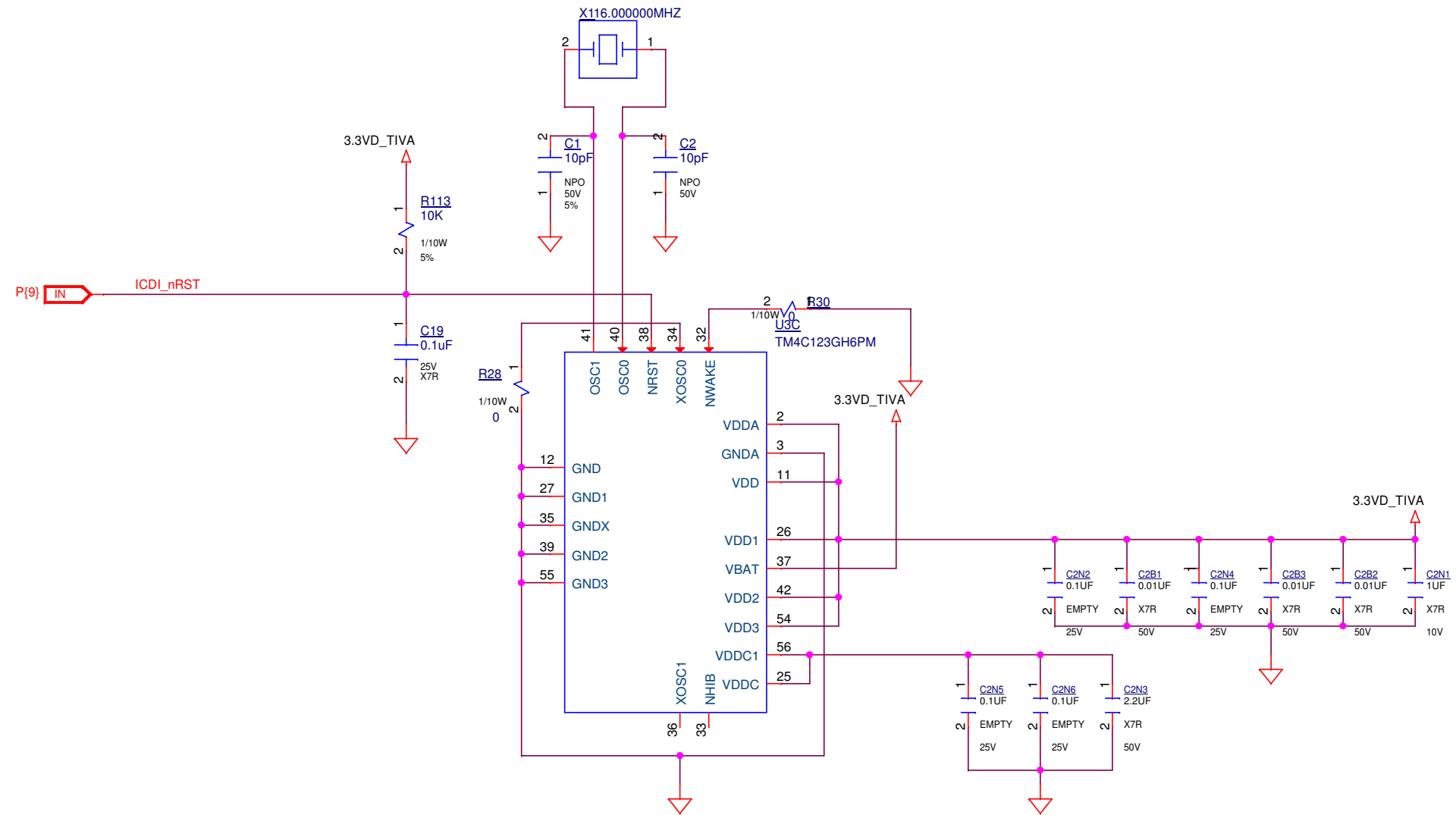

UNLESS OTHERWISE SPECIFIED:
 RESISTORS ARE 0402 PACKAGE, POWER RATING < 0.5W & TOLERANCE > 1%
 CAPACITORS ARE 0402 PACKAGE & TOLERANCE OF 10%

FACEBOOK CONNECT1		DOCUMENT NUMBER: 00	
TITLE: MCU		LIFE- 3	SHEET 7 OF 18

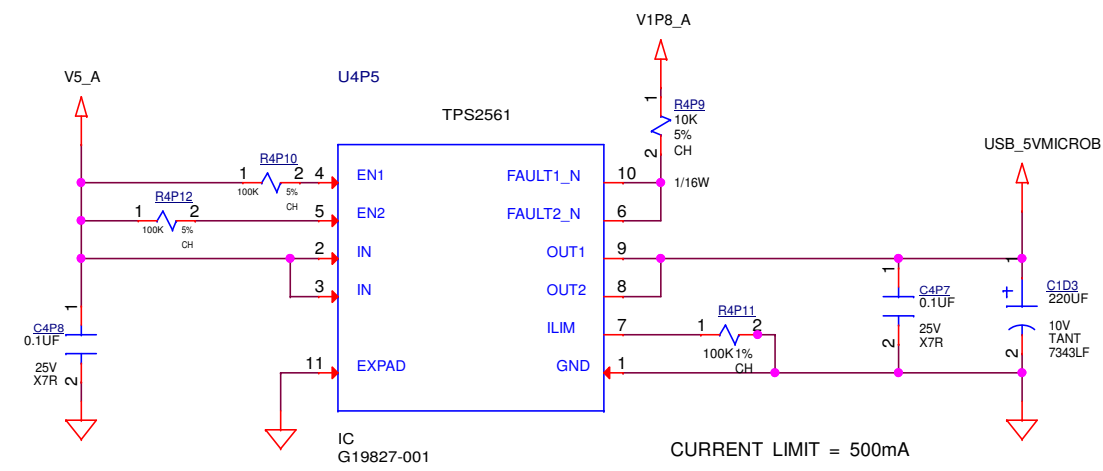

MICRO USB2.0 PORT 1

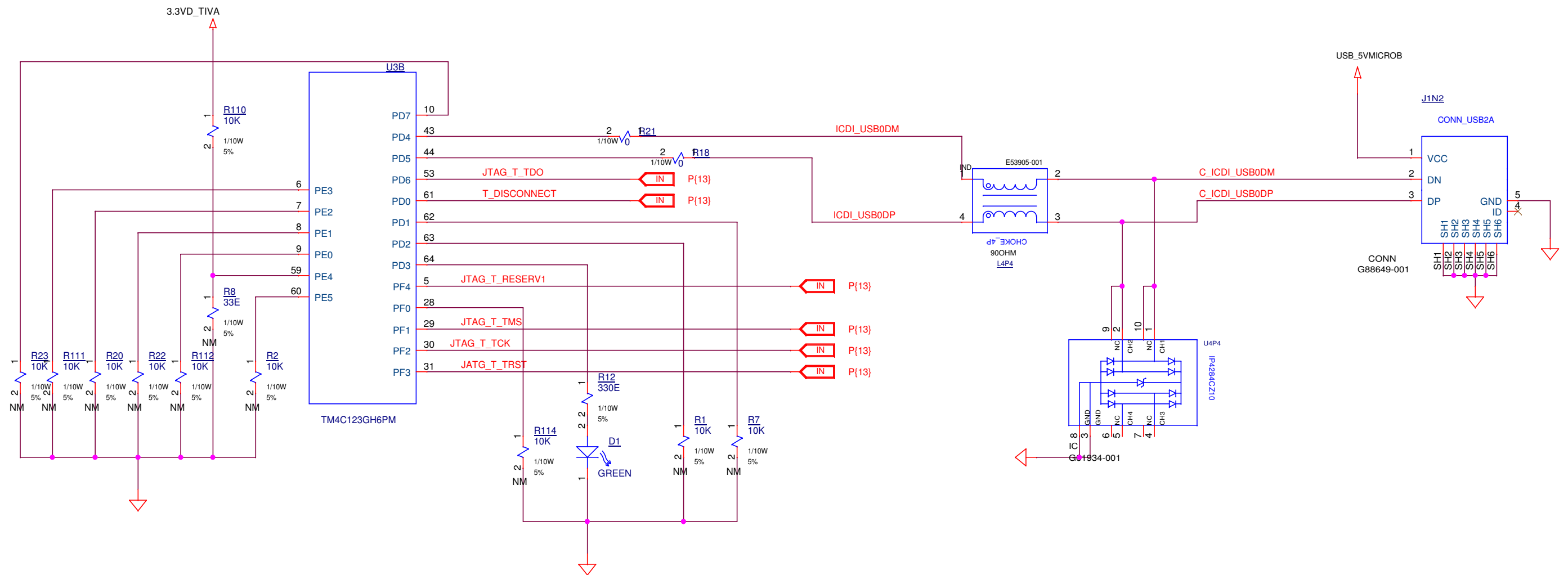

UNLESS OTHERWISE SPECIFIED:
RESISTORS ARE 0402 PACKAGE, POWER RATING < 0.5W & TOLERANCE > 1%
CAPACITORS ARE 0402 PACKAGE & TOLERANCE OF 10%

FACEBOOK CONNECT1		DOCUMENT NUMBER: 00	
TITLE: MCU	LIFE- 3	SHEET 8 OF 18	

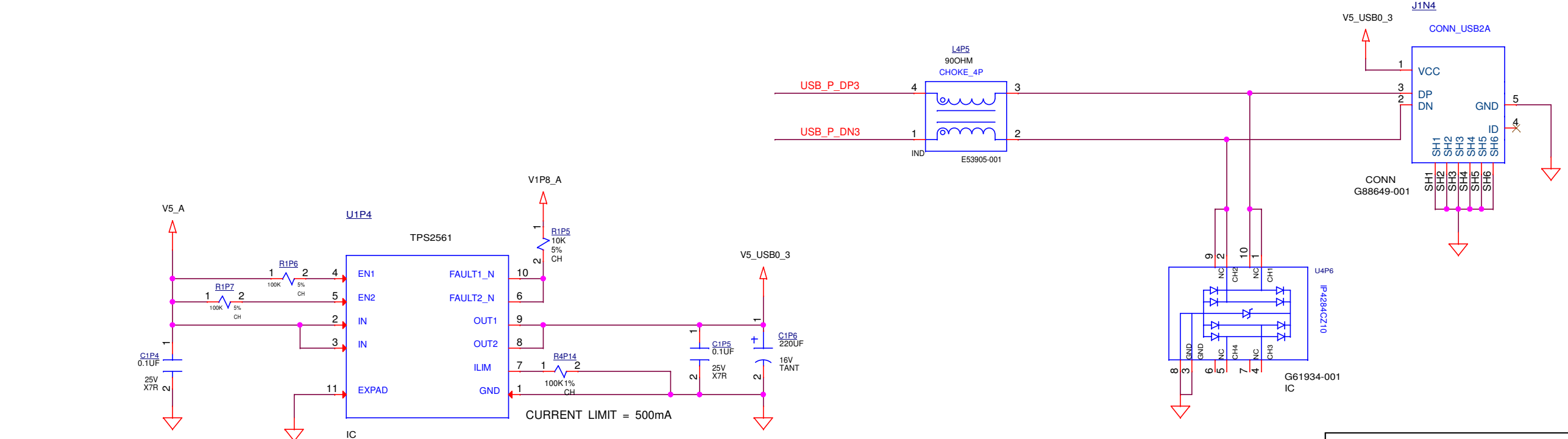
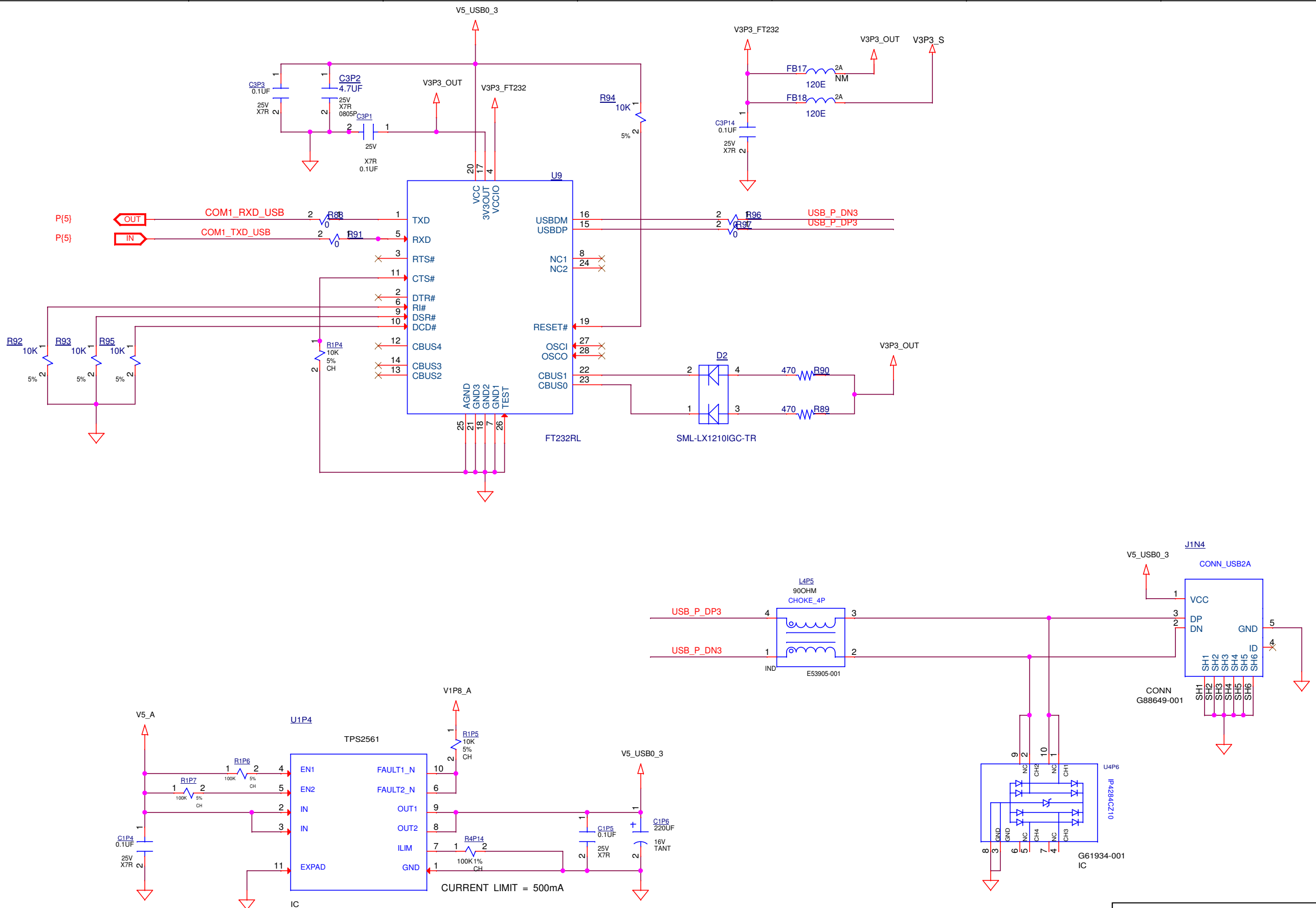

UNLESS OTHERWISE SPECIFIED:
 RESISTORS ARE 0402 PACKAGE, POWER RATING < 0.5W & TOLERANCE > 1%
 CAPACITORS ARE 0402 PACKAGE & TOLERANCE OF 10%

FACEBOOK CONNECT1		DOCUMENT NUMBER: 00	
TITLE: RS232 TO USB		LIFE- 3	SHEET 100F 18

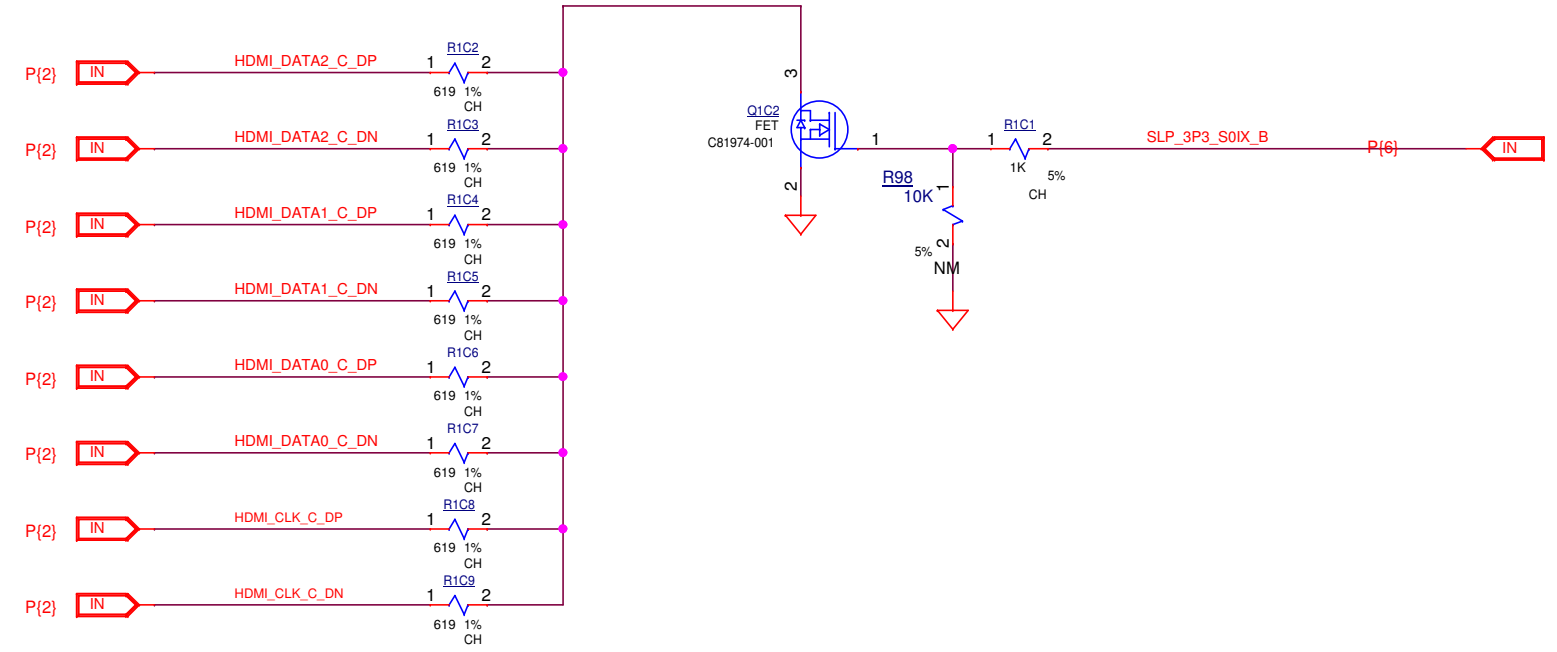
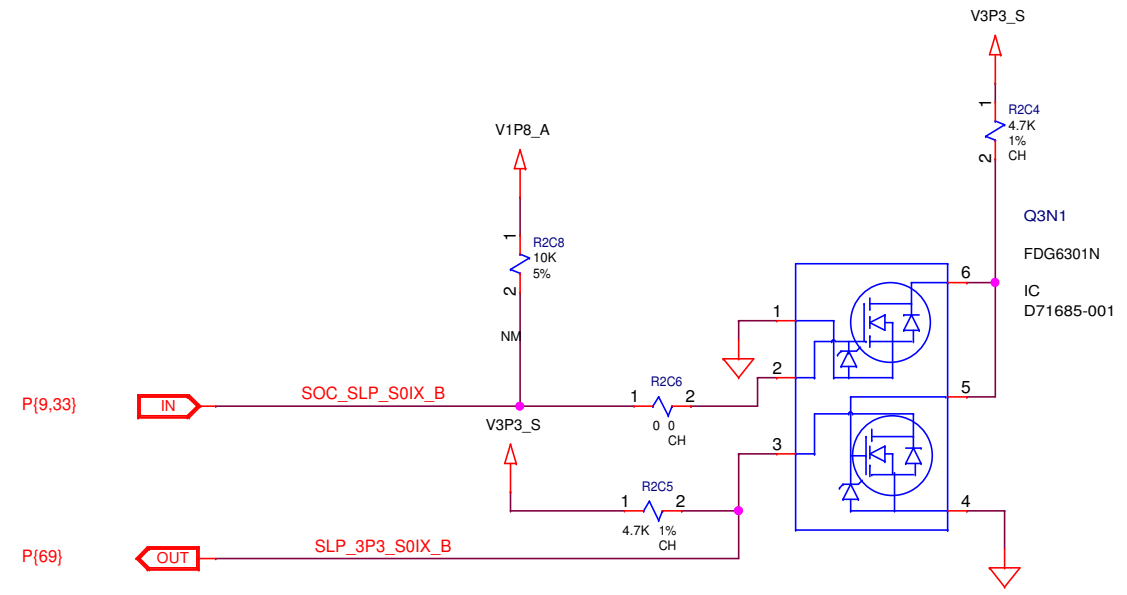
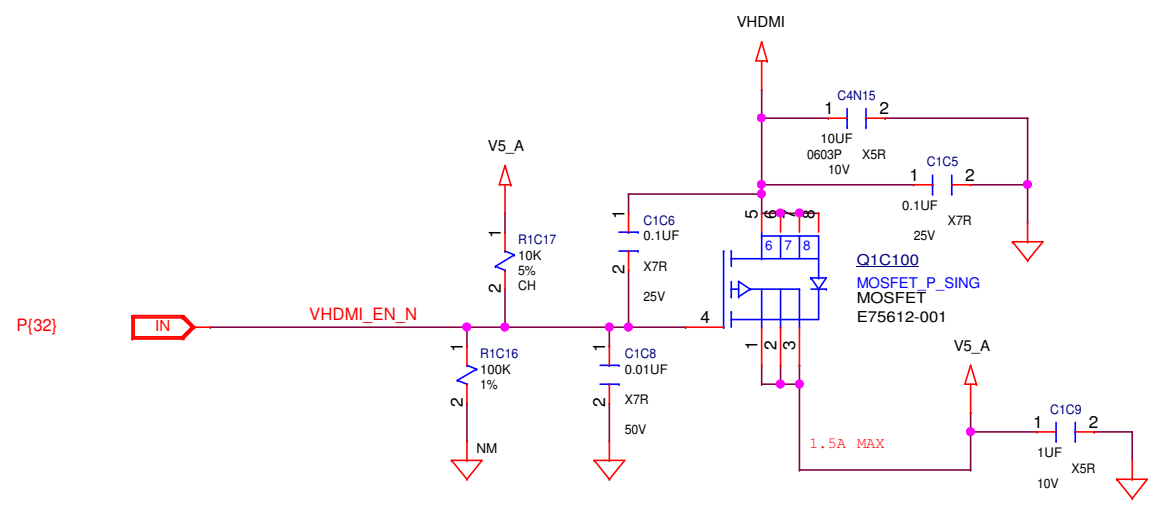

UNLESS OTHERWISE SPECIFIED:
 RESISTORS ARE 0402 PACKAGE, POWER RATING < 0.5W & TOLERANCE > 1%
 CAPACITORS ARE 0402 PACKAGE & TOLERANCE OF 10%

FACEBOOK CONNECT1		DOCUMENT NUMBER: 00	
TITLE: HDMI LEVEL SHIFTER		LIFE- 3	SHEET 11OF 18

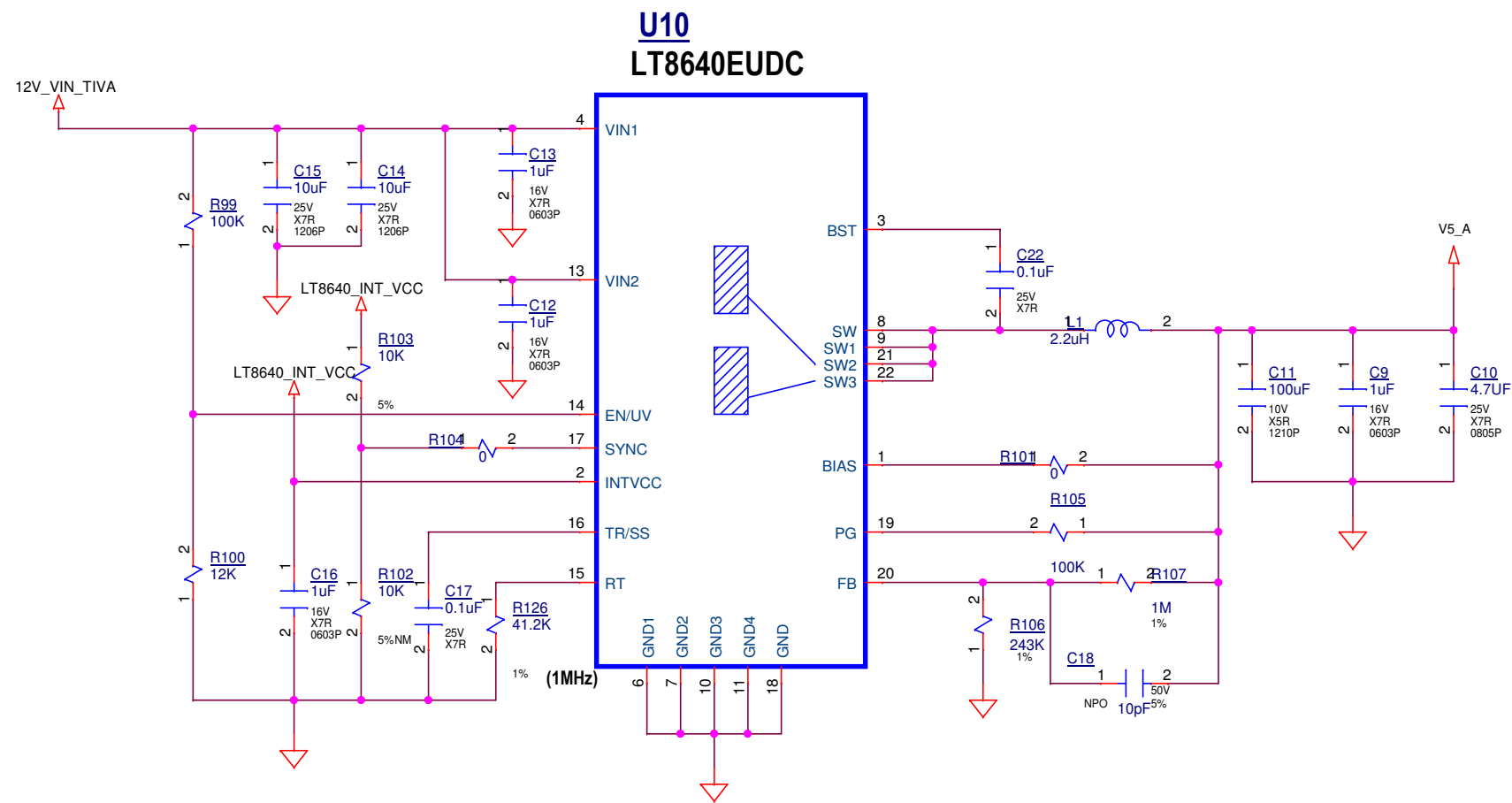

U10
LT8640EUDC

UNLESS OTHERWISE SPECIFIED:
RESISTORS ARE 0402 PACKAGE, POWER RATING < 0.5W & TOLERANCE > 1%
CAPACITORS ARE 0402 PACKAGE & TOLERANCE OF 10%

FACEBOOK CONNECT1		DOCUMENT NUMBER: 00	
TITLE: 12V TO 5V DC DC CONVERTER		LIFE- 3	SHEET 12OF 18

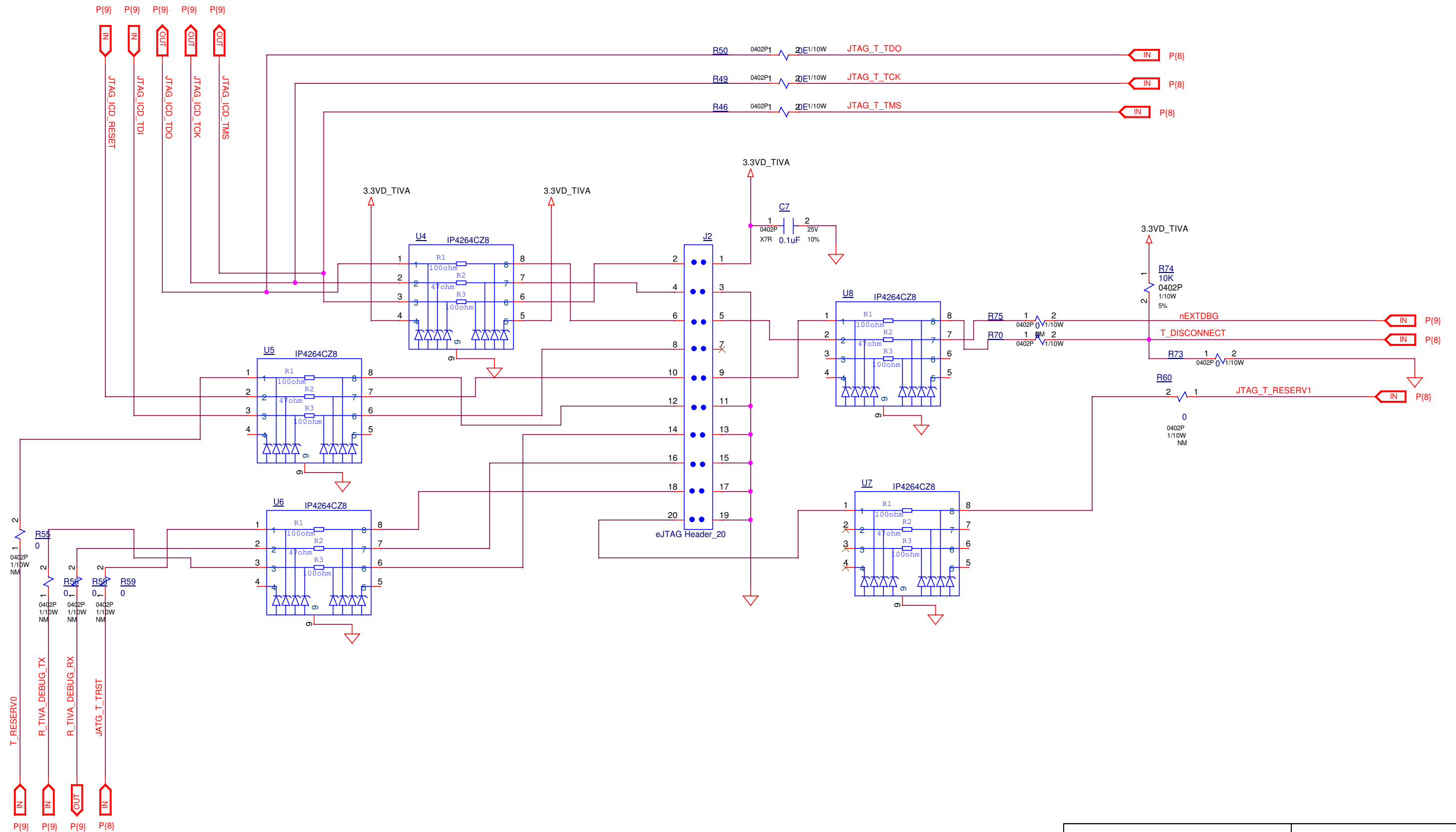

UNLESS OTHERWISE SPECIFIED:
 RESISTORS ARE 0402 PACKAGE, POWER RATING < 0.5W & TOLERANCE > 1%
 CAPACITORS ARE 0402 PACKAGE & TOLERANCE OF 10%

FACEBOOK CONNECT1		DOCUMENT NUMBER: 00	
TITLE: eJTAG CONNECTOR		LIFE- 3	SHEET 13 OF 18

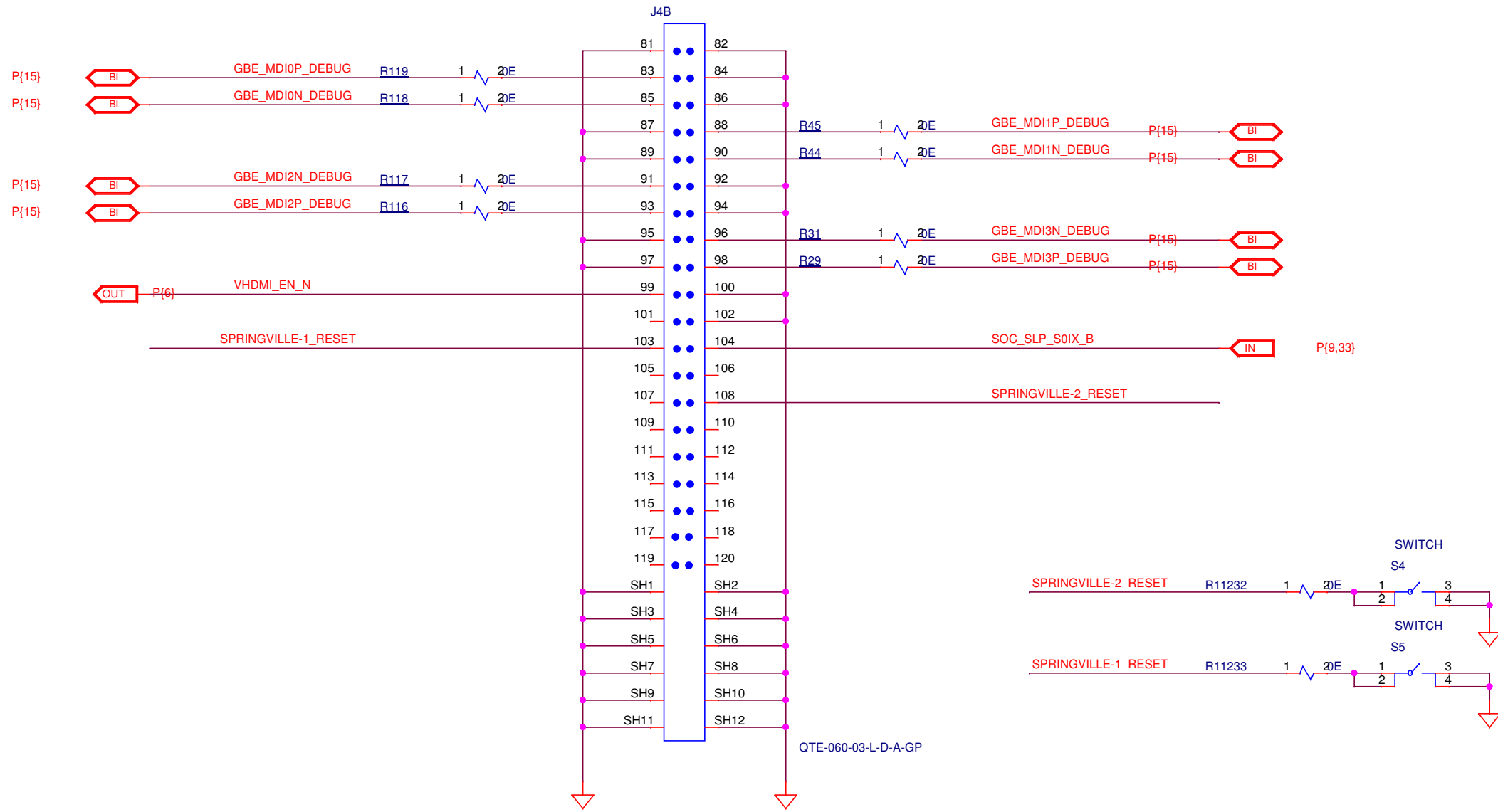

UNLESS OTHERWISE SPECIFIED:
 RESISTORS ARE 0402 PACKAGE, POWER RATING < 0.5W & TOLERANCE > 1%
 CAPACITORS ARE 0402 PACKAGE & TOLERANCE OF 10%

FACEBOOK CONNECT1		DOCUMENT NUMBER: 00
TITLE: DEBUG CONNECTOR 1	LIFE- 3	SHEET 14 OF 18

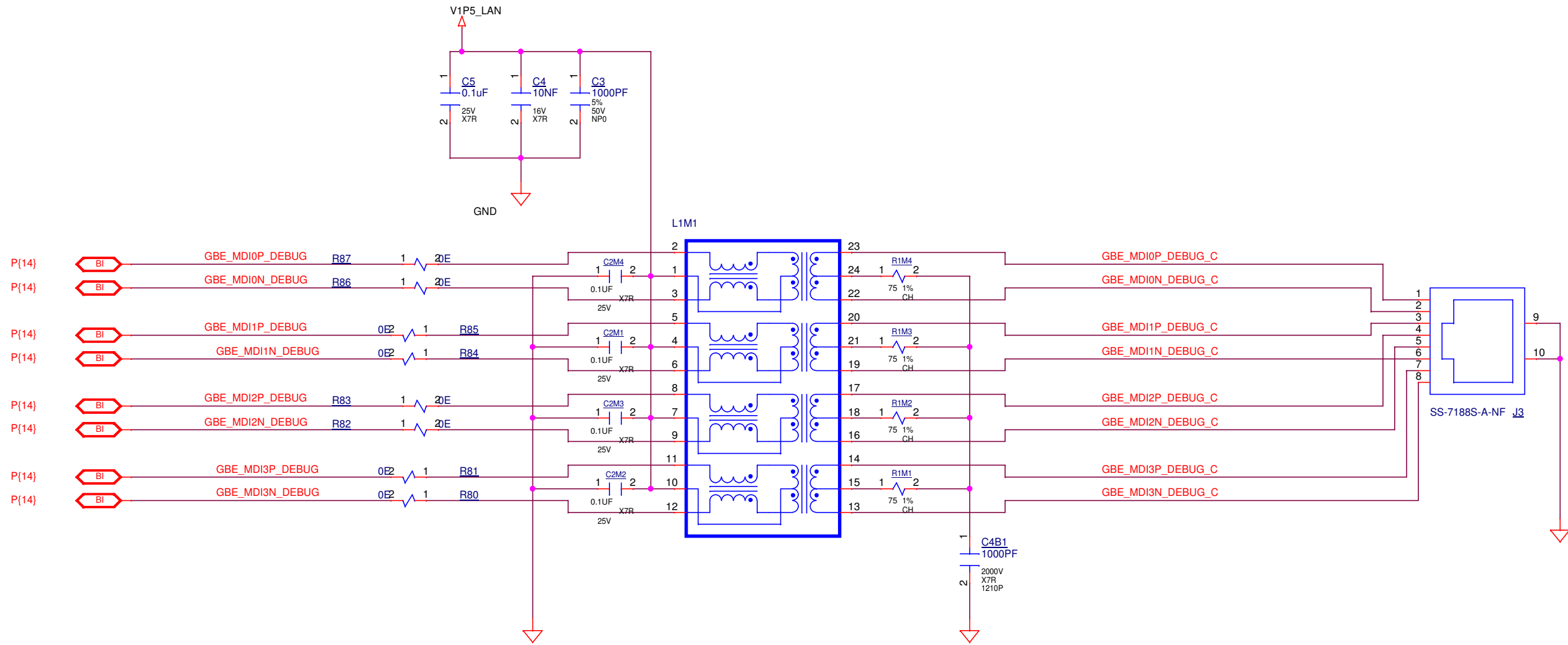

UNLESS OTHERWISE SPECIFIED:
 RESISTORS ARE 0402 PACKAGE, POWER RATING < 0.5W & TOLERANCE > 1%
 CAPACITORS ARE 0402 PACKAGE & TOLERANCE OF 10%

FACEBOOK CONNECT1		DOCUMENT NUMBER: 00	
TITLE: ETHERNET		LIFE- 3	SHEET 15 OF 18

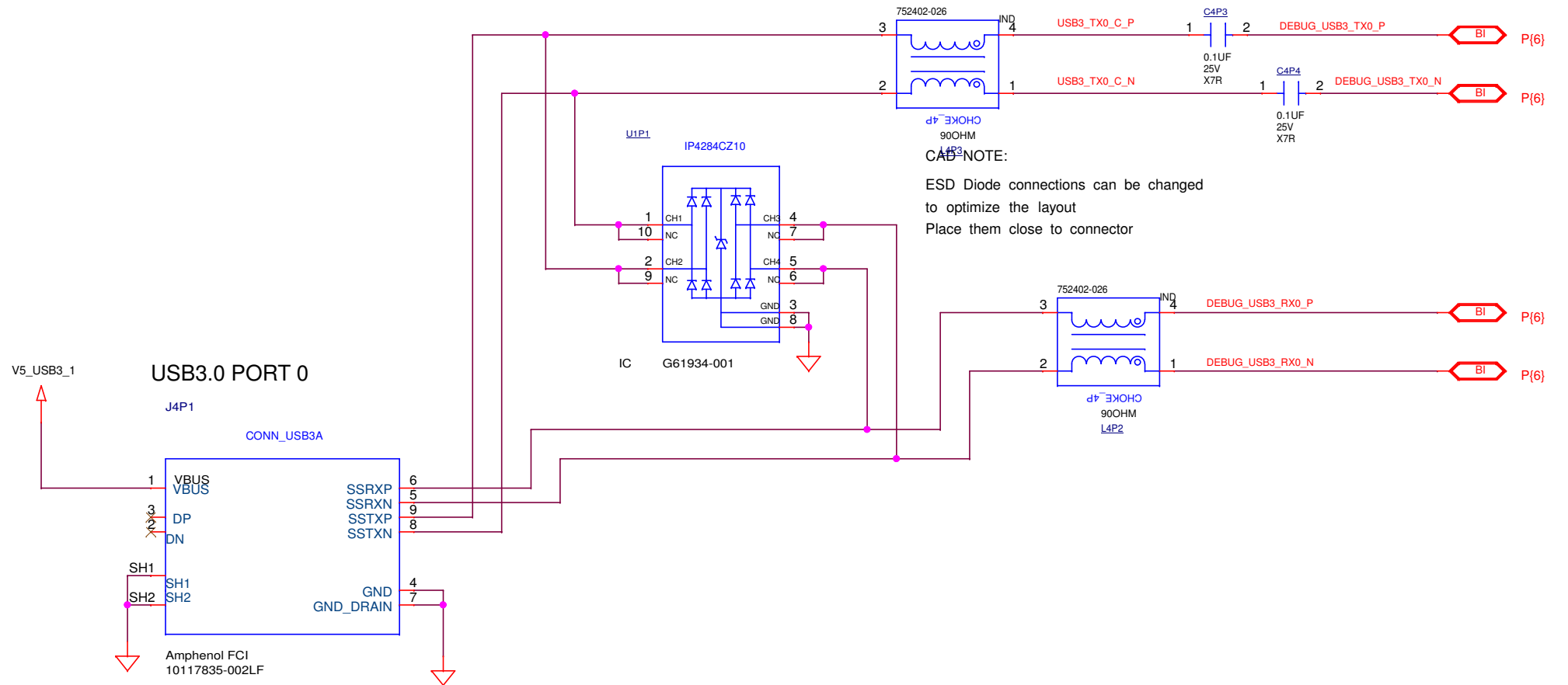
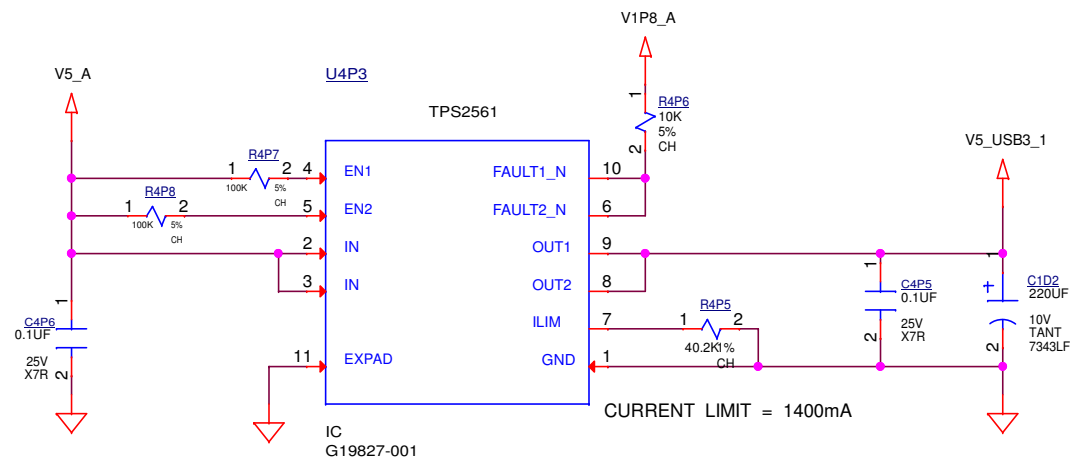

UNLESS OTHERWISE SPECIFIED:
 RESISTORS ARE 0402 PACKAGE, POWER RATING < 0.5W & TOLERANCE > 1%
 CAPACITORS ARE 0402 PACKAGE & TOLERANCE OF 10%

FACEBOOK CONNECT1		DOCUMENT NUMBER: 00
TITLE: HDMI SMBUS CONTROL	LIFE- 3	SHEET 16OF 18

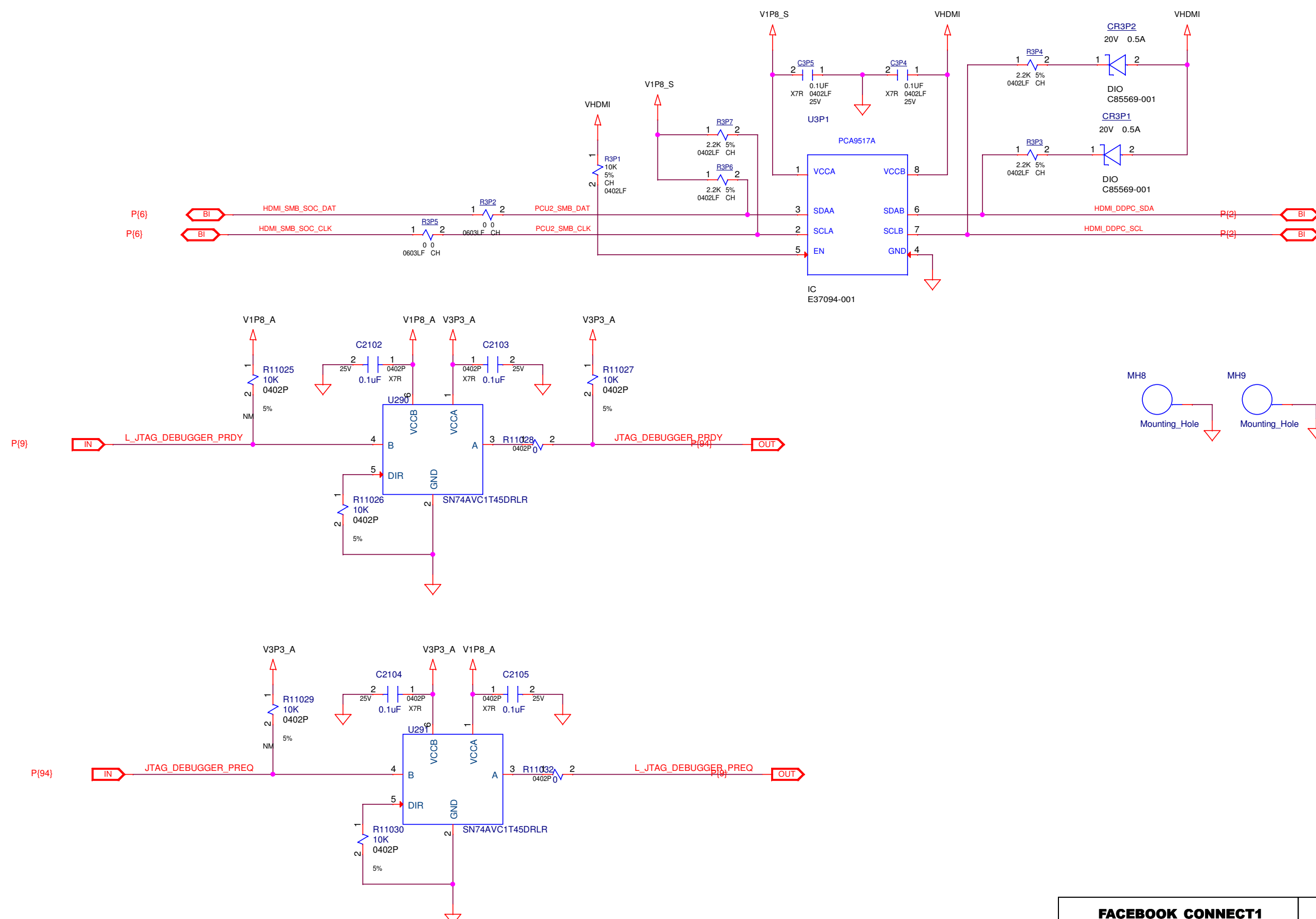

UNLESS OTHERWISE SPECIFIED:
 RESISTORS ARE 0402 PACKAGE, POWER RATING < 0.5W & TOLERANCE > 1%
 CAPACITORS ARE 0402 PACKAGE & TOLERANCE OF 10%

FACEBOOK CONNECT1		DOCUMENT NUMBER: 00	
TITLE: HDMI SMBUS CONTROL		LIFE- 3	SHEET 17OF 18

D

C

B

A

D

C

B

A

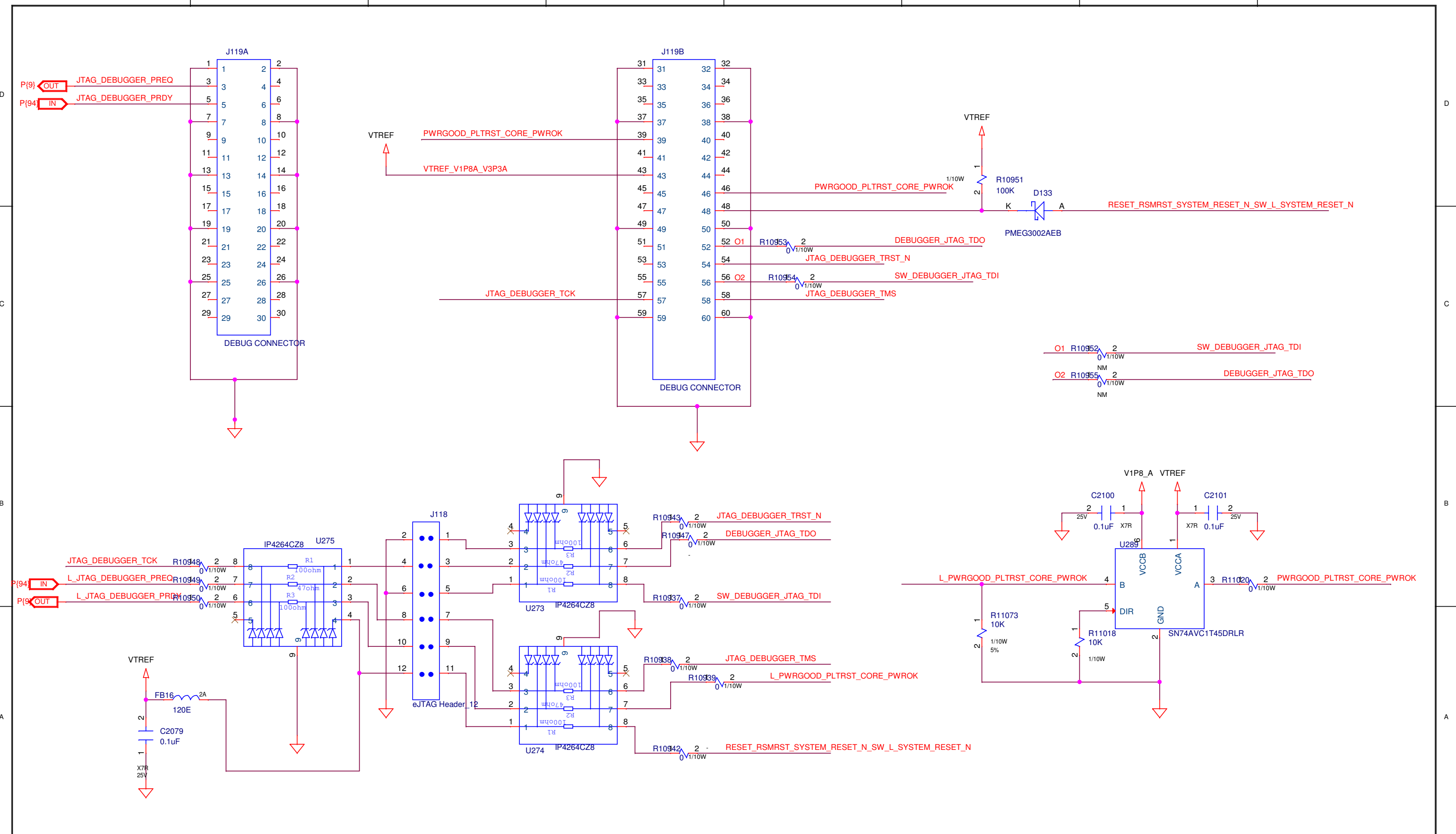

UNLESS OTHERWISE SPECIFIED:
 RESISTORS ARE 0402 PACKAGE, POWER RATING < 0.5W & TOLERANCE > 1%
 CAPACITORS ARE 0402 PACKAGE & TOLERANCE OF 10%

FACEBOOK CONNECT1		DOCUMENT NUMBER: 00	
TITLE: INTEL DEBUGGER		LIFE- 3	SHEET 18 OF 18