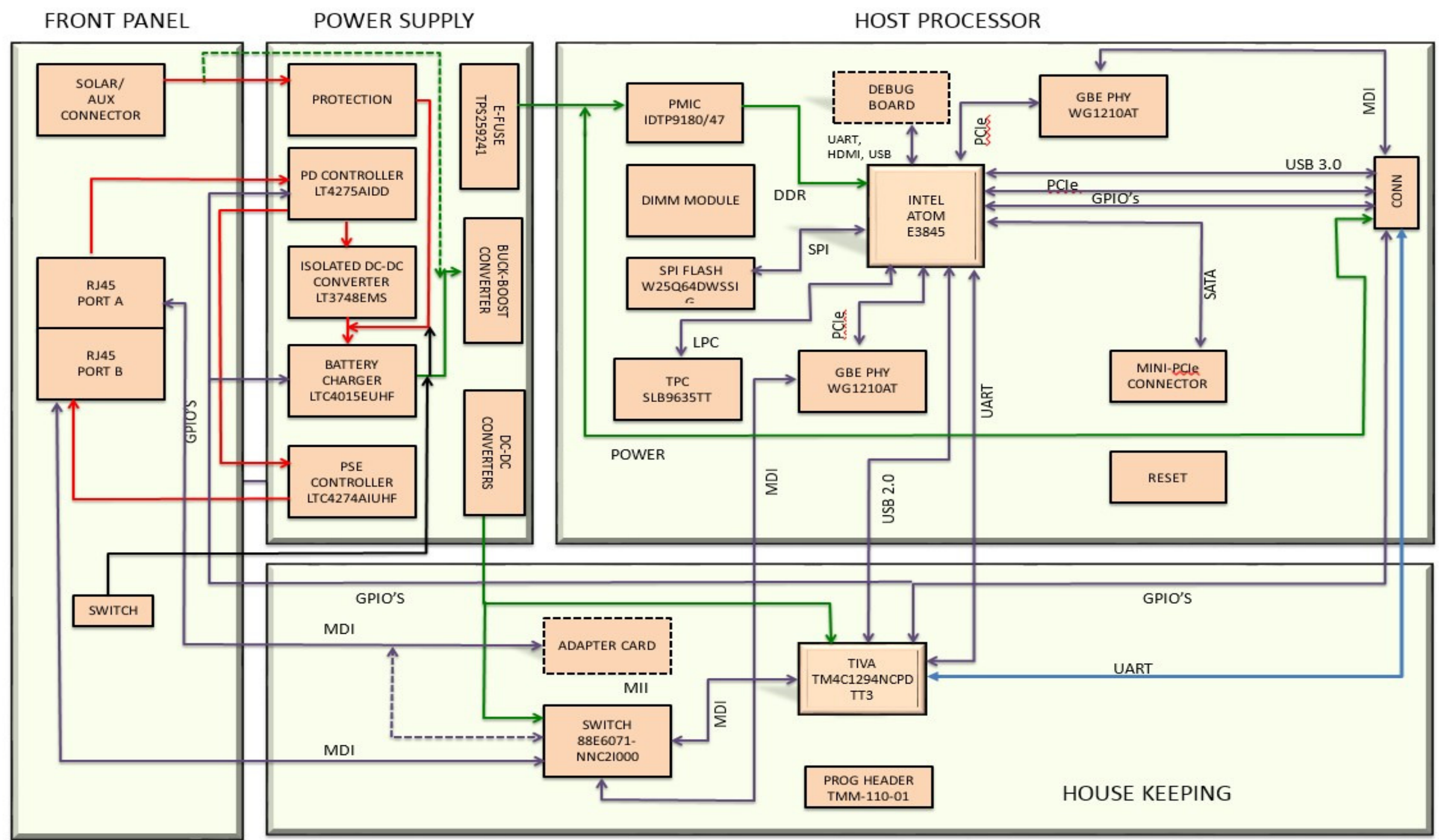


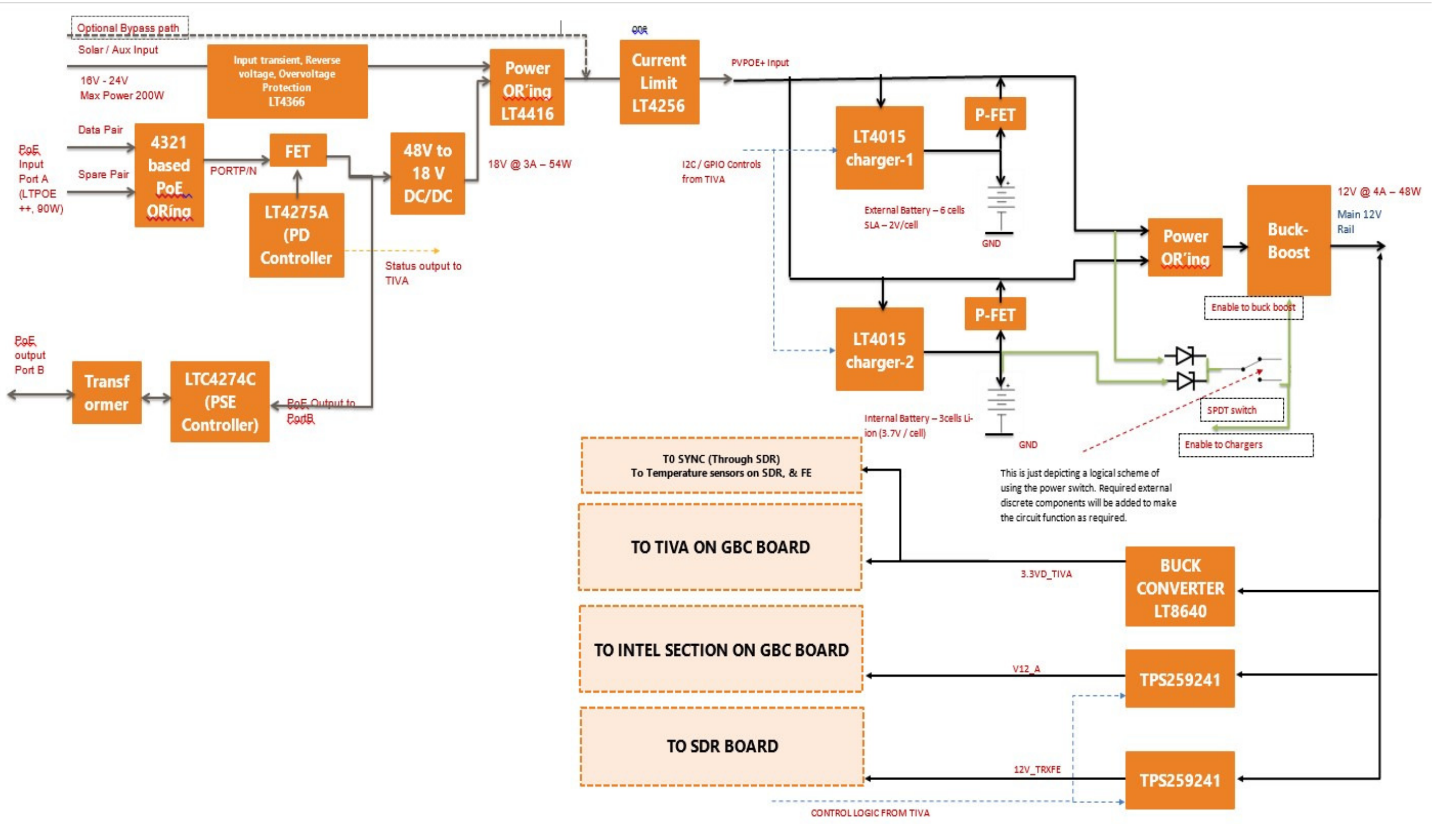
# TABLE OF CONTENTS

SHEET NUMBER	SHEET NAME	SHEET NUMBER	SHEET NAME
1	INDEX PAGE	56	DC-DC CONVERTER
2	BASE BAND BOARD BLOCK DIAGRAM	57	ETHERNET SWITCH
3	POWER BLOCK DIAGRAM	58	ETHERNET MUX/DEMUX
4	RESET BLOCK DIAGRAM	59	TIVA POWER
5	GBC ETHERNET BLOCK DIAGRAM	60	TIVA ETHERNET
6	GBC I2C TREE BLOCK DIAGRAM	61	TIVA IO'S
7	SYSTEM GPIO BLOCK DIAGRAM	62	TIVA GPIO
8	GBC USB BLOCK DIAGRAM	63	TIVA GPIO1
9	E3845: DDR CHANNEL A	64	TIVA GPIO2
10	E3845: DDR CHANNEL B	65	I2C AND SMB MUX/DEMUX
11	E3845: DISPLAY INTERFACES	66	BLANK
12	E3845: I/O INTERFACES	67	IO EXPANDER
13	E3845: CLOCK SPI POWER JTAG	68	RESET
14	E3845: POWER GROUND	69	DEBUG CONNECTOR
15	E3845: POWER	70	TEMP SENSORS
16	E3845: USB AND GPIO INTERFACE	71	TEMP SENSORS1
17	E3845: POWER	72	SOC ISOLATION
18	E3845: POWER GROUND	73	RADIO_ISOLATION
19	E3845: DDR 3P3 SMBUS CONTROL	74	SYNC CONNECTOR AND TIVA JTAG
20	DDR DIMMO CH A 1 OF 2	75	SDR CARD PWR
21	DDR DIMMO CH A 2 OF 2	76	BOARD TO BOARD CONNECTOR
22	DDR DIMMO CH B 1 OF 2	77	RESET SWITCH
23	DDR DIMMO CHB 2 OF 2	78	SOC LEVEL TRANSLATOR
24	SPI FLASH	79	MTG HOLES
25	MSATA	80	ETHSW_2.5VPWR
26	GBE PHY- 1	81	ETHSW_EPROM
27	ETHERNET- 1	82	RADIO ISOLATION
28	GBE PHY- 2	83	TIVA SOC ISOLATION
29	ETHERNET- 2	84	SOC TRXFE ISOLATION
30	PMIC	85	USB SWITCH
31	PMIC	86	SOC PCIE SWITCH
32	PMIC	87	DEBUG CONNECTOR1
33	PMIC	88	LT4231_LACID
34	PMIC	89	LT4231_LION
35	PMIC	90	TEST_POINTS
36	PMIC	91	TEST_POINTS
37	PMIC	92	JTAG INTERFACE
38	STRAPING	93	TIVA JTAG
39	POWER	94	JTAG
40	POWER	95	JTAG_CONTD
41	TPM	96	BUZZER
42	SOLAR AVX		
43	PORT A RJ45		
44	POE BRIDGE		
45	POE PD		
46	PORTB RJ45		
47	POE PSE		
48	PSE I2C ISO		
49	48VTO 18V ISOLATED CONVERTER		
50	POWER ORING AND PROTECTION		
51	LEAD ACID BATTERY CHARGER		
52	LITHIUM ION BATTERY CHARGER		
53	POWER ORING		
54	BUCK BOOST CONVERTER		
55	POWER SWITCH		

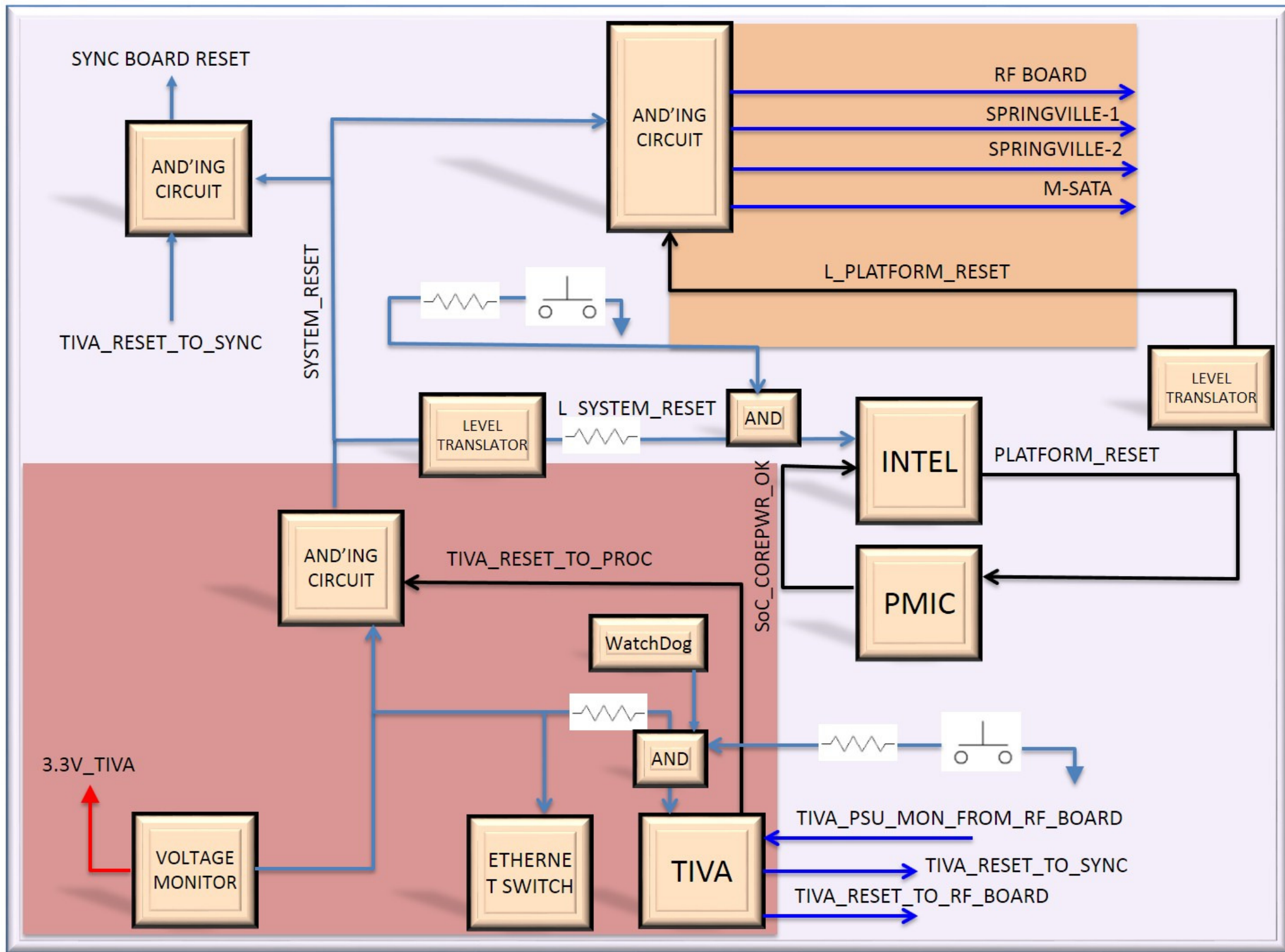
REVISION HISTORY			
DATE	VERSION	UPDATED BY	REMARKS
26 JAN 2016	1.00		REV A RELEASE
14 JUNE 2016	LIFE-2		LIFE-2 RELEASE
30 NOV 2016	LIFE-3		LIFE-3 RELEASE



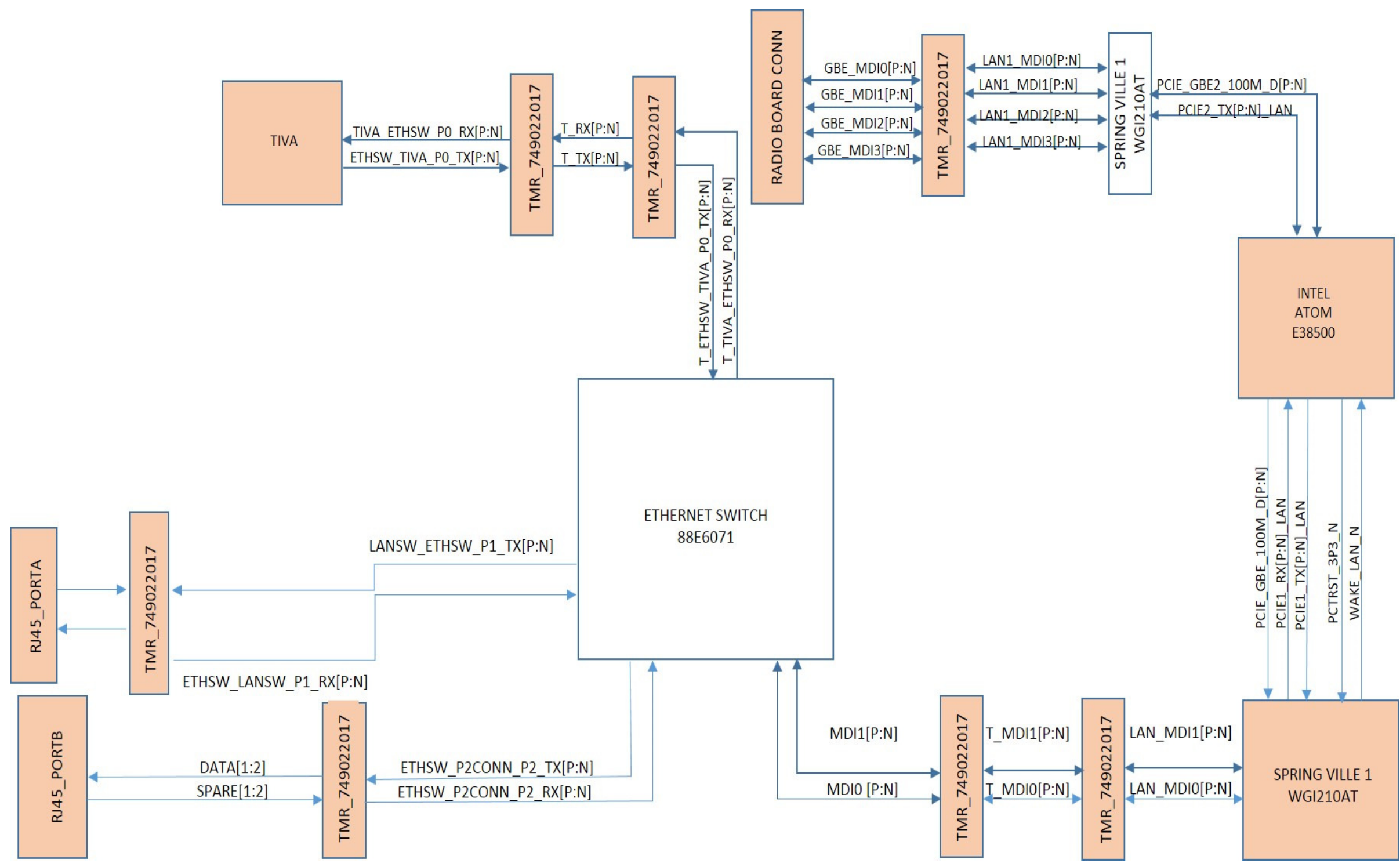
GBC BLOCK DIAGRAM



SYSTEM POWER INPUT SCHEME



RESET TREE



### GBC ETHERNET INTERFACES

8 7 6 5 4 3 2 1

D

C

B

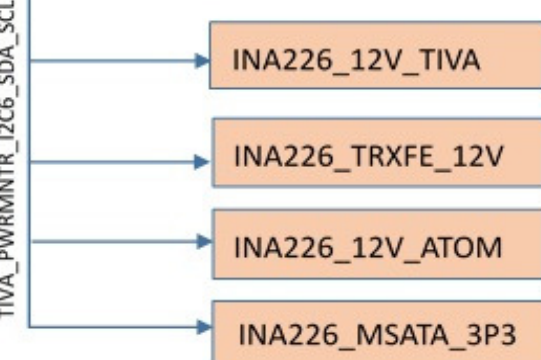
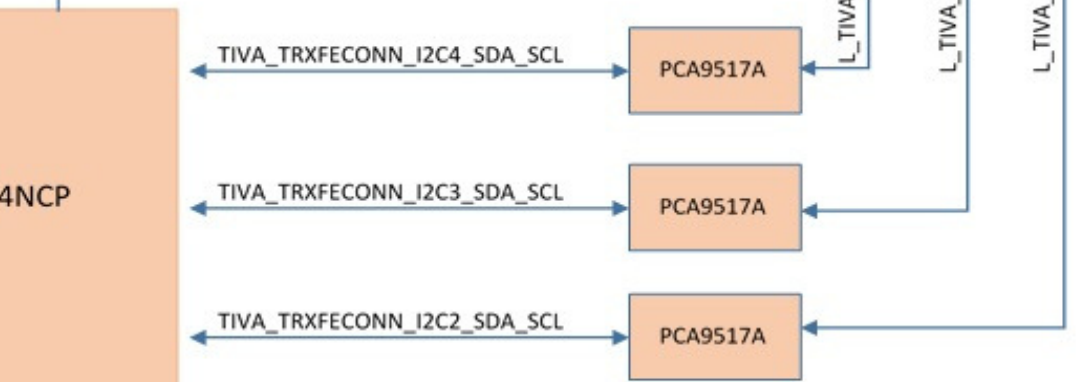
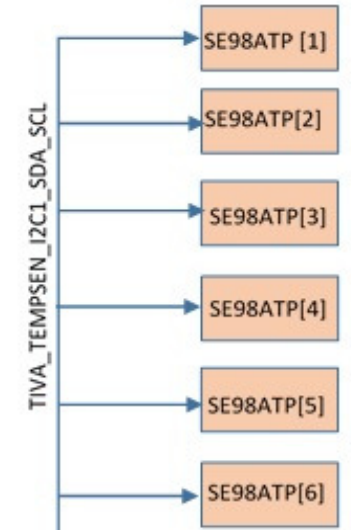
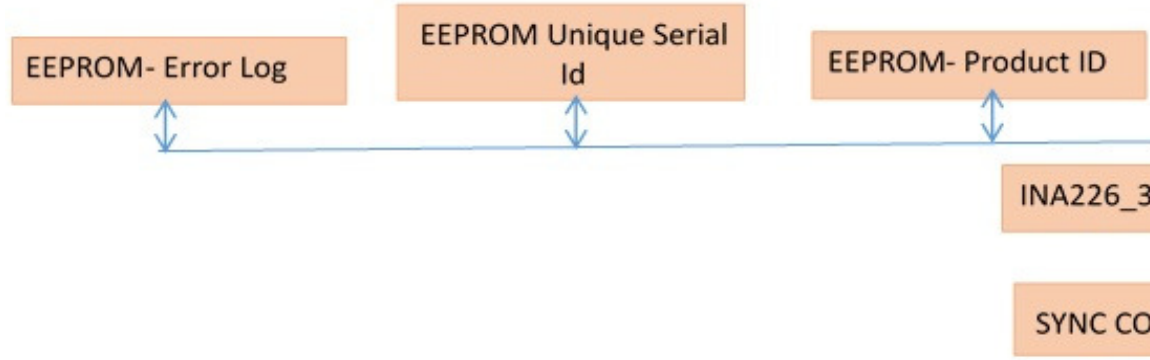
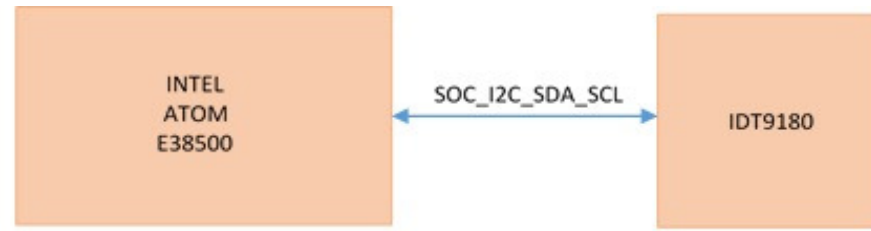
A

D

C

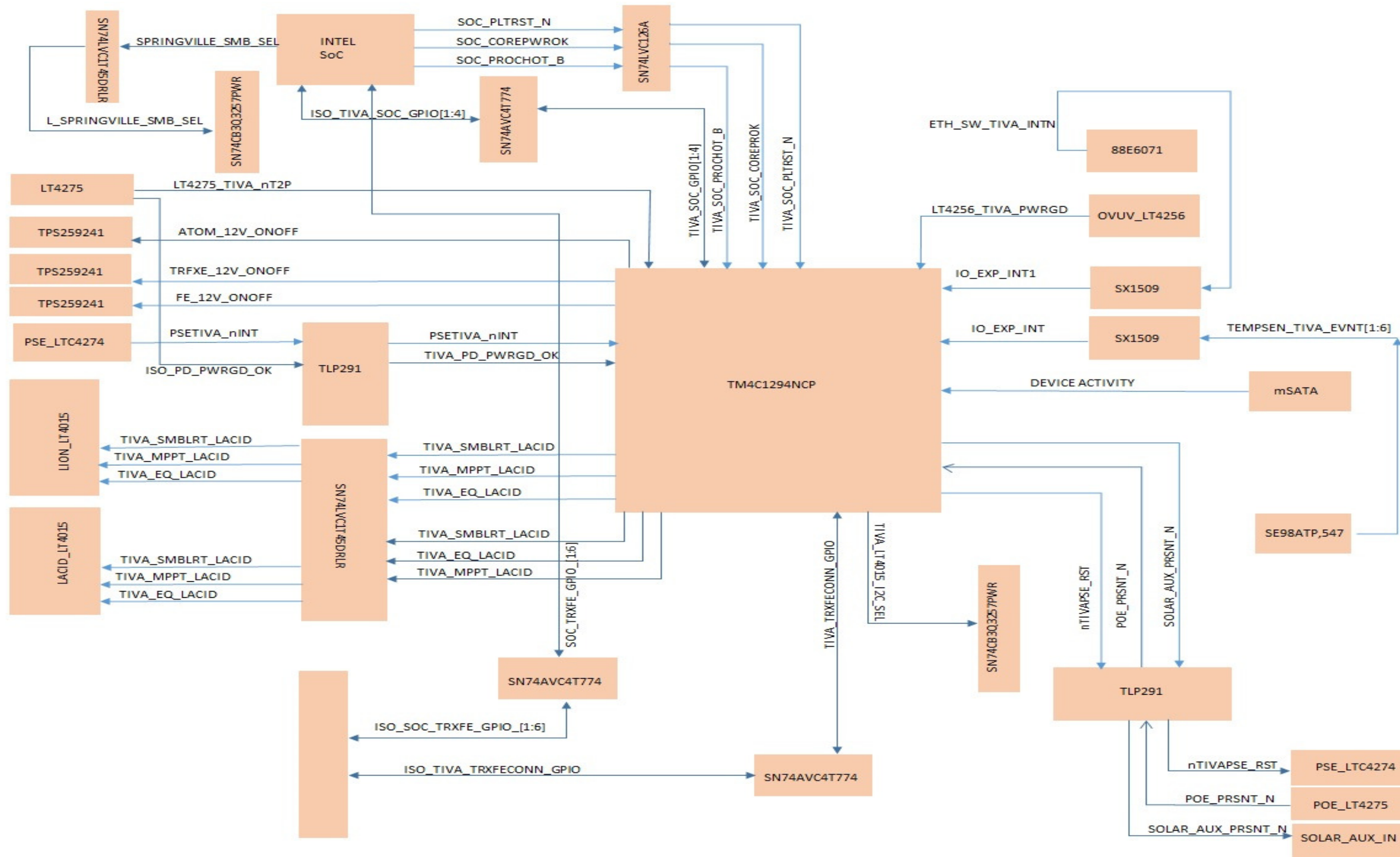
B

A



### GBC I2C TREE

8 7 6 5 4 3 2 1



CONTROL SIGNALS FROM TIVA

<b>OpenCellular</b>	DOCUMENT NUMBER: 232-000036	
	TITLE: SYSTEM GPIO BLOCK DIAGRAM	LIFE 3 SHEET 7 OF 96

RADIO\_BOARD\_CONN  
HDAF-11-18-S-13-2

DEBUG CONNECTOR

INTEL  
ATOM

TM4C1294NCPDT  
TIVA MUC

USB\_D[P:N]0  
USB3\_RX0\_[P:N]  
USB3\_TX0\_[P:N]

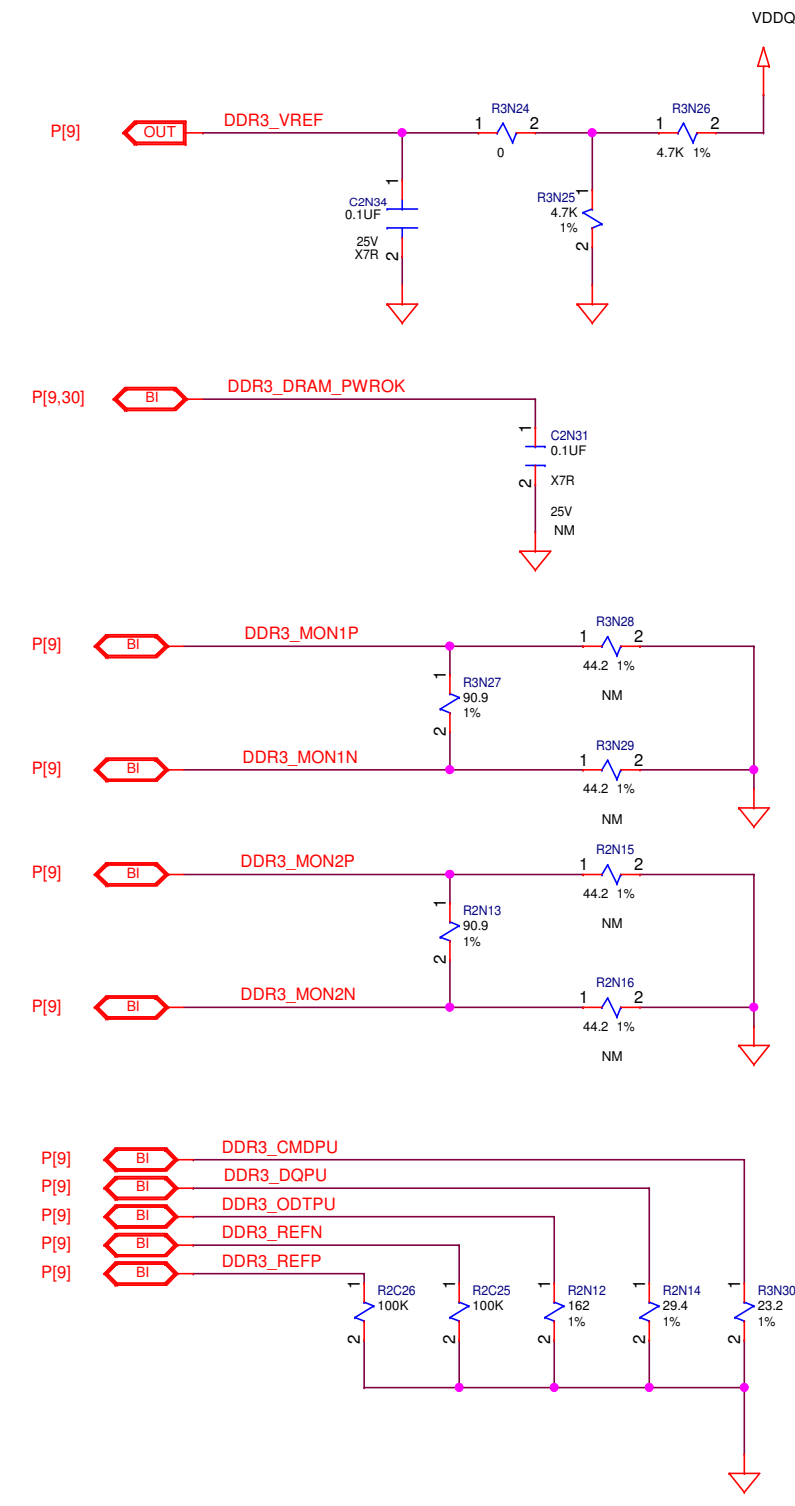
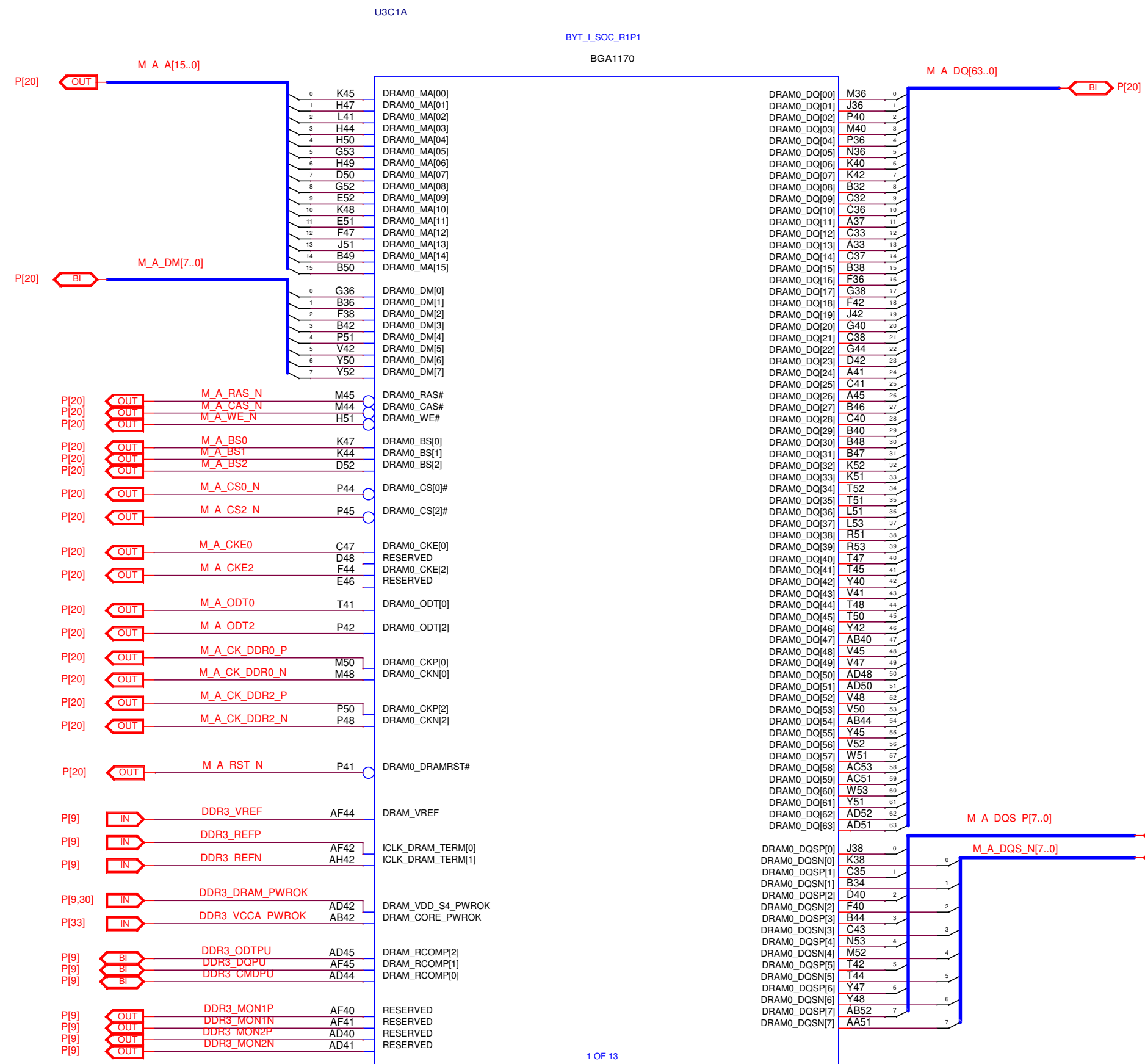
USB\_D[P:N]1  
USB\_D[P:N]2

USB\_D[P:N]3

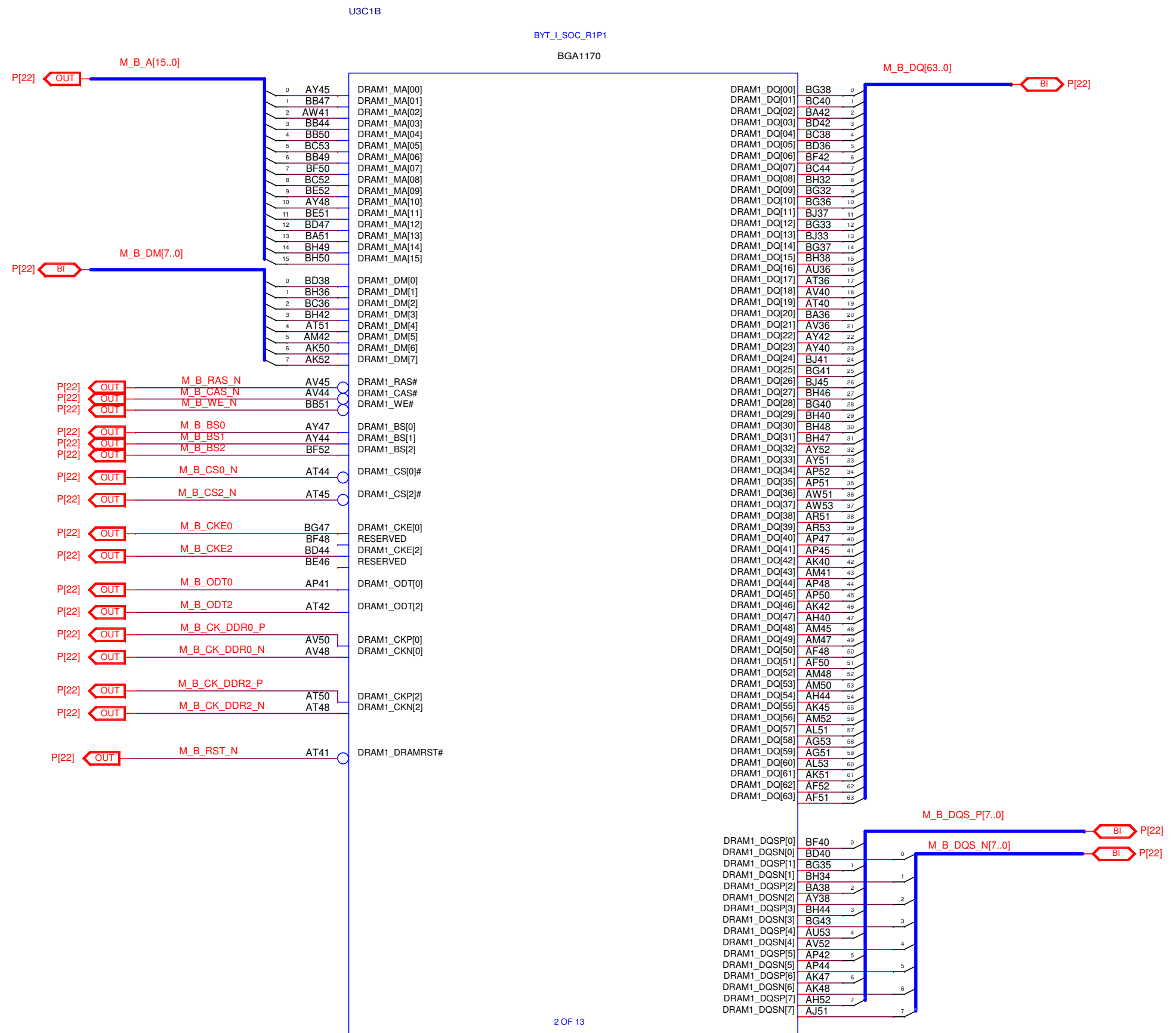
USB TREE



UNLESS OTHERWISE SPECIFIED:  
RESISTORS ARE 0402 PACKAGE, POWER RATING < 0.5W & TOLERANCE > 1%  
CAPACITORS ARE 0402 PACKAGE & TOLERANCE OF 10%

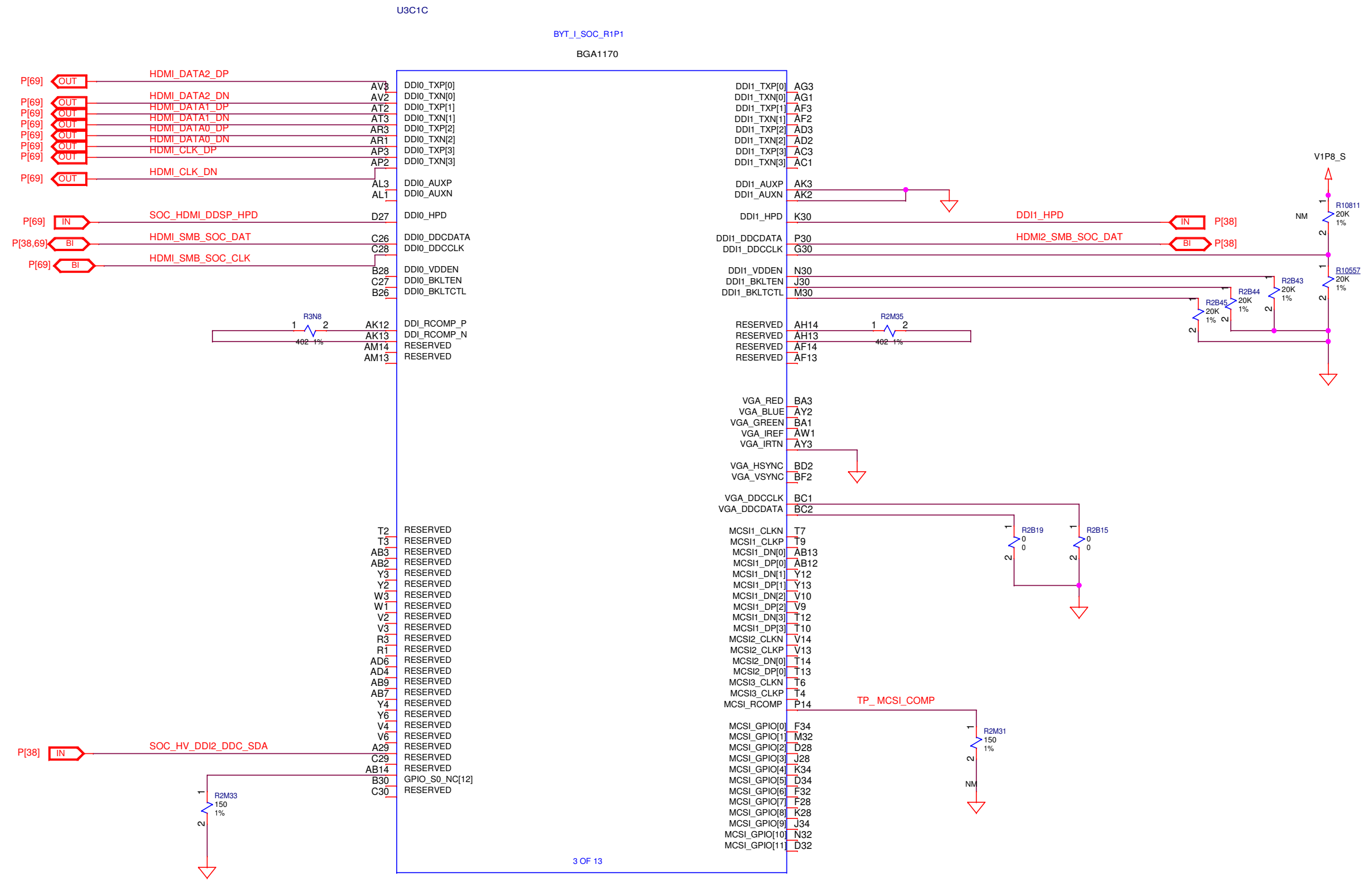


8 7 6 5 4 3 2 1



8 7 6 5 4 3 2 1

UNLESS OTHERWISE SPECIFIED:  
RESISTORS ARE 0402 PACKAGE, POWER RATING < 0.5W & TOLERANCE > 1%  
CAPACITORS ARE 0402 PACKAGE & TOLERANCE OF 10%

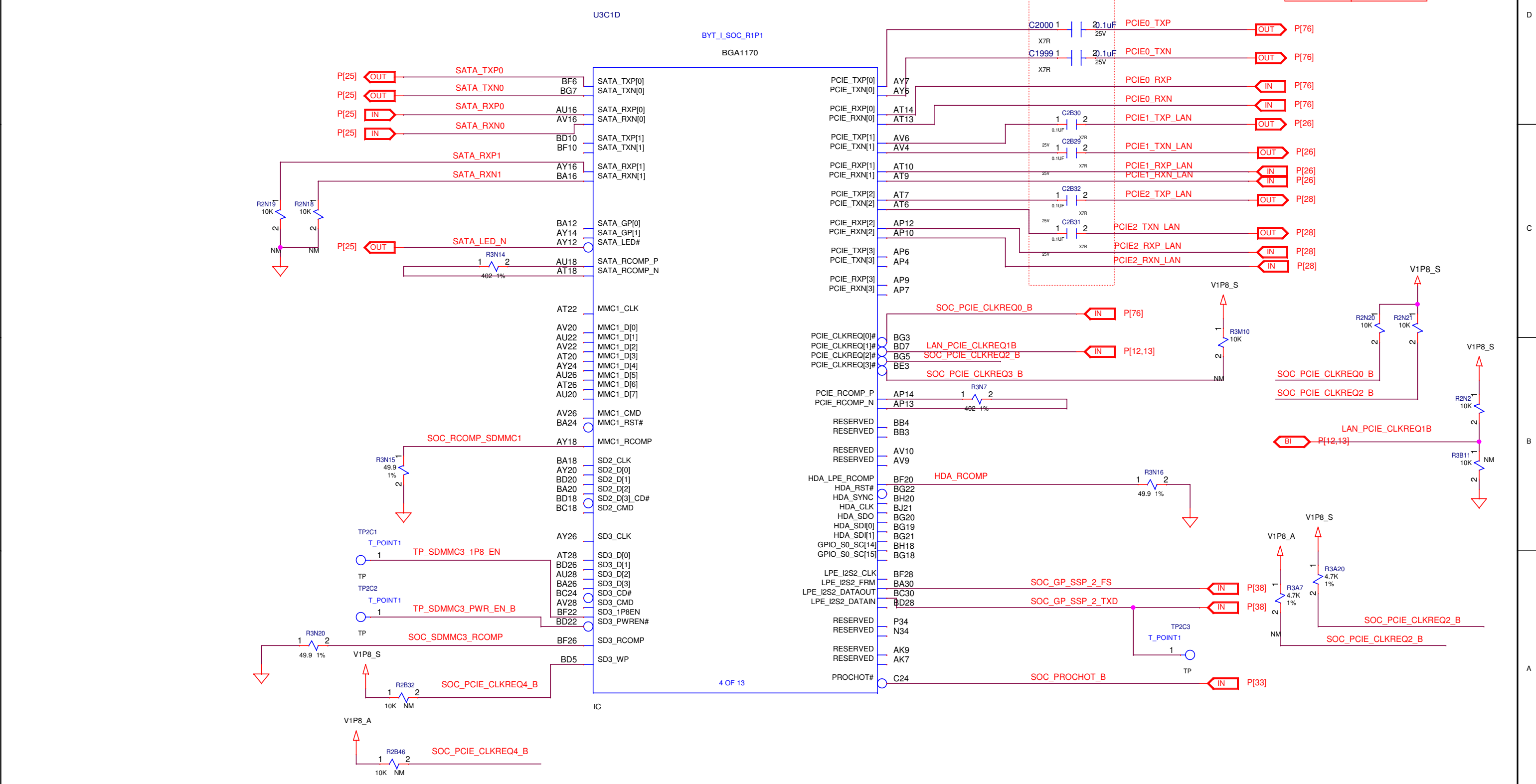


3 OF 13

UNLESS OTHERWISE SPECIFIED:  
RESISTORS ARE 0402 PACKAGE, POWER RATING < 0.5W & TOLERANCE > 1%  
CAPACITORS ARE 0402 PACKAGE & TOLERANCE OF 10%

PCIE-0	GEN2
PCIE-1 PCIE-2	GEN1 GEN1

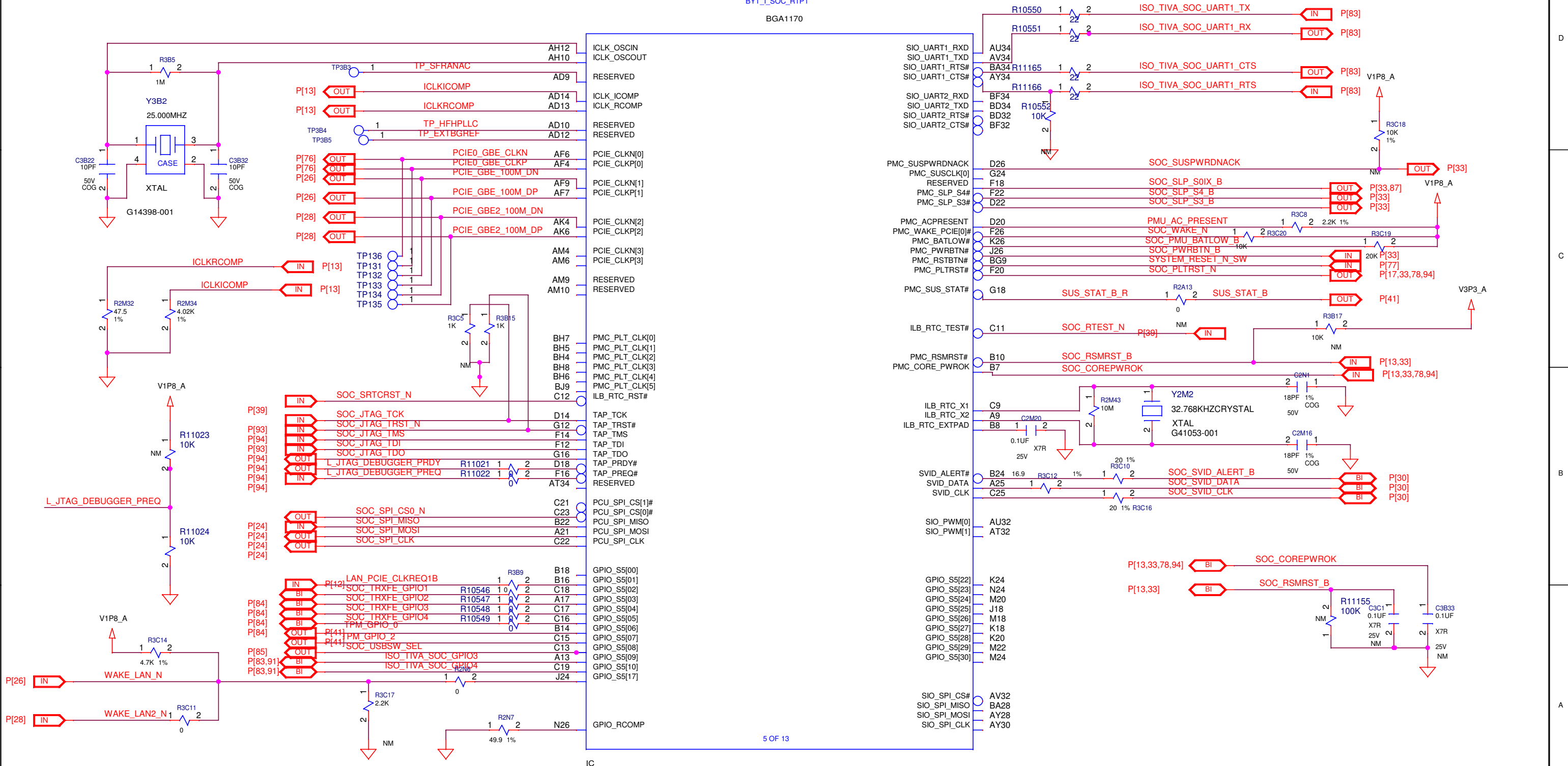
CAD NOTE: ALL THE CAPACITORS SHOULD BE PLACED NEAR U3C1



UNLESS OTHERWISE SPECIFIED:  
RESISTORS ARE 0402 PACKAGE, POWER RATING < 0.5W & TOLERANCE > 1%  
CAPACITORS ARE 0402 PACKAGE & TOLERANCE OF 10%

U3C1E

BYT\_I\_SOC\_R1P1  
BGA1170



5 OF 13

8 7 6 5 4 3 2 1

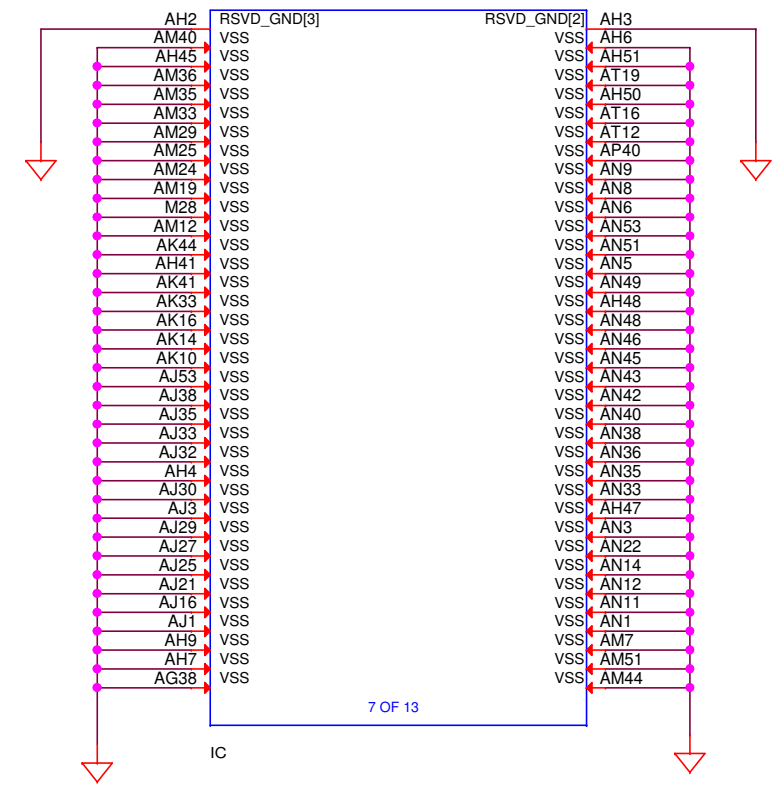
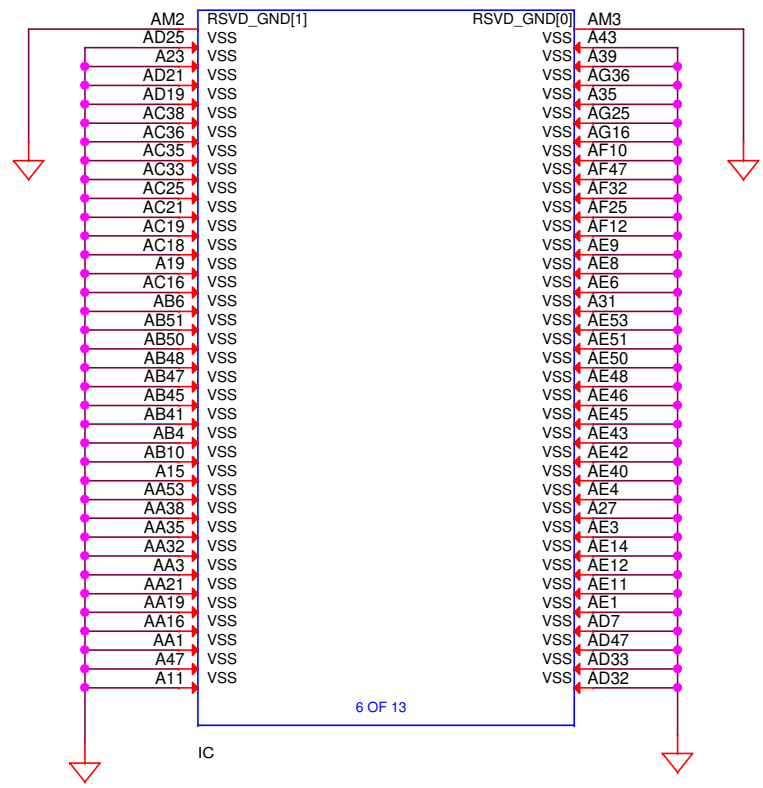
U3C1G

BYT\_L\_SOC\_R1P1  
BGA1170

SECTION 2.31 OF E3800 DATA SHEET SUGGESTS TO CONNECT RSVD\_GND PIN TO COMMON GND PIN.

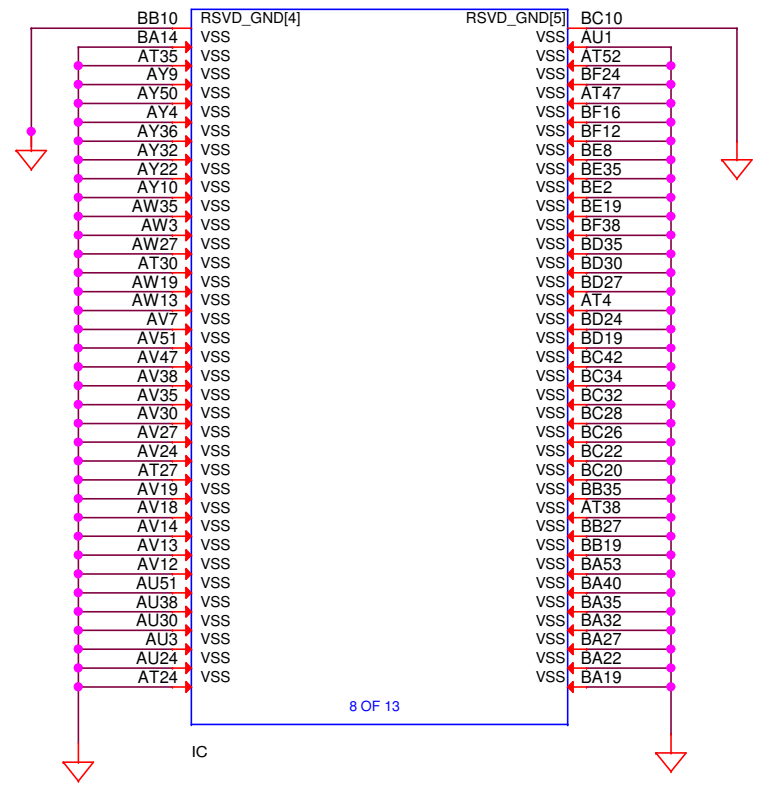
U3C1I

BYT\_L\_SOC\_R1P1  
BGA1170



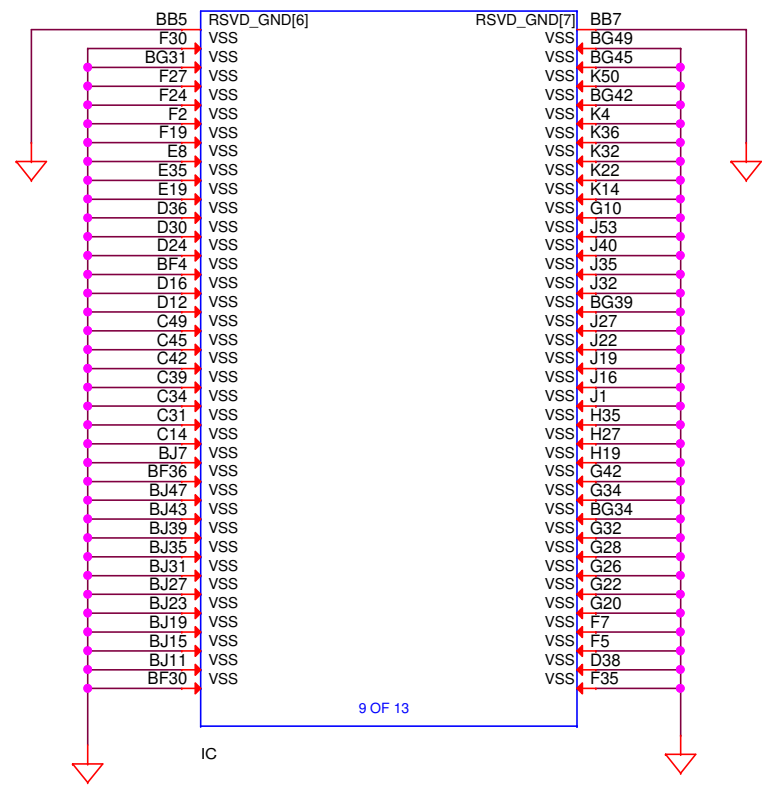
U3C1F

BYT\_L\_SOC\_R1P1  
BGA1170



U3C1H

BYT\_L\_SOC\_R1P1  
BGA1170



8 7 6 5 4 3 2 1

D

D

C

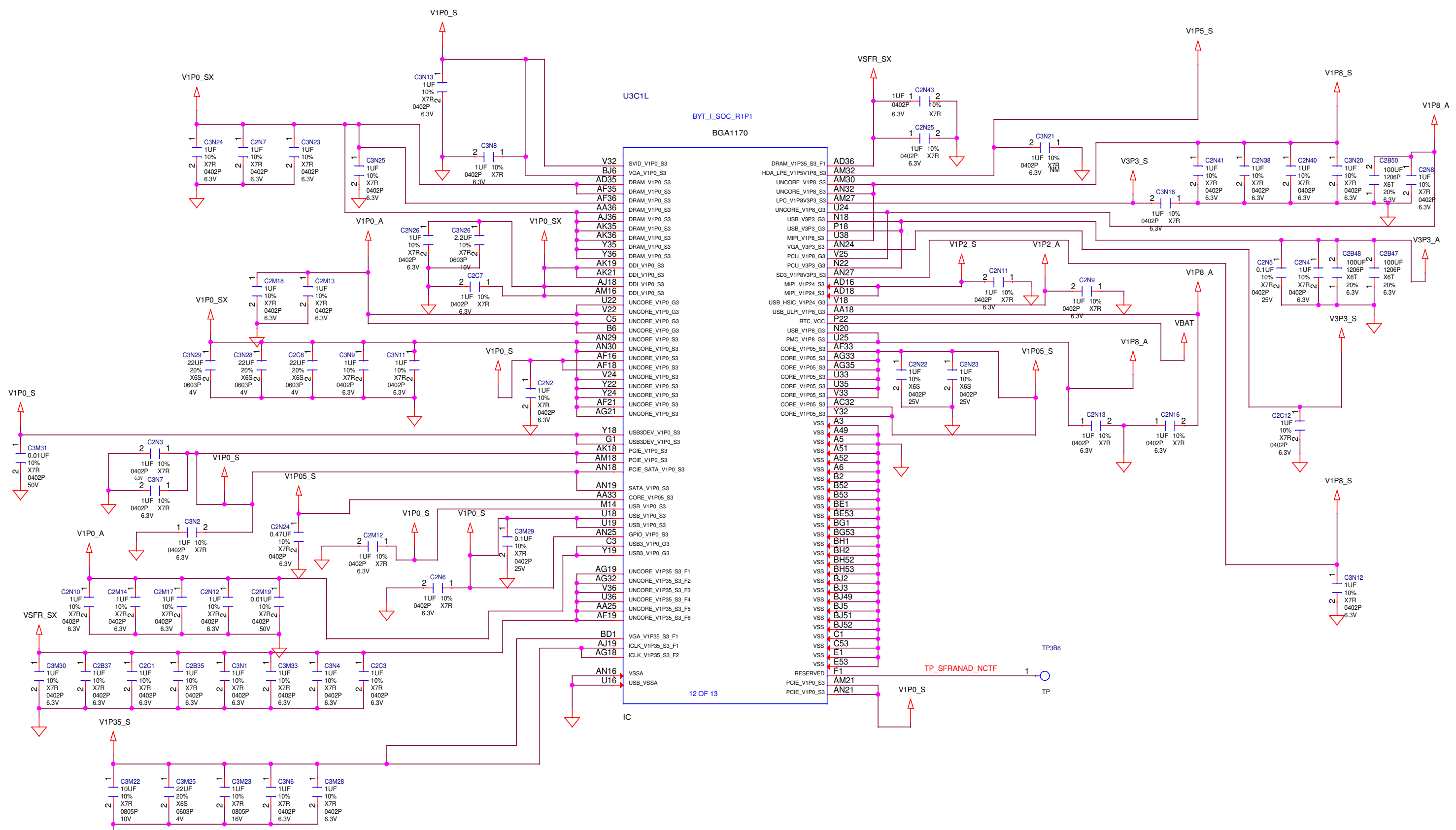
C

B

B

A

A



U3C1L  
BYT\_I\_SOC\_R1P1  
BGA1170

- V32 SVID\_V1P0\_S3
- BJ6 VGA\_V1P0\_S3
- AD35 DRAM\_V1P0\_S3
- AF35 UNCORE\_V1P8\_S3
- AF36 DRAM\_V1P0\_S3
- AA36 DRAM\_V1P0\_S3
- AJ36 DRAM\_V1P0\_S3
- AK35 DRAM\_V1P0\_S3
- AK36 DRAM\_V1P0\_S3
- Y35 DRAM\_V1P0\_S3
- Y36 DRAM\_V1P0\_S3
- AK19 DDI\_V1P0\_S3
- AK21 DDI\_V1P0\_S3
- AJ18 DDI\_V1P0\_S3
- AM16 DDI\_V1P0\_S3
- U22 UNCORE\_V1P0\_G3
- V22 UNCORE\_V1P0\_G3
- C5 UNCORE\_V1P0\_G3
- B6 UNCORE\_V1P0\_G3
- AN29 UNCORE\_V1P0\_G3
- AN30 UNCORE\_V1P0\_S3
- AF16 UNCORE\_V1P0\_S3
- AF18 UNCORE\_V1P0\_S3
- V24 UNCORE\_V1P0\_S3
- Y22 UNCORE\_V1P0\_S3
- Y24 UNCORE\_V1P0\_S3
- AF21 UNCORE\_V1P0\_S3
- AG21 UNCORE\_V1P0\_S3
- Y18 USB3DEV\_V1P0\_S3
- G1 USB3DEV\_V1P0\_S3
- AK18 PCIE\_V1P0\_S3
- AM18 PCIE\_V1P0\_S3
- AN18 PCIE\_SATA\_V1P0\_S3
- AN19 SATA\_V1P0\_S3
- AA33 CORE\_V1P05\_S3
- M14 USB\_V1P0\_S3
- U18 USB\_V1P0\_S3
- U19 USB\_V1P0\_S3
- AN25 GPIO\_V1P0\_S3
- C3 USB3\_V1P0\_G3
- Y19 USB3\_V1P0\_G3
- AG19 UNCORE\_V1P35\_S3\_F1
- AG32 UNCORE\_V1P35\_S3\_F2
- V36 UNCORE\_V1P35\_S3\_F3
- U36 UNCORE\_V1P35\_S3\_F4
- AA25 UNCORE\_V1P35\_S3\_F5
- AF19 UNCORE\_V1P35\_S3\_F6
- BD1 VGA\_V1P35\_S3\_F1
- AJ19 ICLK\_V1P35\_S3\_F1
- AG18 ICLK\_V1P35\_S3\_F2
- AN16 VSSA
- U16 USB\_VSSA

- DRAM\_V1P35\_S3\_F1 AD36
- HDA\_LPE\_V1P5V1P8\_S3 AM32
- UNCORE\_V1P8\_S3 AM30
- UNCORE\_V1P8\_S3 AN32
- LPC\_V1P8V3P3\_S3 AM27
- UNCORE\_V1P8\_G3 U24
- USB\_V3P3\_G3 N18
- USB\_V3P3\_G3 P18
- USB\_V3P3\_G3 U38
- VGA\_V3P3\_S3 AN24
- PCU\_V1P8\_G3 V25
- PCU\_V3P3\_G3 N22
- SD3\_V1P8V3P3\_S3 AN27
- MIPU\_V1P24\_S3 AD16
- MIPU\_V1P24\_S3 AD18
- USB\_HSIC\_V1P24\_G3 V18
- USB\_ULPI\_V1P8\_G3 AA18
- RTC\_VCC P22
- USB\_V1P8\_G3 N20
- PMC\_V1P8\_G3 U25
- CORE\_V1P05\_S3 AF33
- CORE\_V1P05\_S3 AG33
- CORE\_V1P05\_S3 AG35
- CORE\_V1P05\_S3 U33
- CORE\_V1P05\_S3 U35
- CORE\_V1P05\_S3 V33
- CORE\_V1P05\_S3 AC32
- CORE\_V1P05\_S3 Y32
- VSS A3
- VSS A49
- VSS A5
- VSS A51
- VSS A52
- VSS A6
- VSS B2
- VSS B52
- VSS B53
- VSS BE1
- VSS BE53
- VSS BG1
- VSS BG53
- VSS BH1
- VSS BH2
- VSS BH52
- VSS BH53
- VSS BJ2
- VSS BJ3
- VSS BJ49
- VSS BJ5
- VSS BJ51
- VSS BJ52
- VSS C1
- VSS C53
- VSS E1
- VSS E53
- RESERVED F1
- PCIE\_V1P0\_S3 AM21
- PCIE\_V1P0\_S3 AN21

UNLESS OTHERWISE SPECIFIED:  
 RESISTORS ARE 0402 PACKAGE, POWER RATING < 0.5W & TOLERANCE > 1%  
 CAPACITORS ARE 0402 PACKAGE & TOLERANCE OF 10%


U3C1K

BYT\_SOC\_R1P1

BGA1170

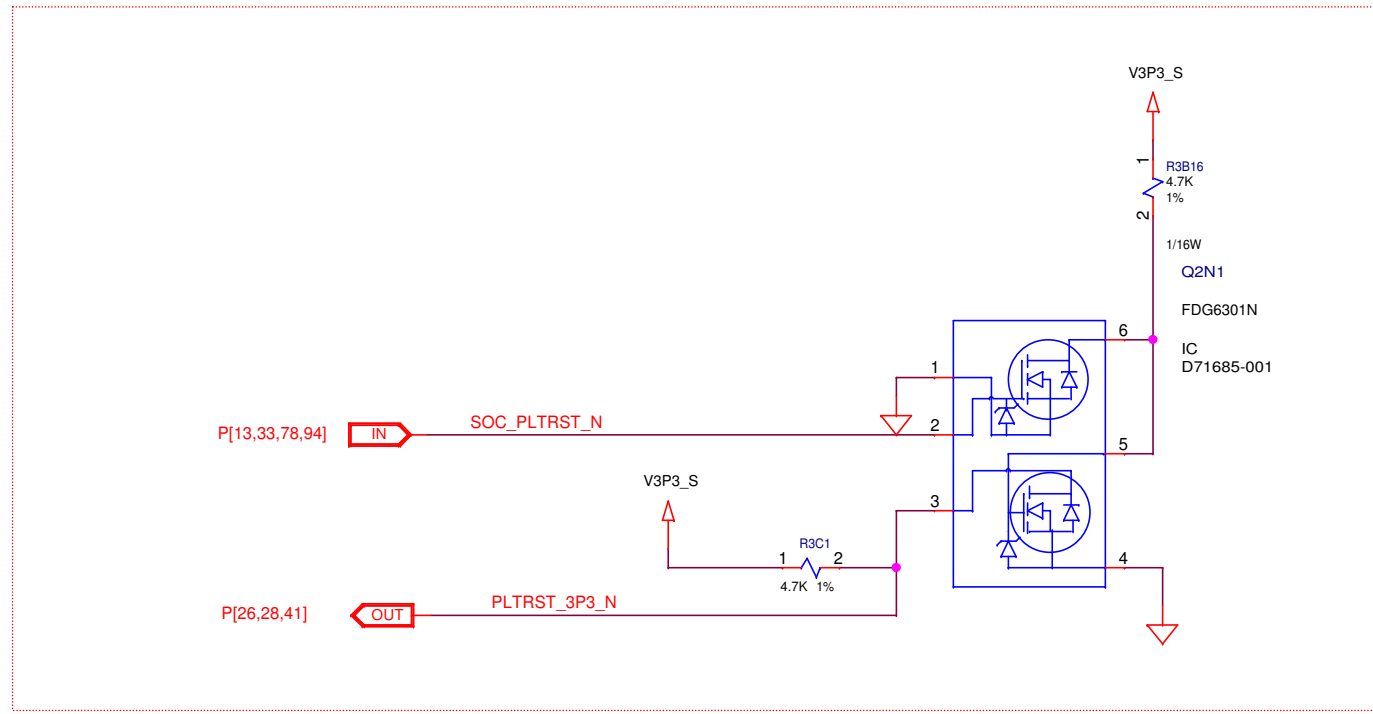
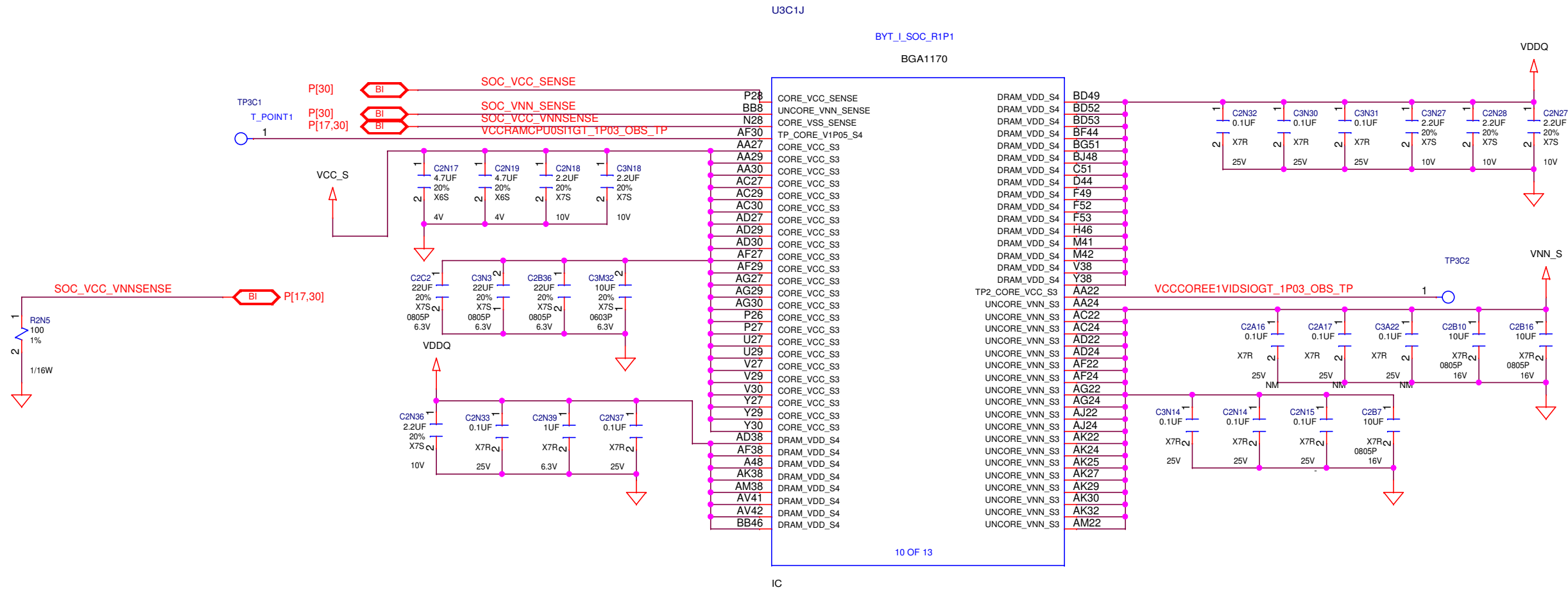


11 OF 13

 <b>OpenCellular</b>		DOCUMENT NUMBER: 232-000036	
TITLE: E3845 : USB AND GPIO INTERFACE		LIFE 3	SHEET 16 OF 96



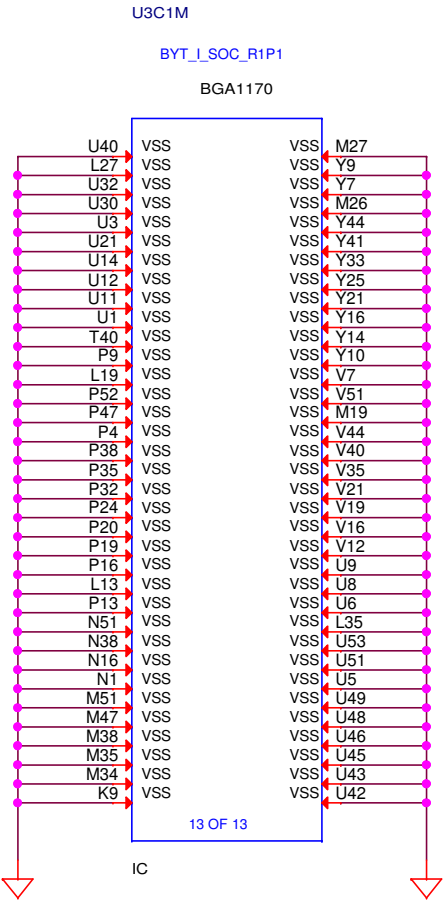
UNLESS OTHERWISE SPECIFIED:  
RESISTORS ARE 0402 PACKAGE, POWER RATING < 0.5W & TOLERANCE > 1%  
CAPACITORS ARE 0402 PACKAGE & TOLERANCE OF 10%



LEVEL TRANSLATOR FOR SOC\_PLTRST\_N

	DOCUMENT NUMBER: 232-000036	
	TITLE: E3845 : POWER	LIFE 3

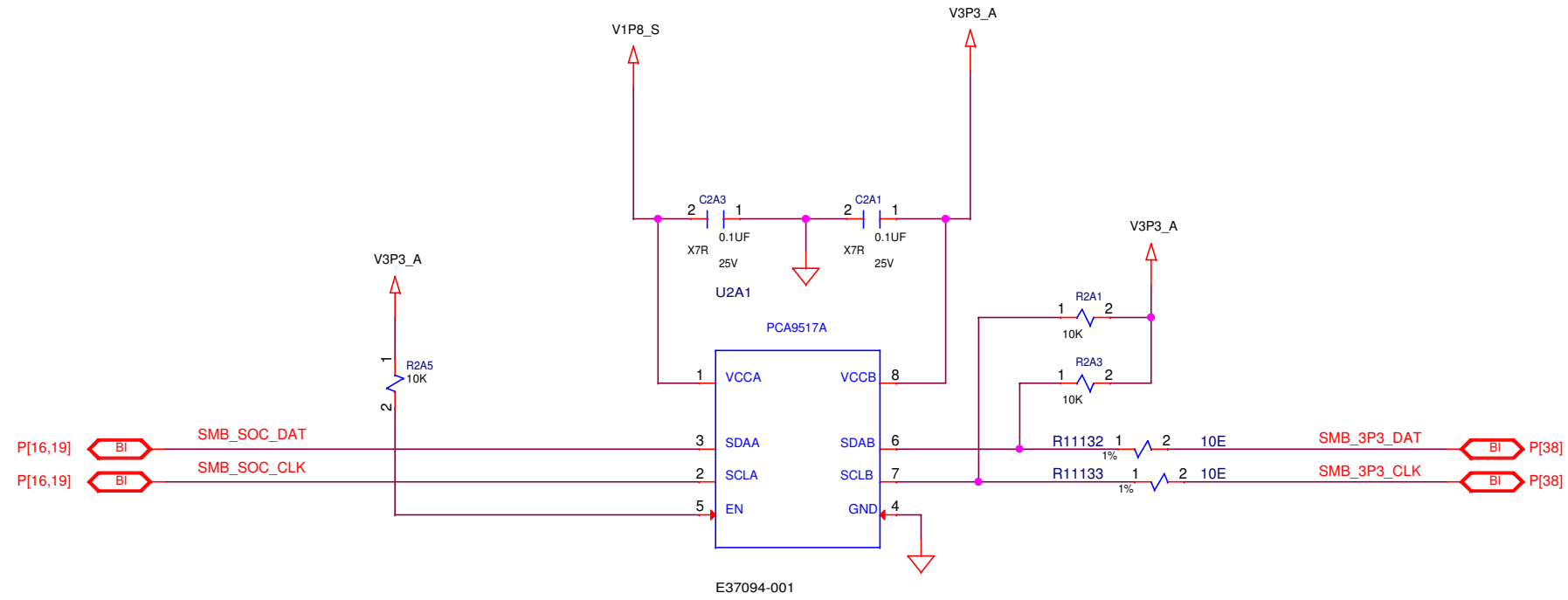
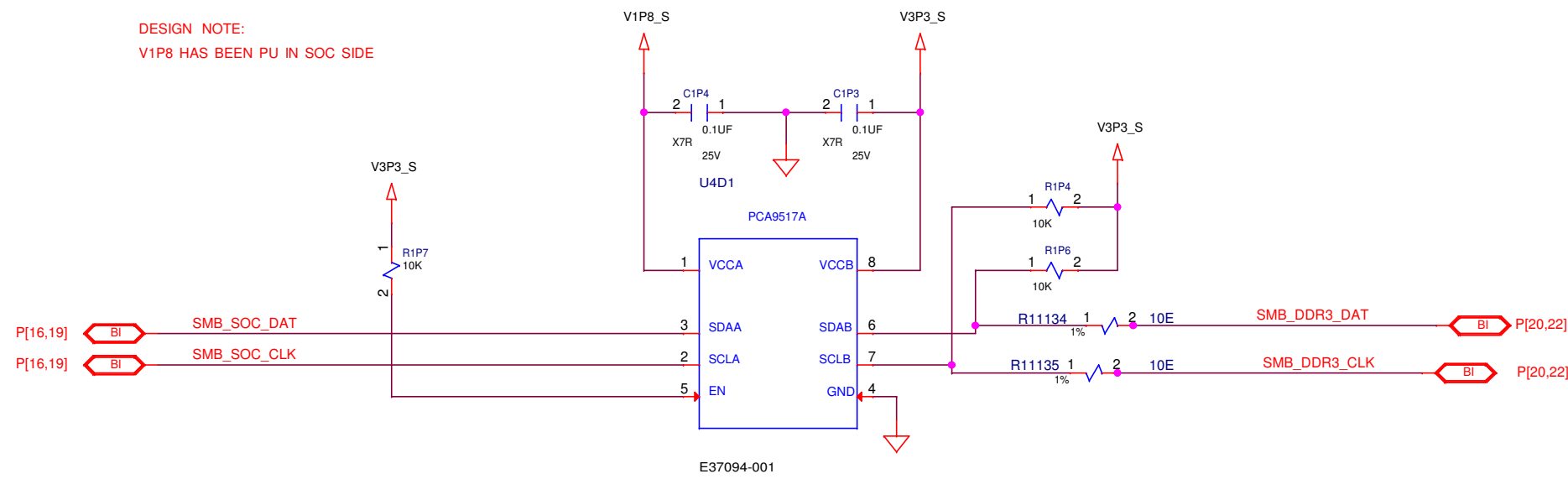
8 7 6 5 4 3 2 1



8 7 6 5 4 3 2 1

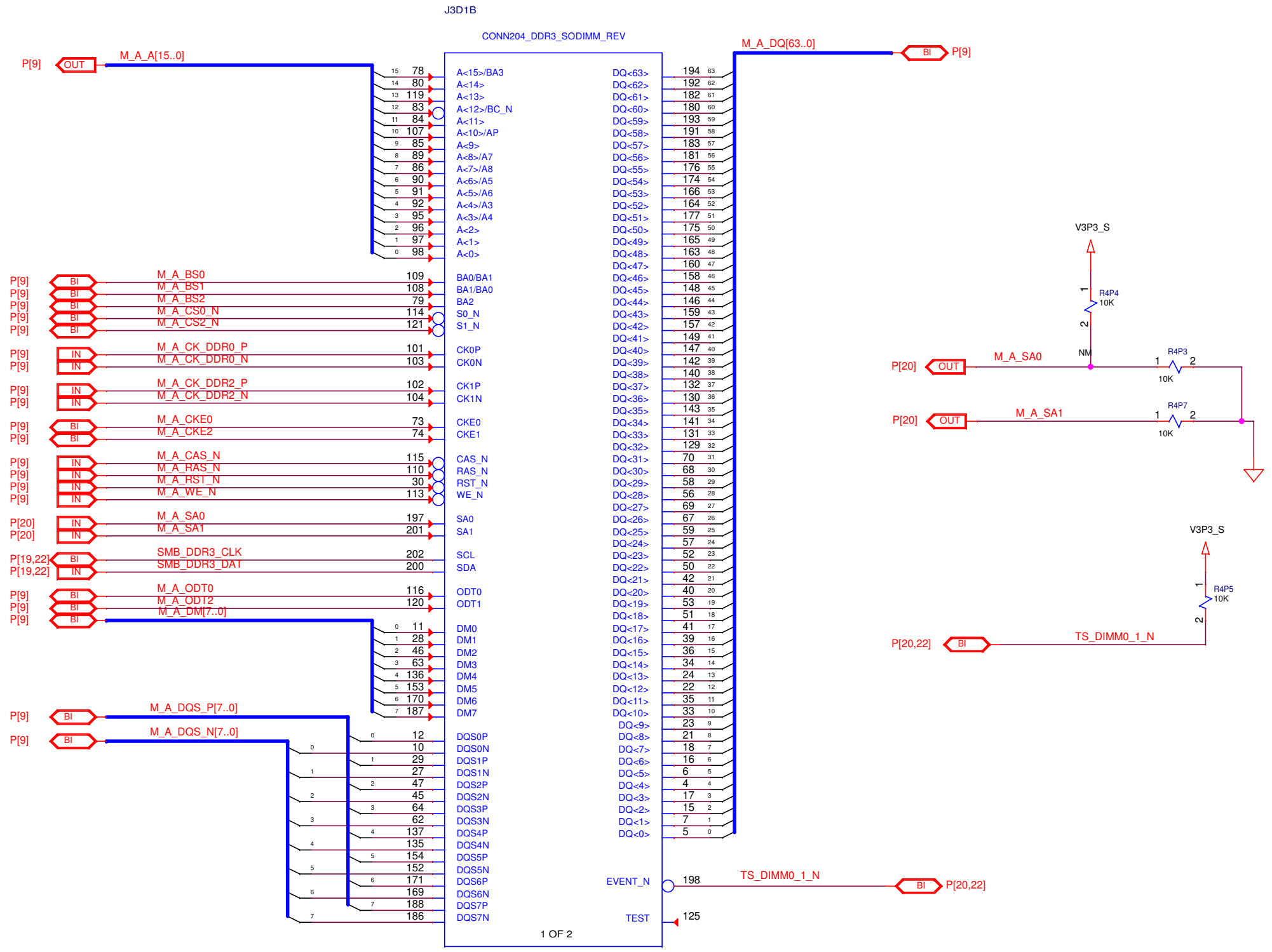
UNLESS OTHERWISE SPECIFIED:  
RESISTORS ARE 0402 PACKAGE, POWER RATING < 0.5W & TOLERANCE > 1%  
CAPACITORS ARE 0402 PACKAGE & TOLERANCE OF 10%

DESIGN NOTE:  
V1P8 HAS BEEN PU IN SOC SIDE

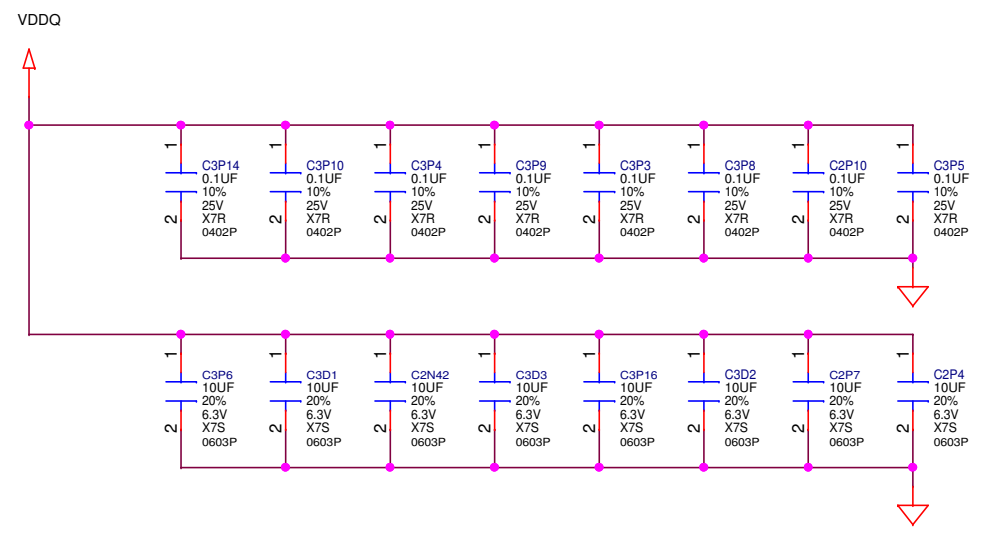
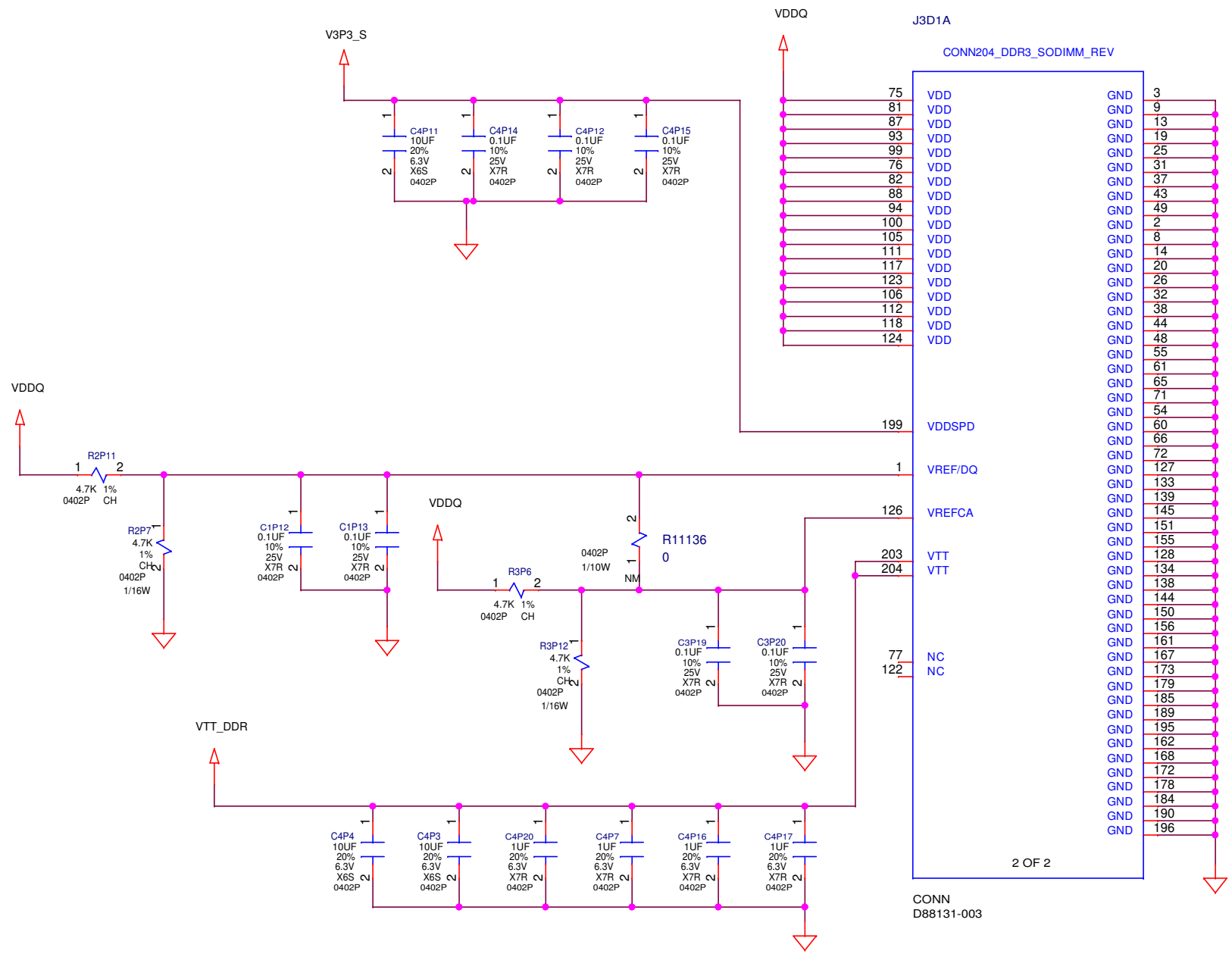


CHANNEL A DIMM A0 1 of 2

UNLESS OTHERWISE SPECIFIED:  
RESISTORS ARE 0402 PACKAGE, POWER RATING < 0.5W & TOLERANCE > 1%  
CAPACITORS ARE 0402 PACKAGE & TOLERANCE OF 10%

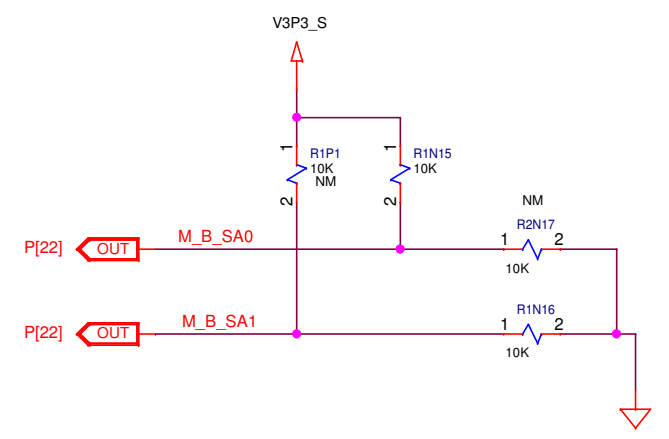
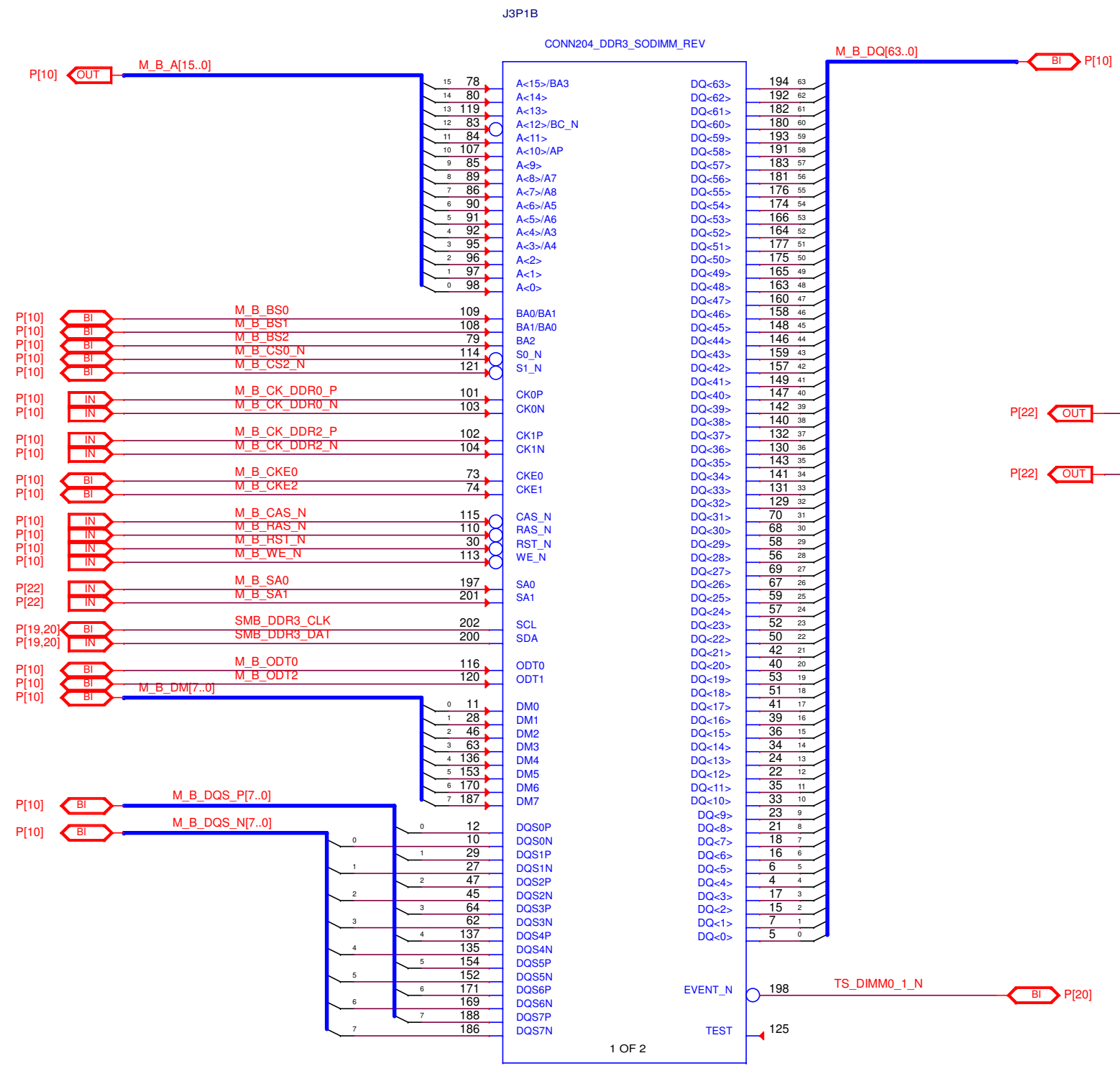


CHANNEL A DIMM A0 2 of 2



UNLESS OTHERWISE SPECIFIED:  
RESISTORS ARE 0402 PACKAGE, POWER RATING < 0.5W & TOLERANCE > 1%  
CAPACITORS ARE 0402 PACKAGE & TOLERANCE OF 10%

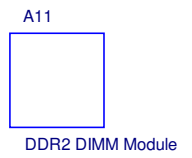
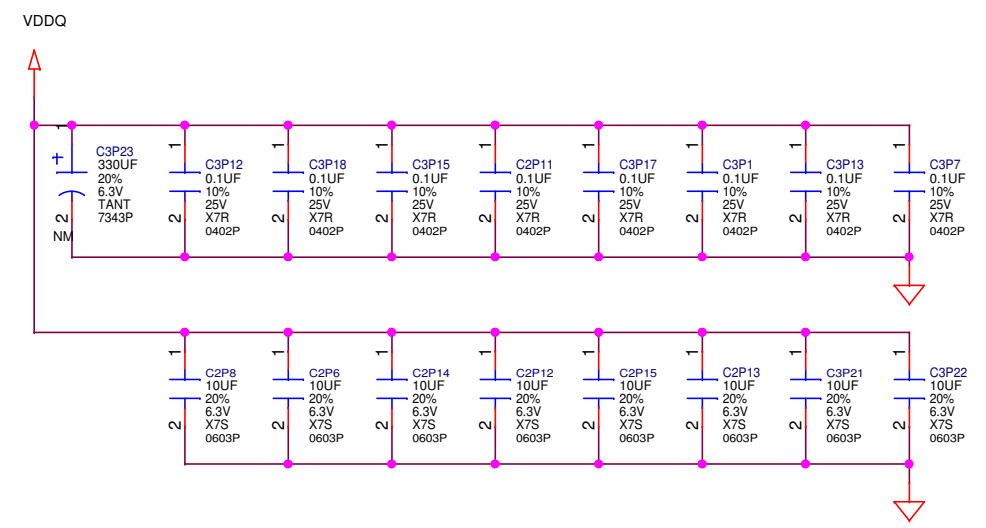
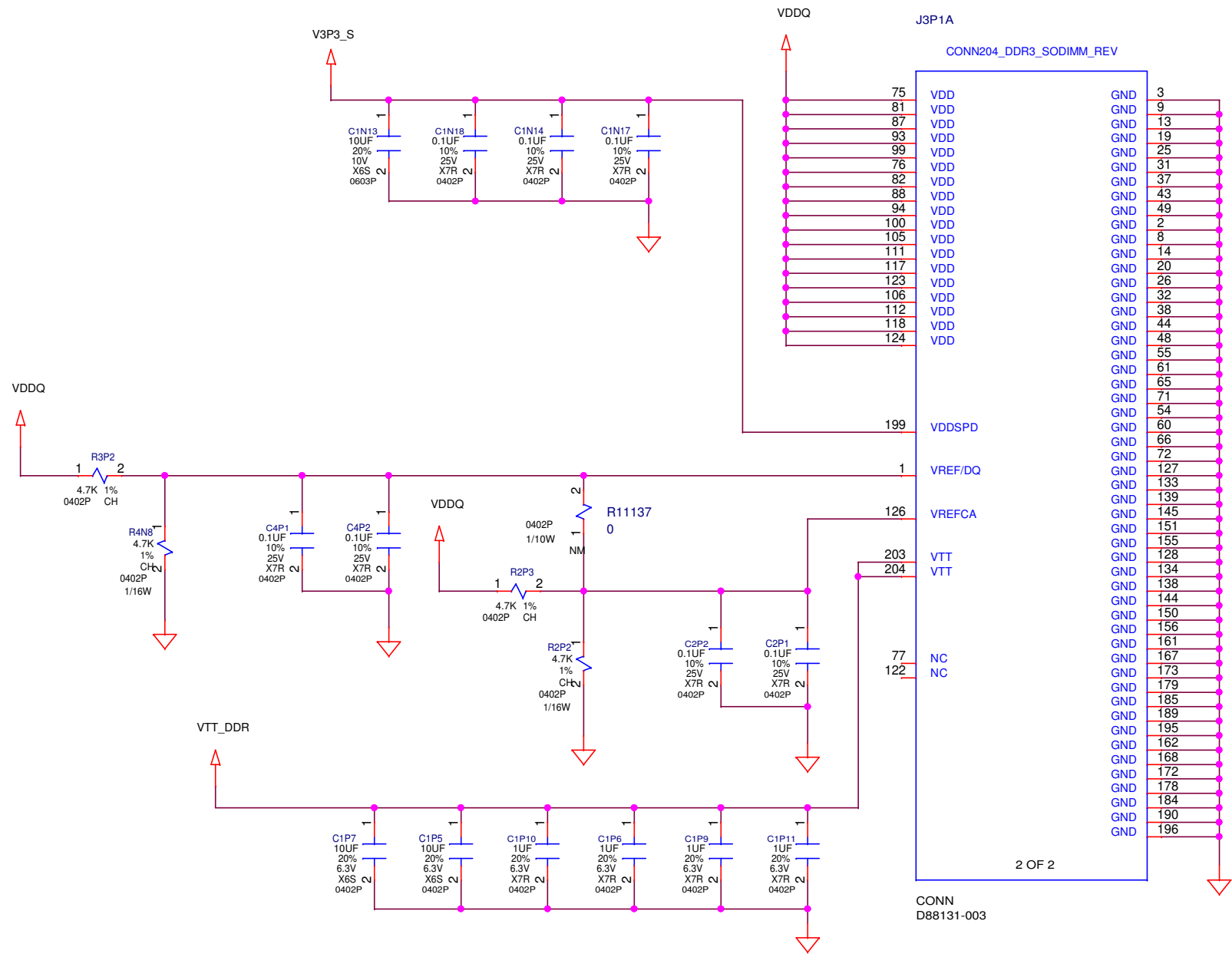
CHANNEL B DIMM B0 1 OF 2



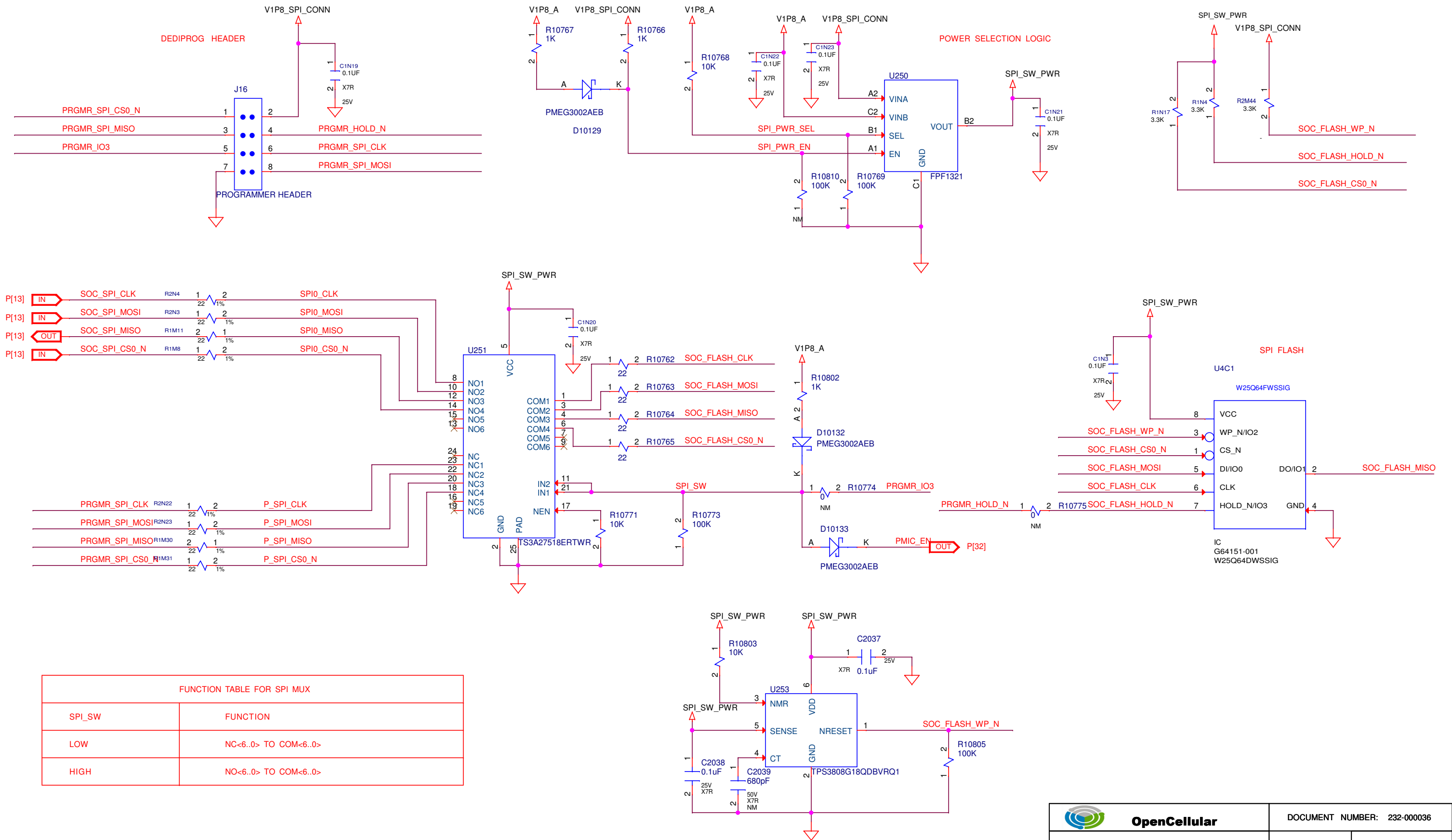
CONN  
D88131-003

	DOCUMENT NUMBER: 232-000036	
	TITLE: DDR DIMMO CH B 1 OF 2	LIFE 3

CHANNEL B DIMM B0 2 OF 2



UNLESS OTHERWISE SPECIFIED:  
RESISTORS ARE 0402 PACKAGE, POWER RATING < 0.5W & TOLERANCE > 1%  
CAPACITORS ARE 0402 PACKAGE & TOLERANCE OF 10%

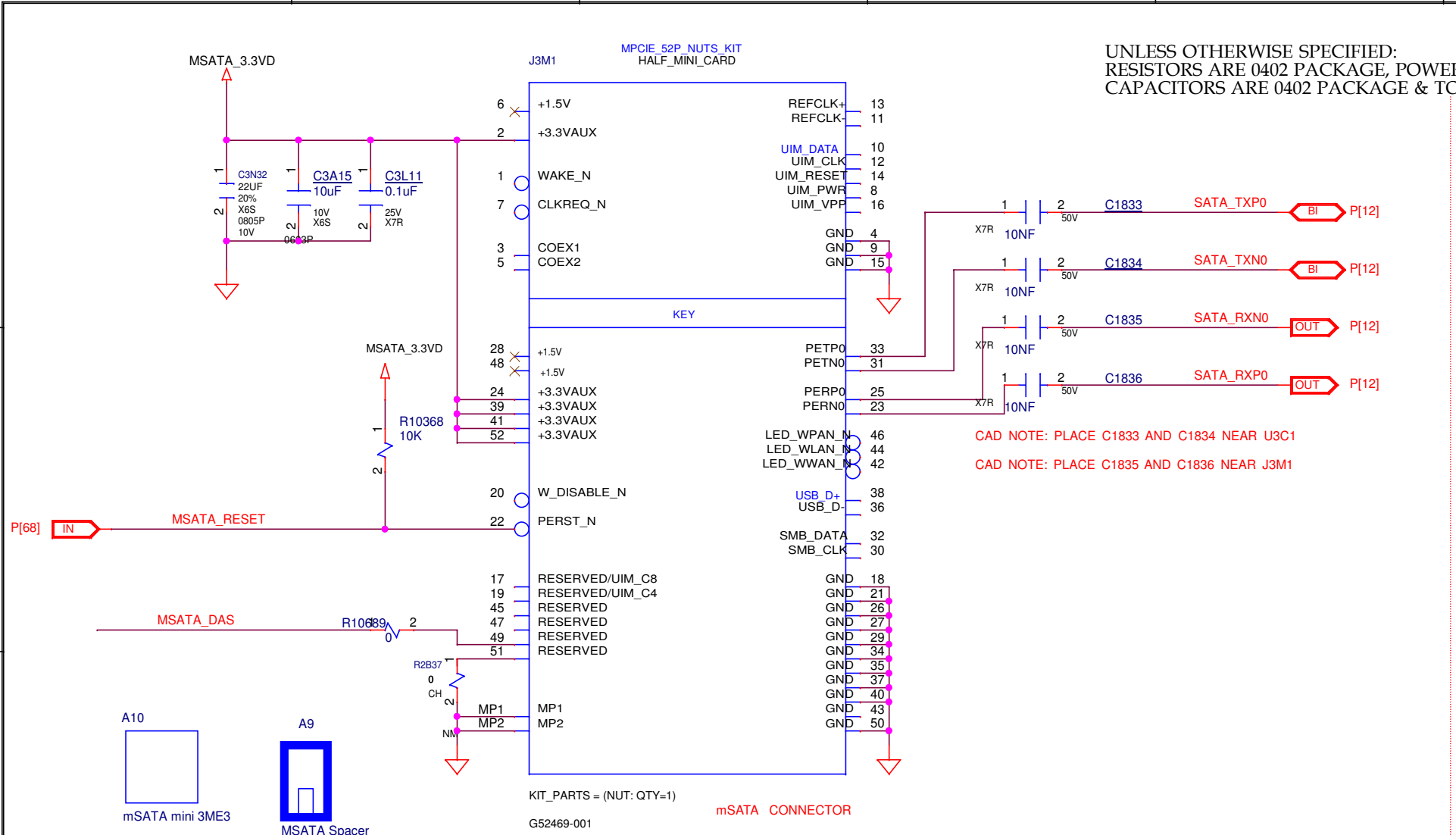


FUNCTION TABLE FOR SPI MUX

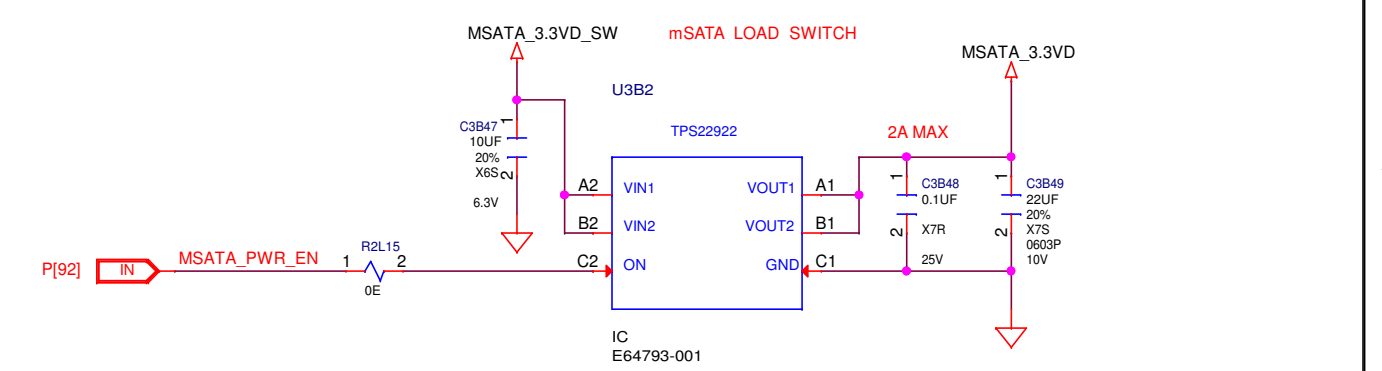
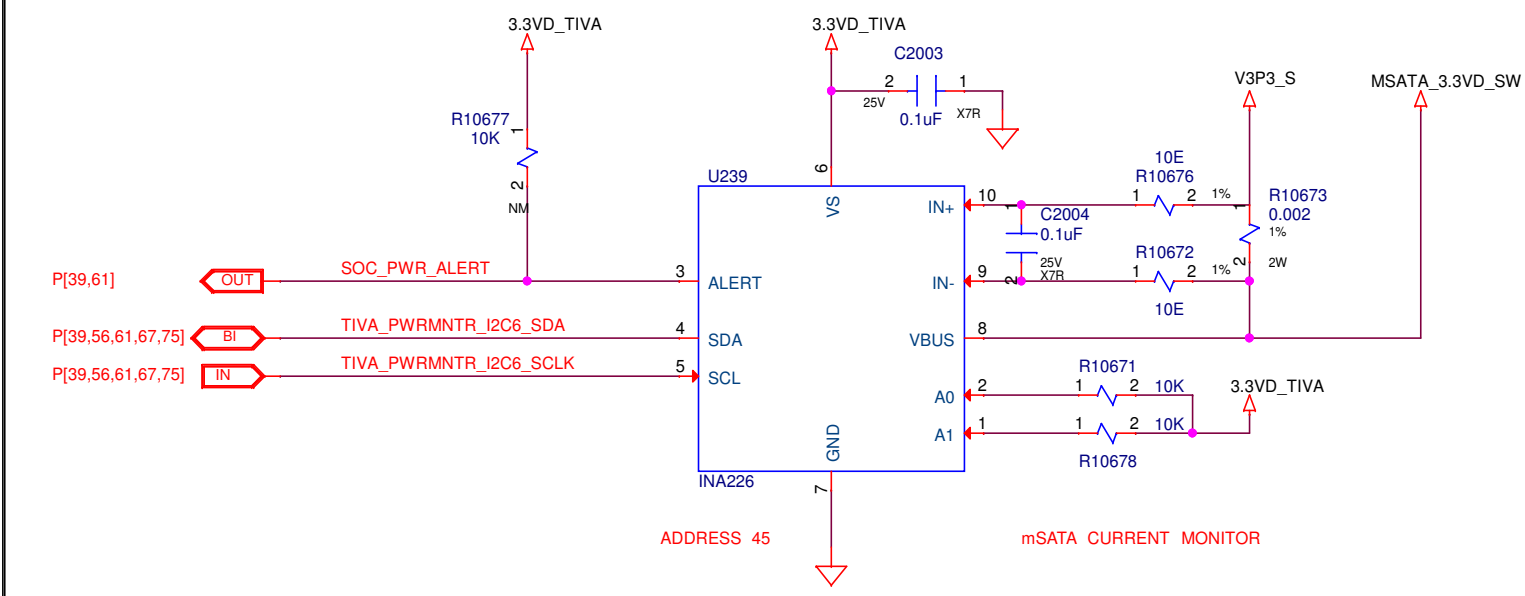
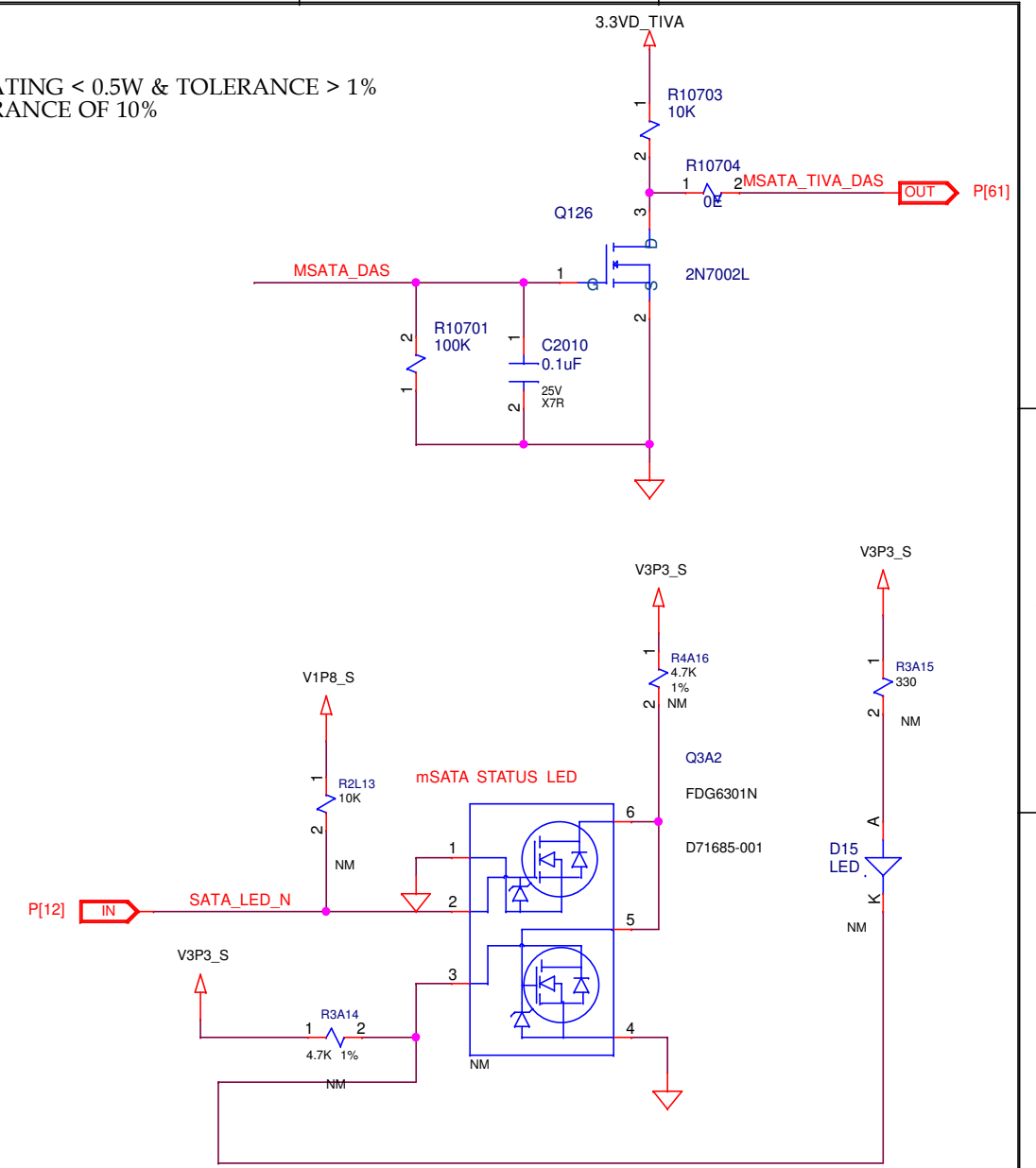
SPI_SW	FUNCTION
LOW	NC<6..0> TO COM<6..0>
HIGH	NO<6..0> TO COM<6..0>



UNLESS OTHERWISE SPECIFIED:  
 RESISTORS ARE 0402 PACKAGE, POWER RATING < 0.5W & TOLERANCE > 1%  
 CAPACITORS ARE 0402 PACKAGE & TOLERANCE OF 10%

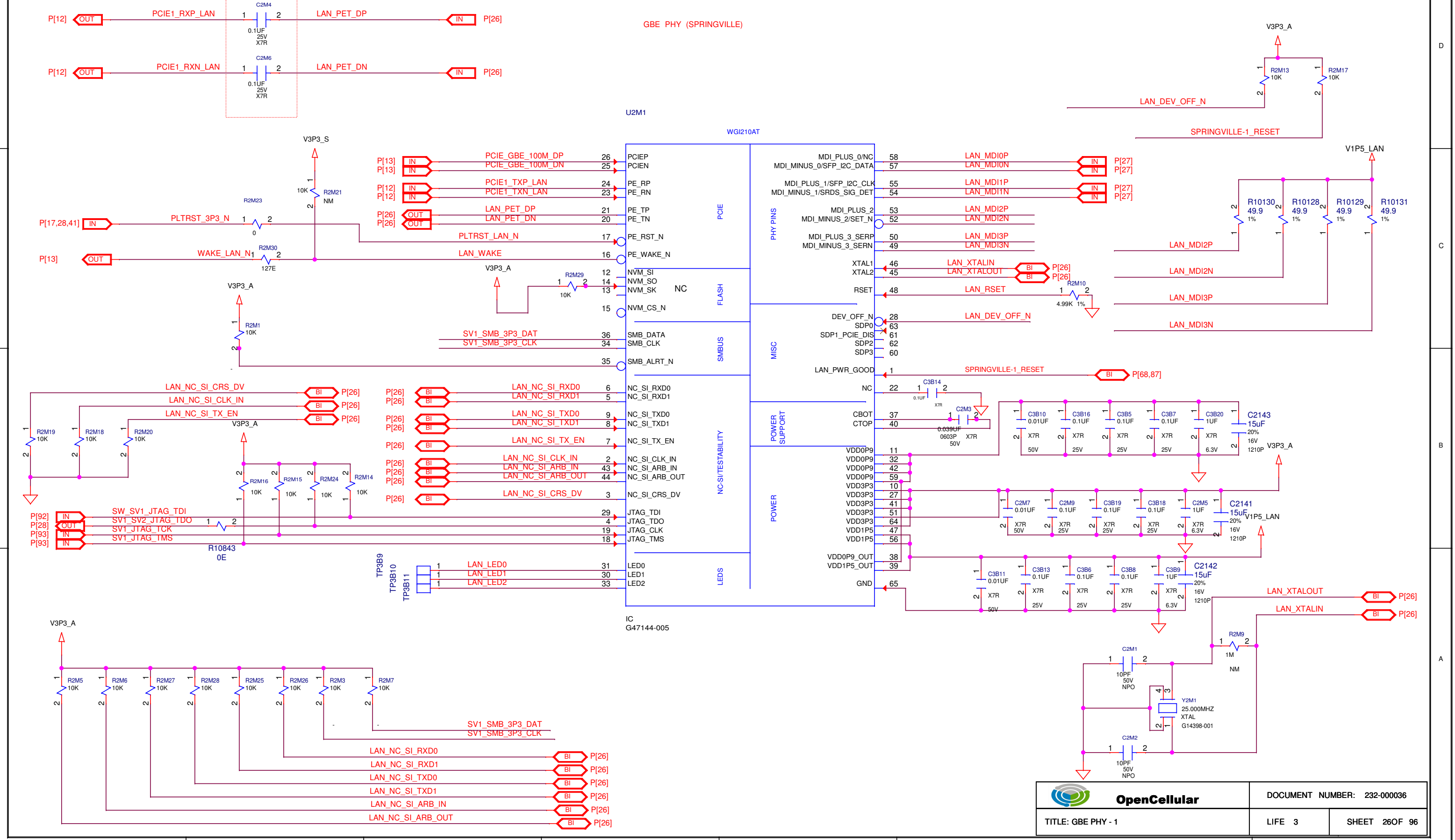


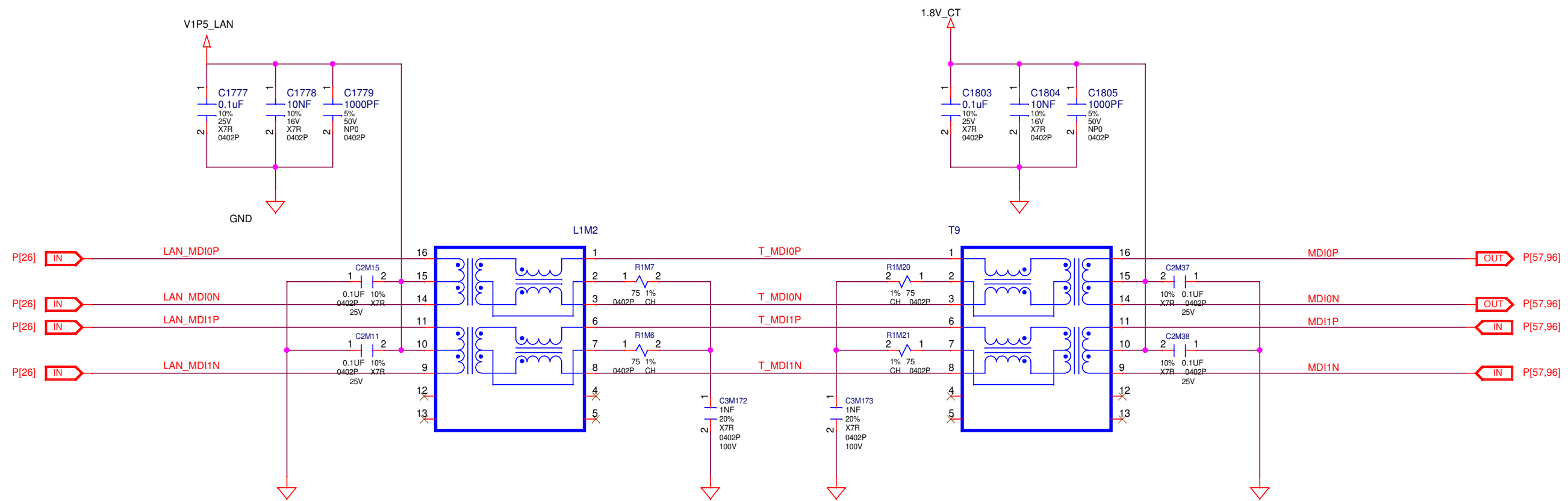
CAD NOTE: PLACE C1833 AND C1834 NEAR U3C1  
 CAD NOTE: PLACE C1835 AND C1836 NEAR J3M1



UNLESS OTHERWISE SPECIFIED:  
RESISTORS ARE 0402 PACKAGE, POWER RATING < 0.5W & TOLERANCE > 1%  
CAPACITORS ARE 0402 PACKAGE & TOLERANCE OF 10%

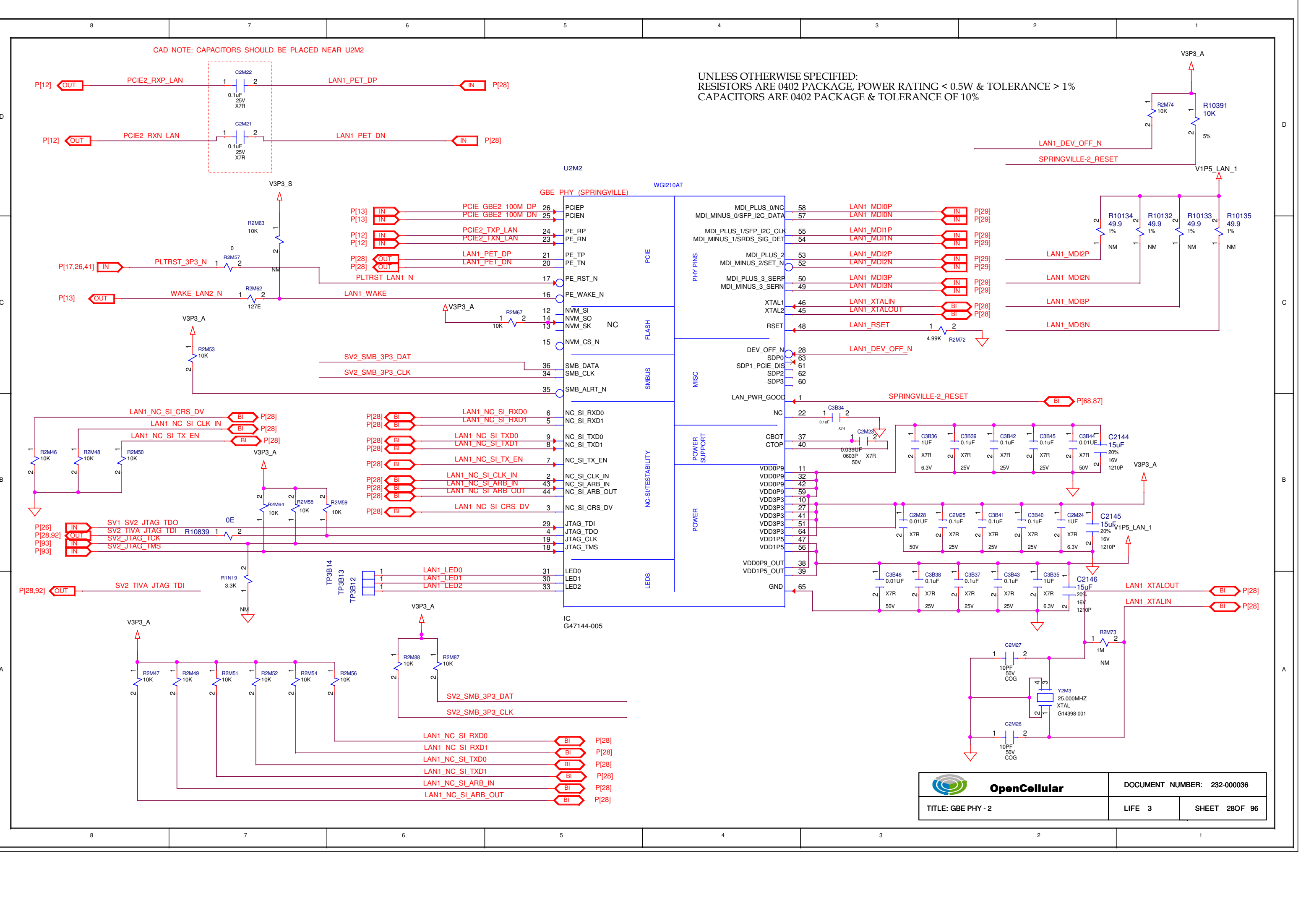
CAD NOTE: CAPACITORS SHOULD BE PLACED NEAR U2M1

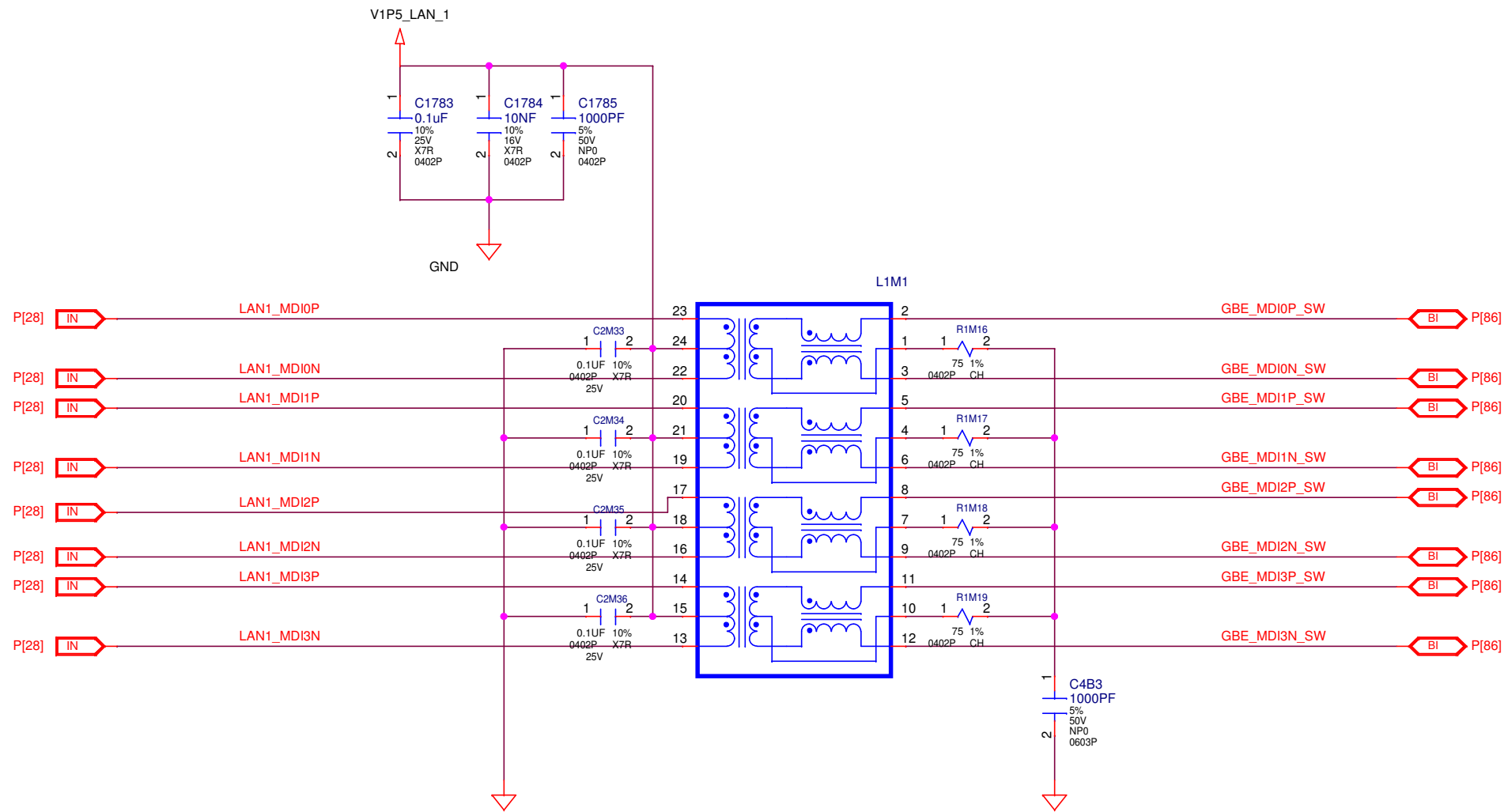


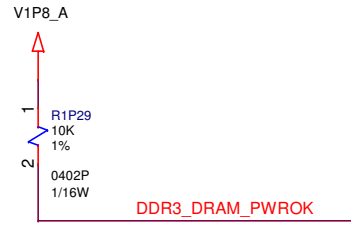
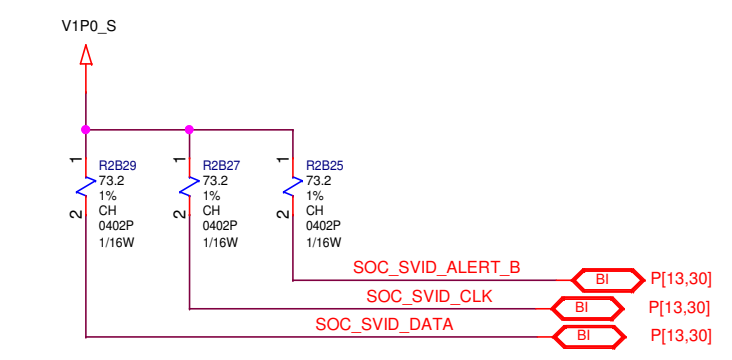
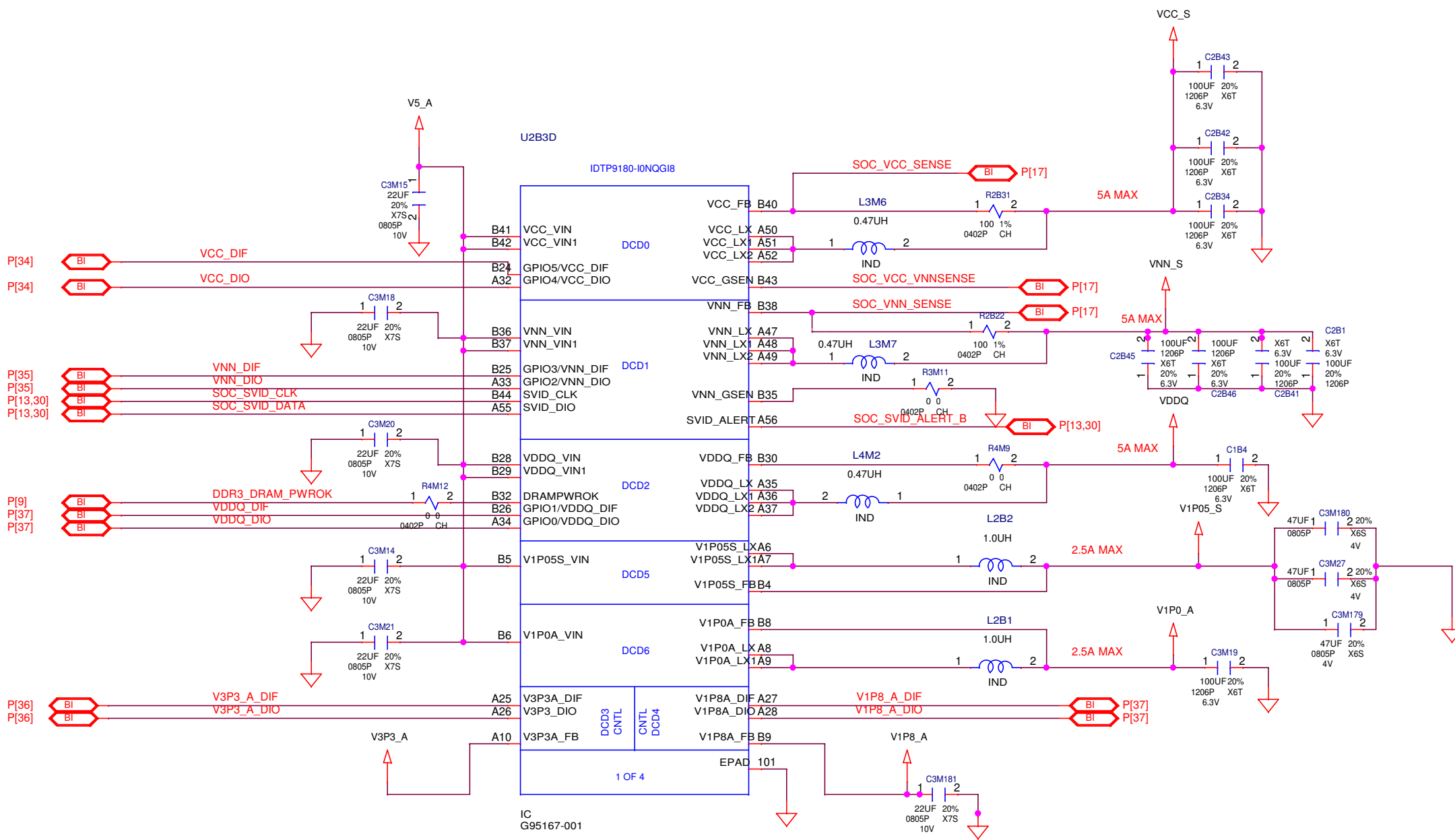


CAD NOTE: CAPACITORS SHOULD BE PLACED NEAR U2M2

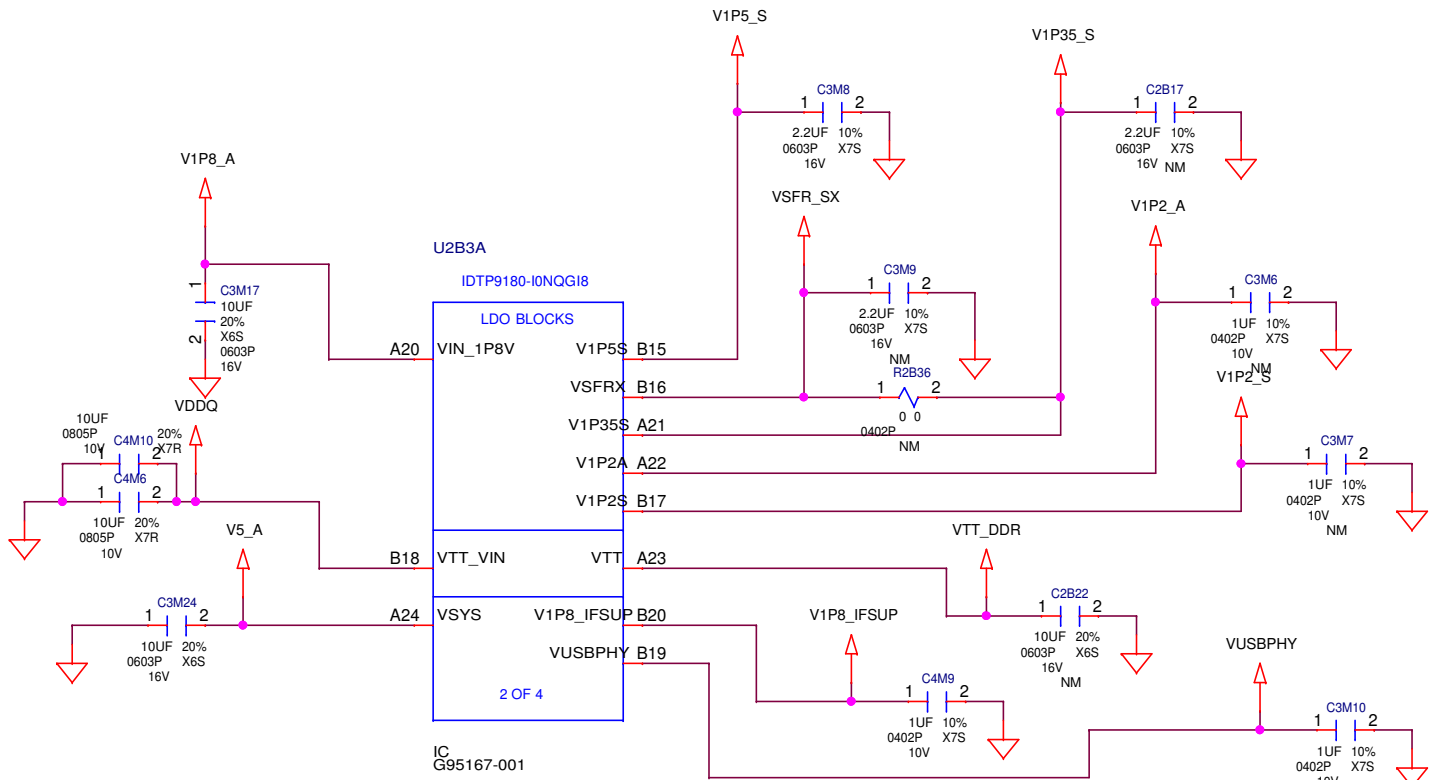
UNLESS OTHERWISE SPECIFIED:  
RESISTORS ARE 0402 PACKAGE, POWER RATING < 0.5W & TOLERANCE > 1%  
CAPACITORS ARE 0402 PACKAGE & TOLERANCE OF 10%



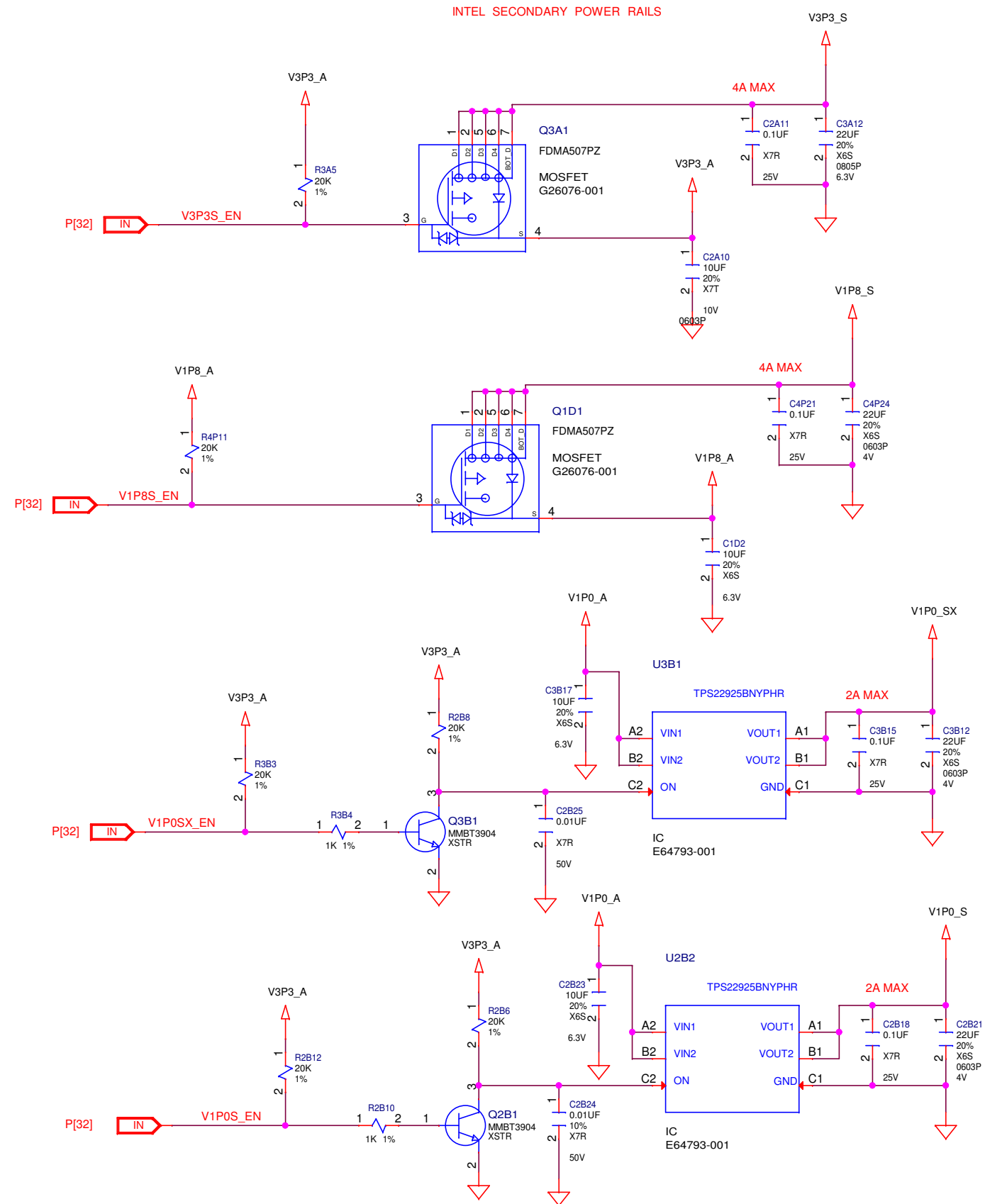
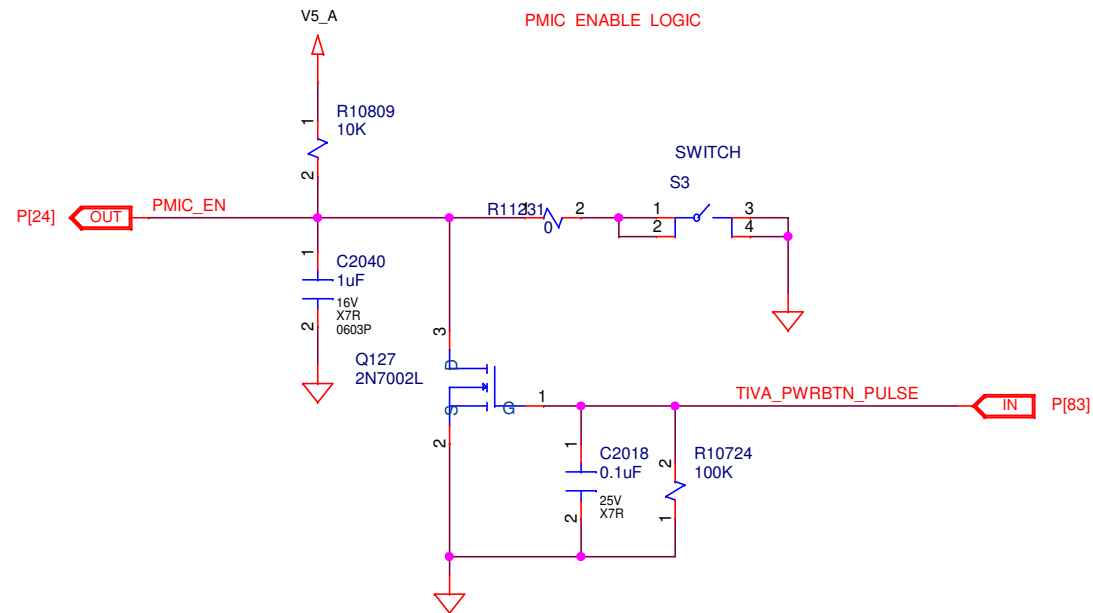
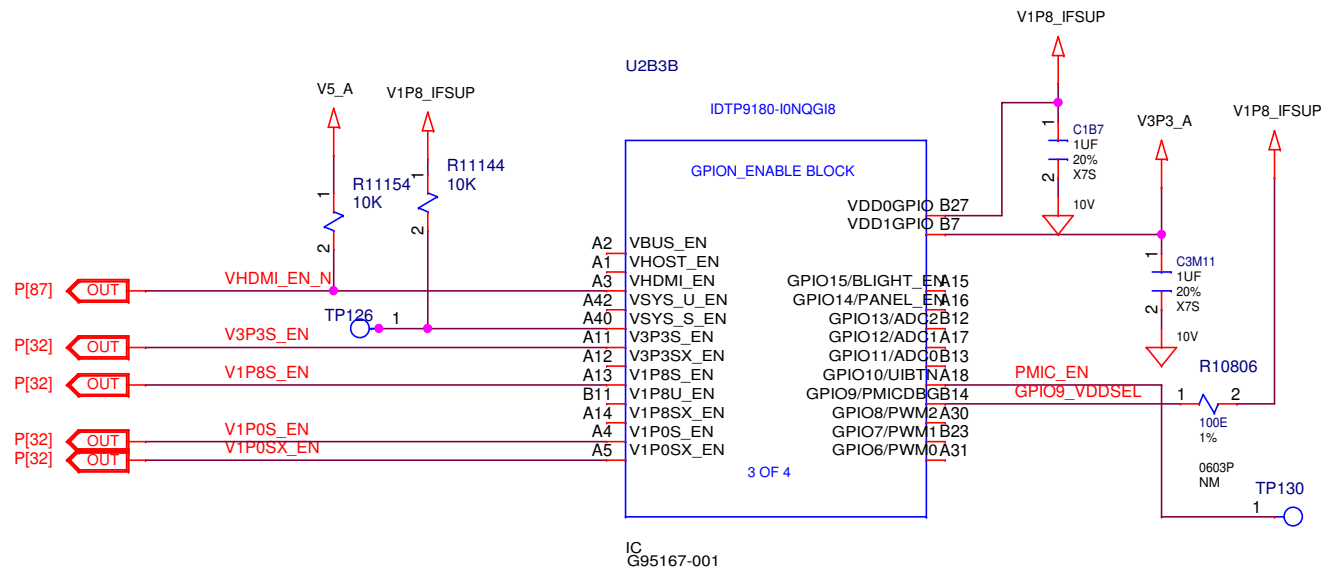




CAD NOTE:  
PLACE ALL CAPS NEAR TO U2B3



UNLESS OTHERWISE SPECIFIED:  
 RESISTORS ARE 0402 PACKAGE, POWER RATING < 0.5W & TOLERANCE > 1%  
 CAPACITORS ARE 0402 PACKAGE & TOLERANCE OF 10%





8 7 6 5 4 3 2 1

D

C

B

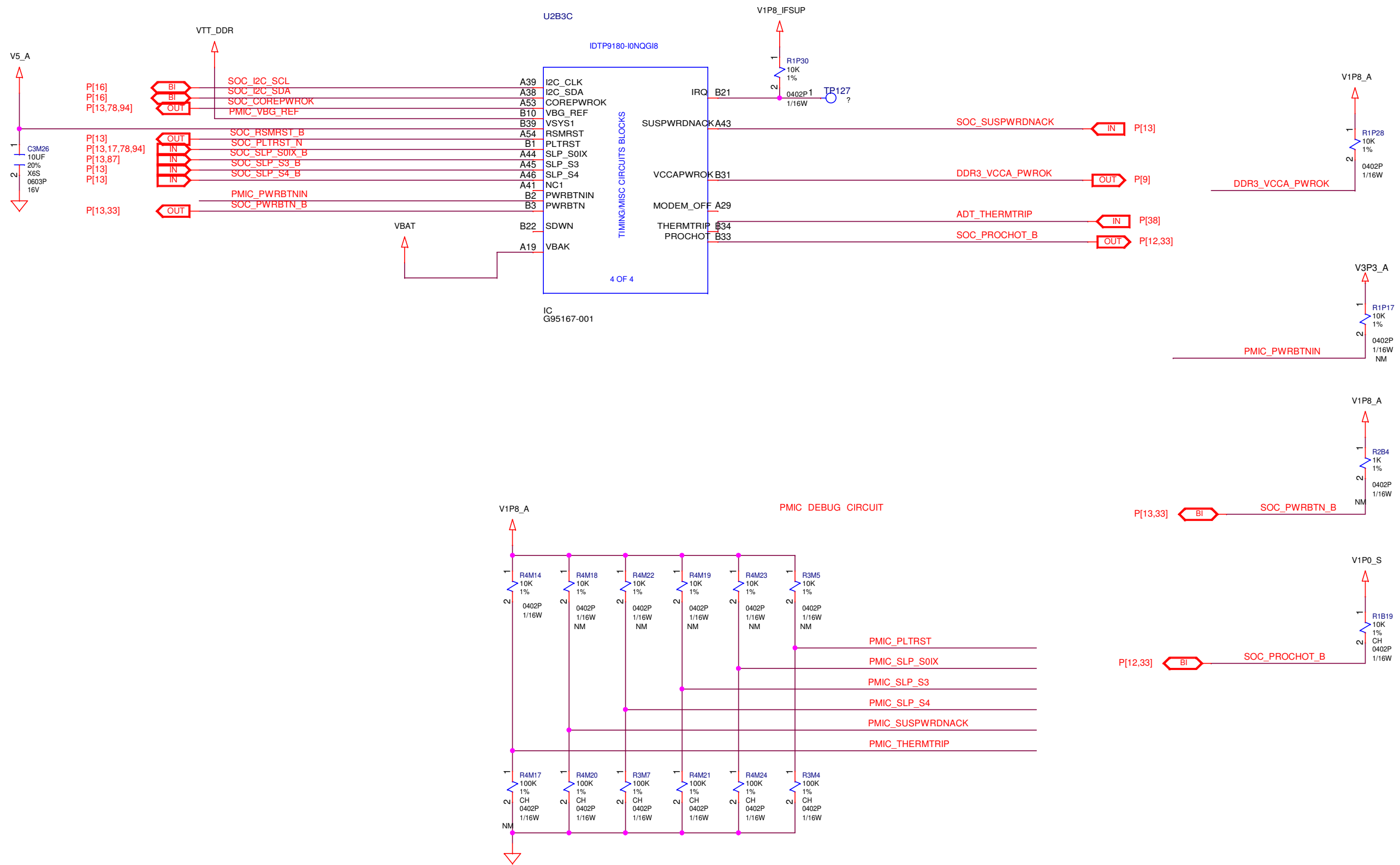
A

D

C

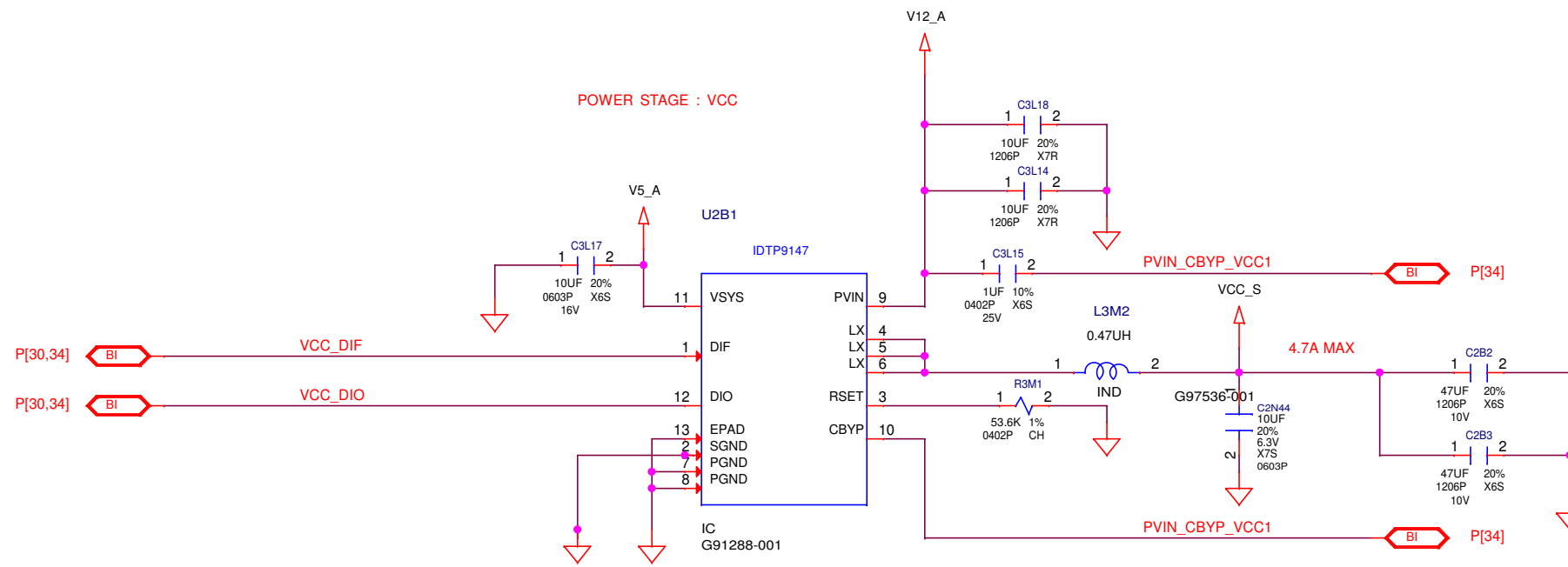
B

A



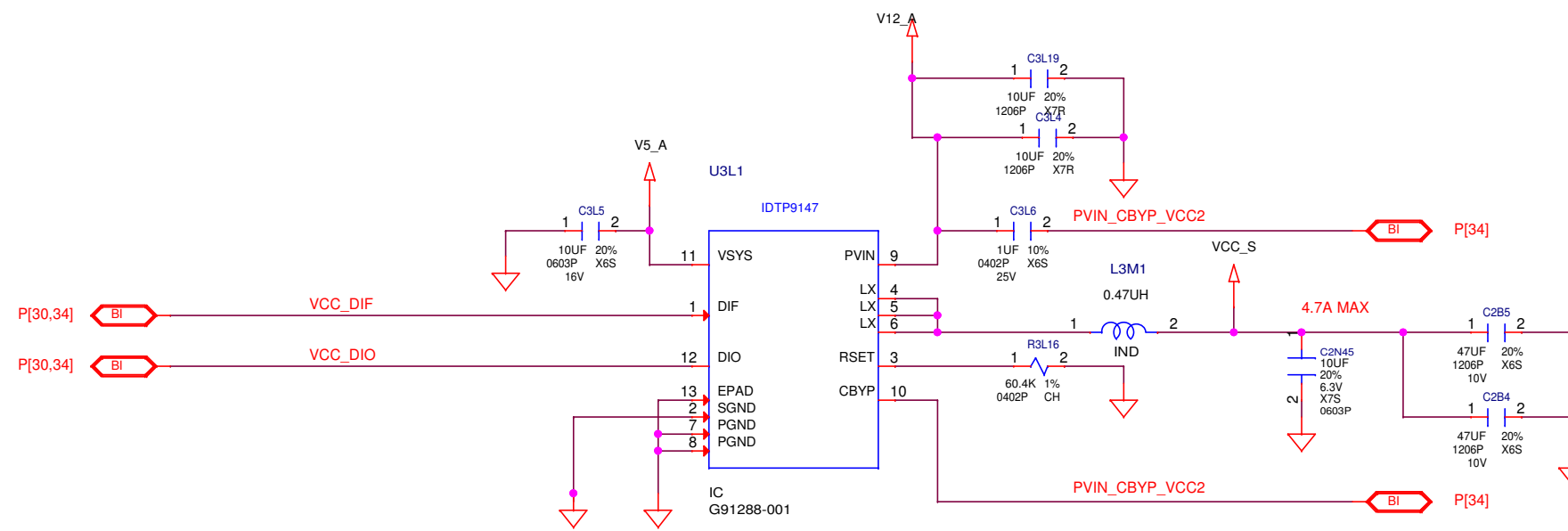
	DOCUMENT NUMBER: 232-000036	
	TITLE: PMIC	LIFE 3

8 7 6 5 4 3 2 1

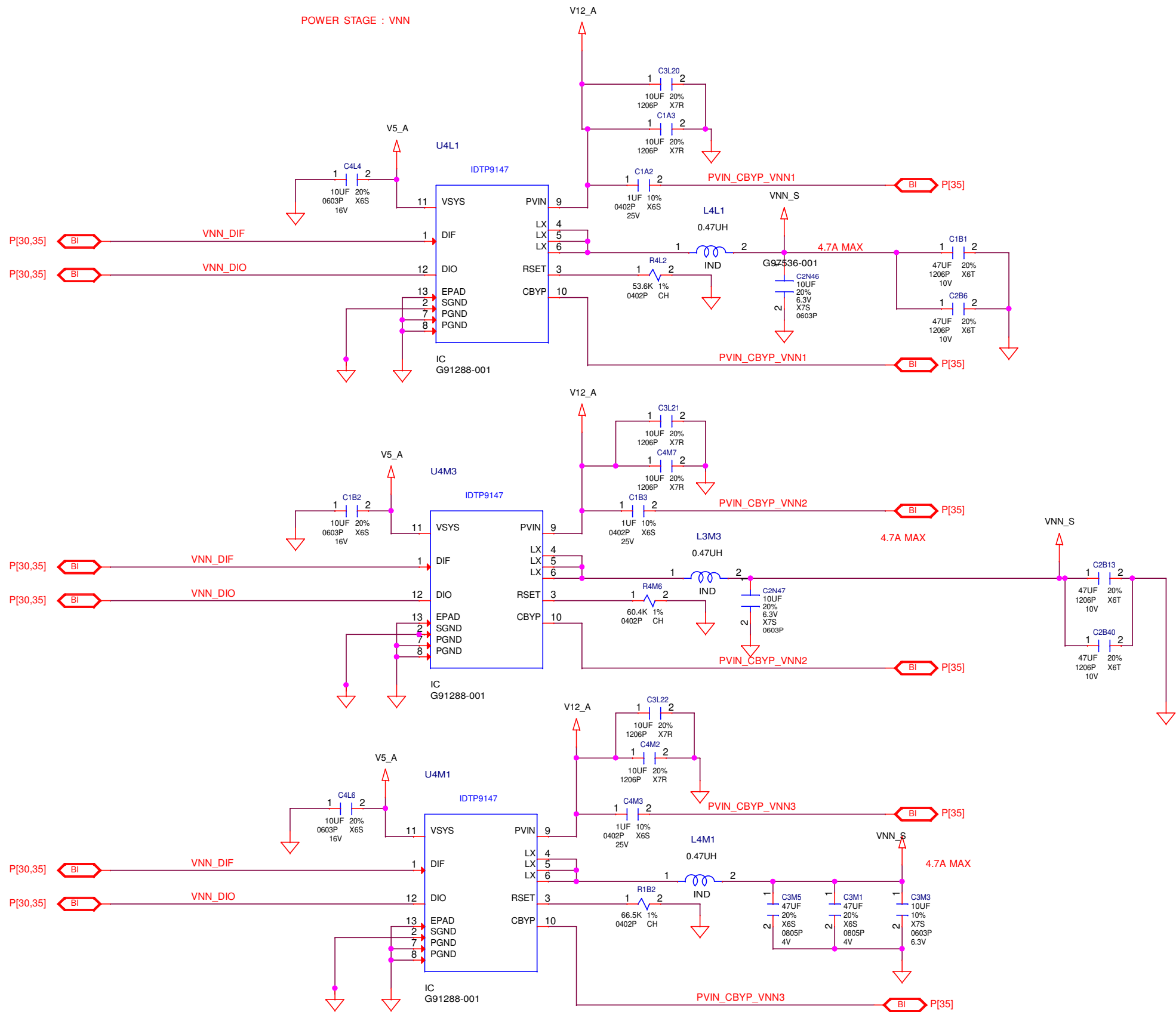


R <sub>SET</sub> [kΩ]	ID
53.6	0
60.4	1
66.5	2
73.2	3

Table 8 – Recommended R<sub>SET</sub> values



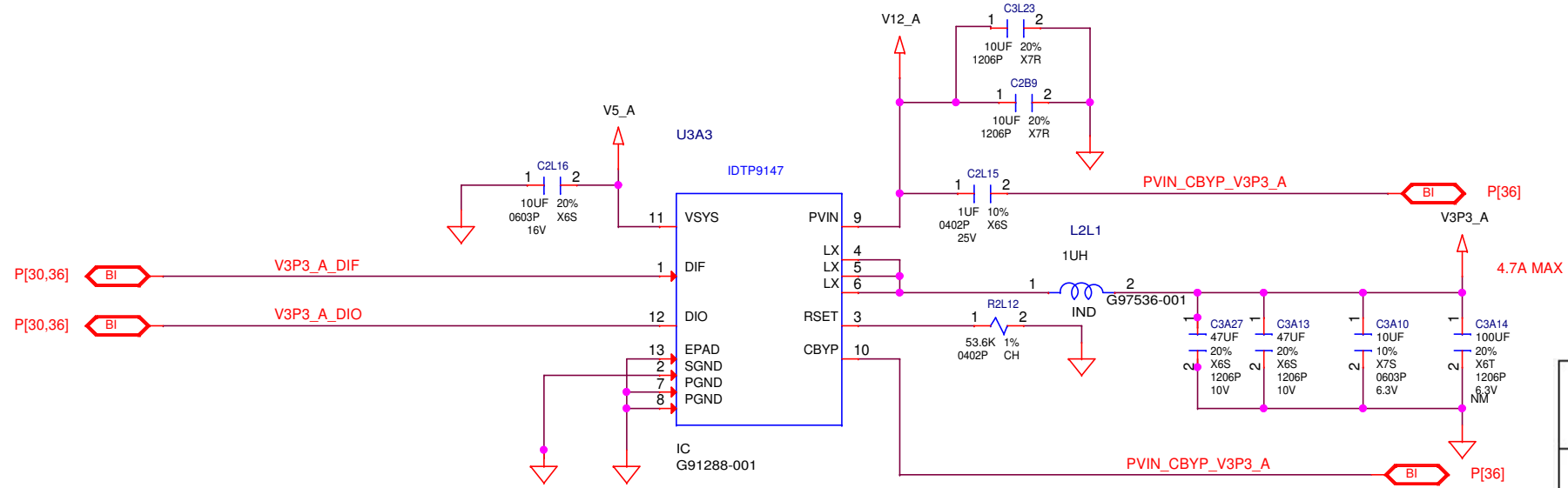
POWER STAGE : VNN



R <sub>SET</sub> [kΩ]	ID
53.6	0
60.4	1
66.5	2
73.2	3

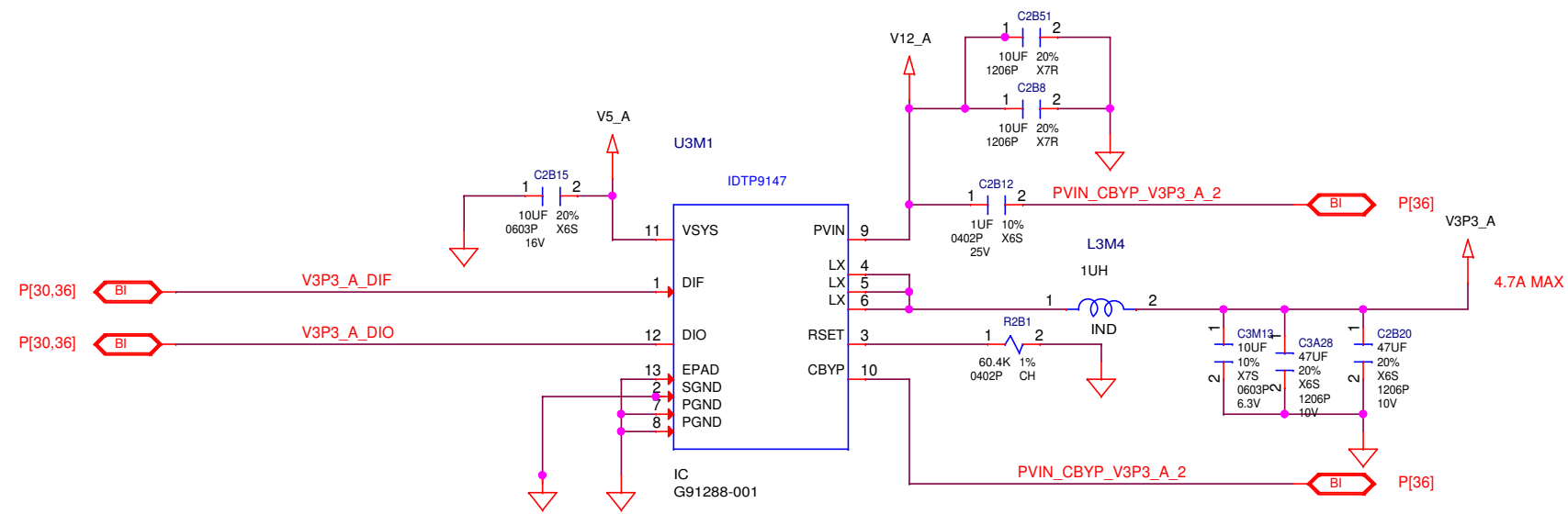
Table 8 – Recommended R<sub>SET</sub> values

POWER STAGE : V3P3\_A

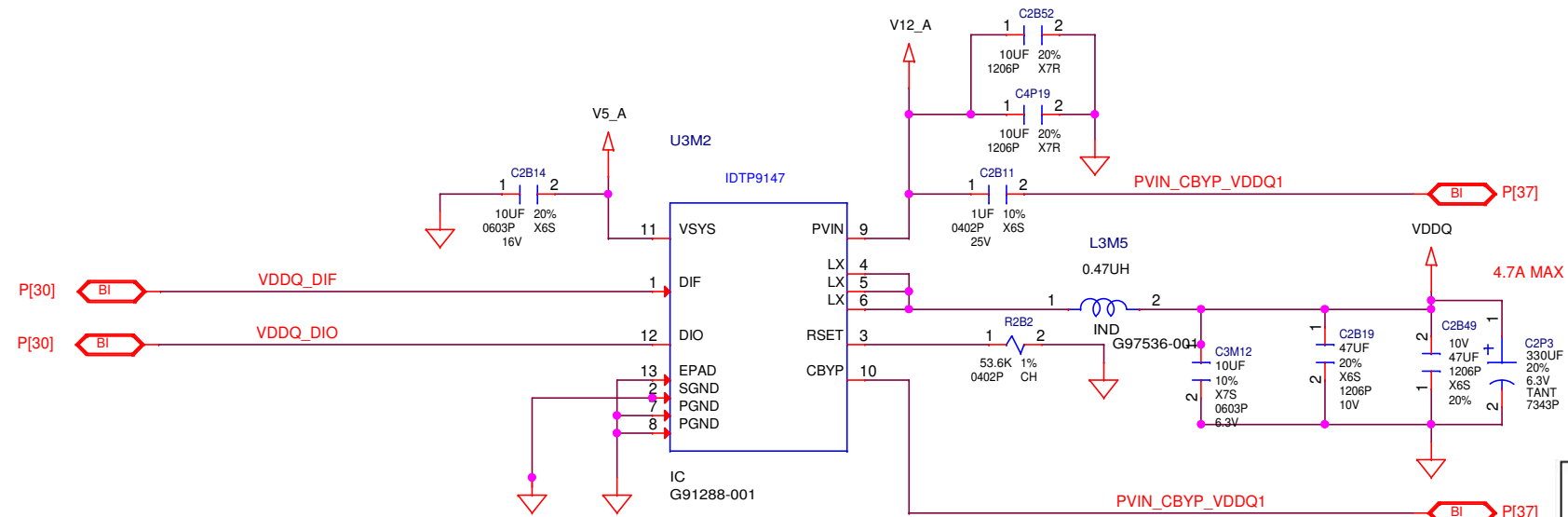


R <sub>SET</sub> [kΩ]	ID
53.6	0
60.4	1
66.5	2
73.2	3

Table 8 – Recommended R<sub>SET</sub> values



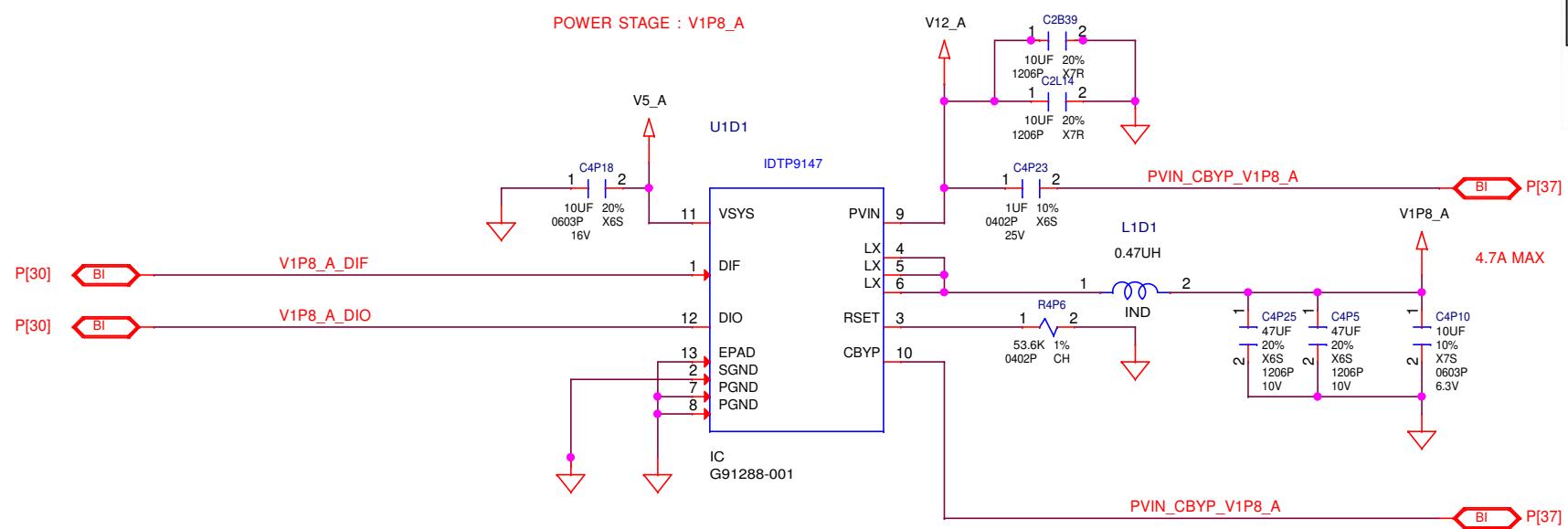
POWER STAGE : VDDQ



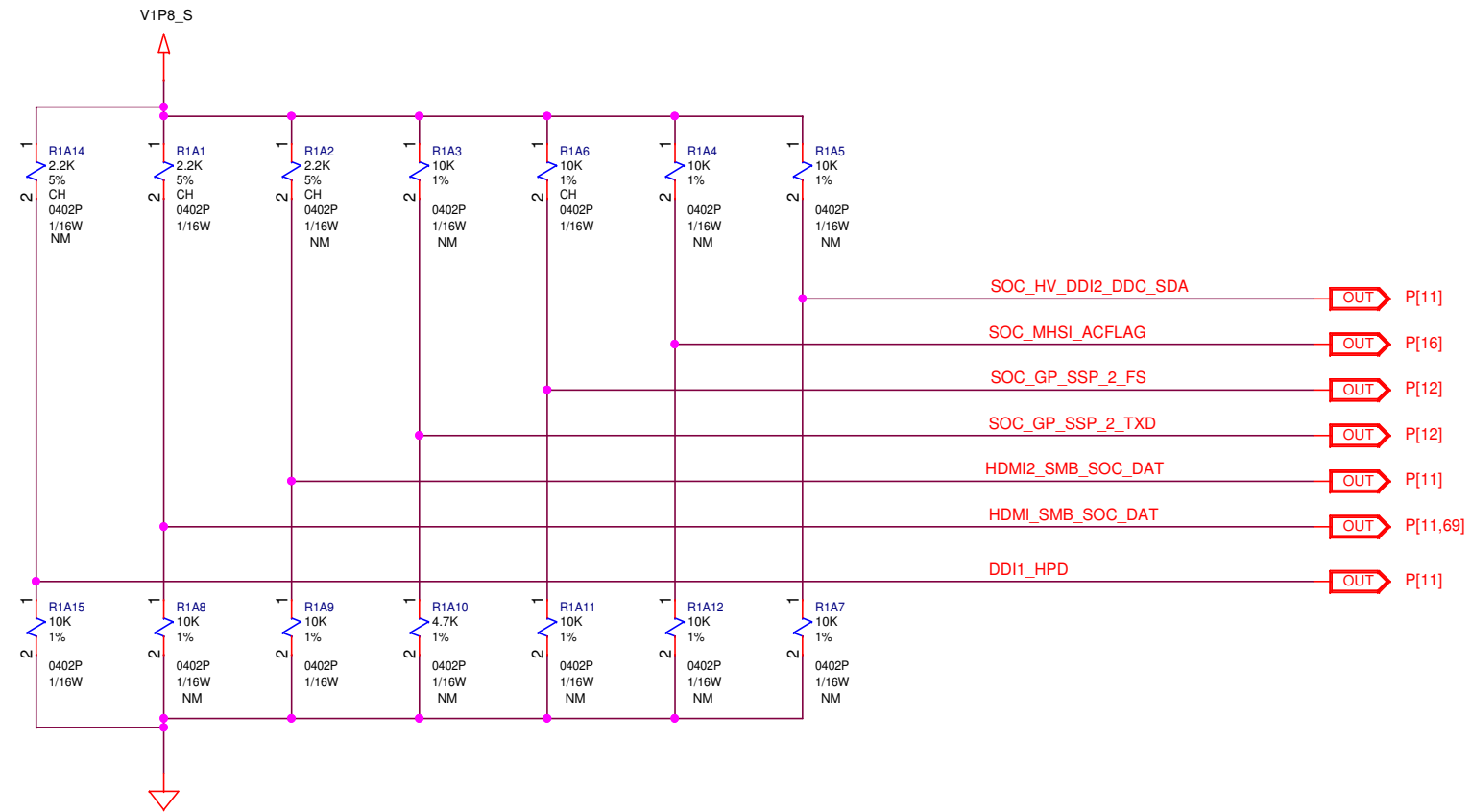
R <sub>SET</sub> [kΩ]	ID
53.6	0
60.4	1
66.5	2
73.2	3

Table 8 – Recommended R<sub>SET</sub> values

POWER STAGE : V1P8\_A



STRAP PINS



STRAPPING OPTION:

HDMI\_SMB\_SOC\_DAT

1: ENABLE DDI0

0: DISABLE DDI0

HDMI2\_SMB\_SOC\_DAT

1: ENABLE DDI1

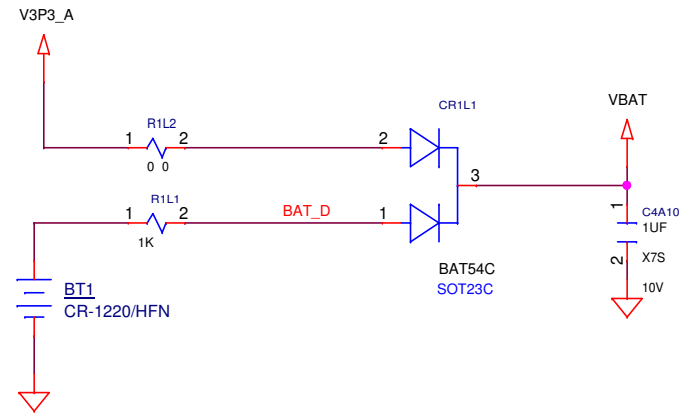
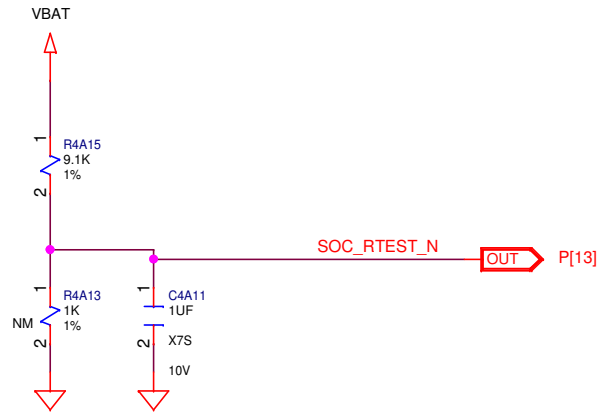
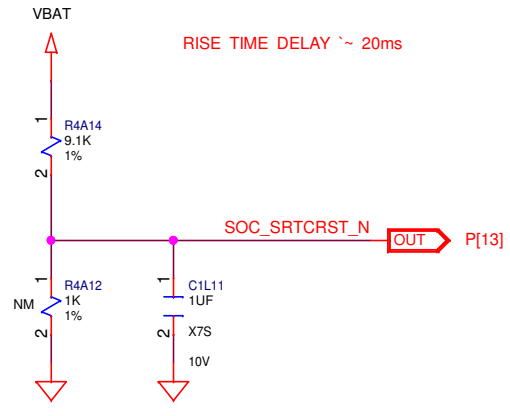
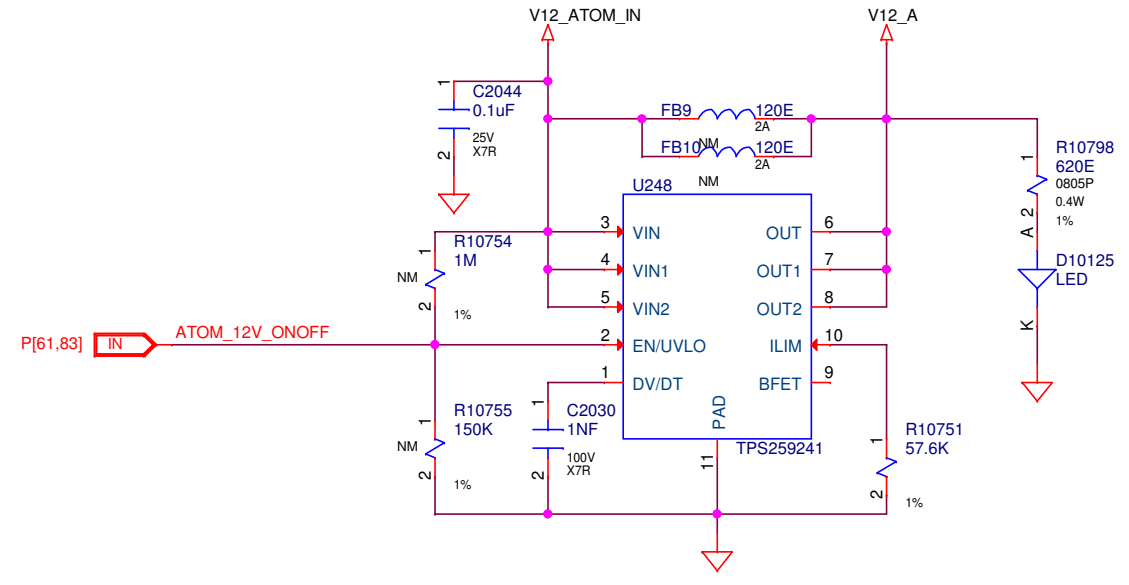
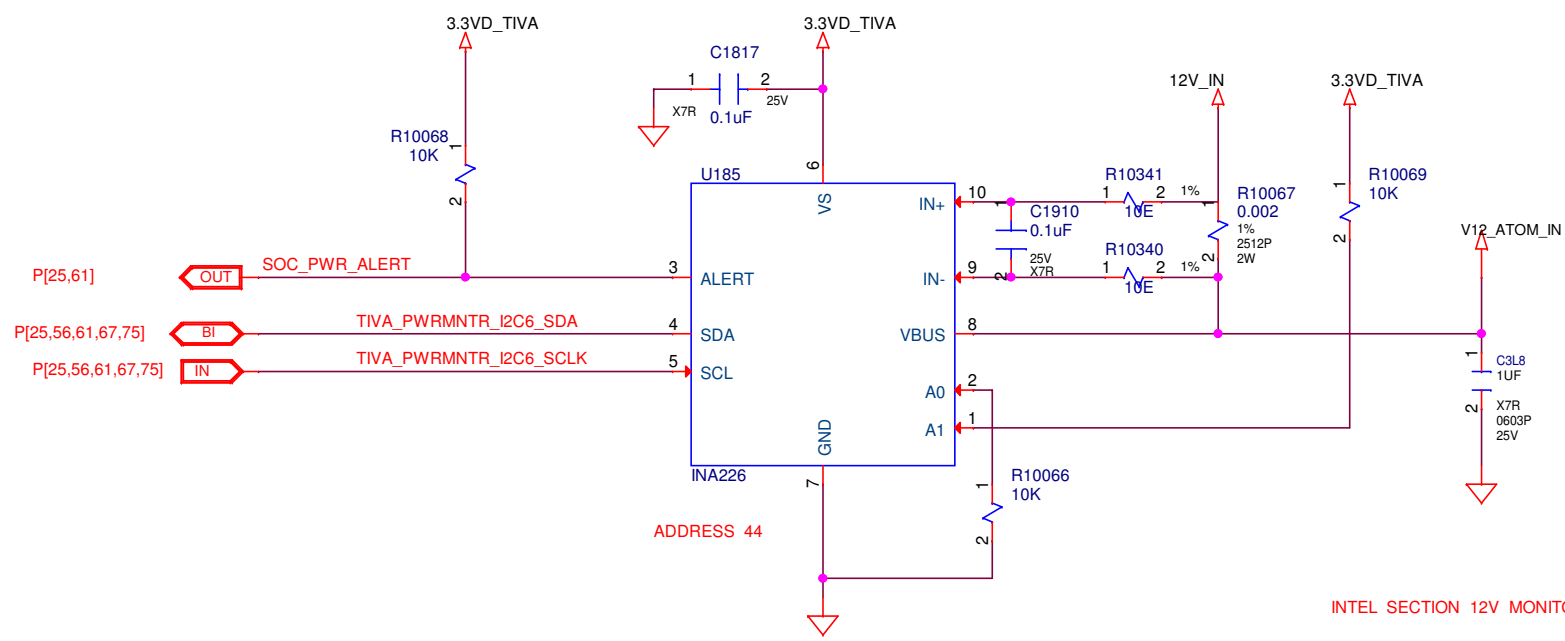
0: DISABLE DDI1

SOC\_GP\_SSP\_2\_FS

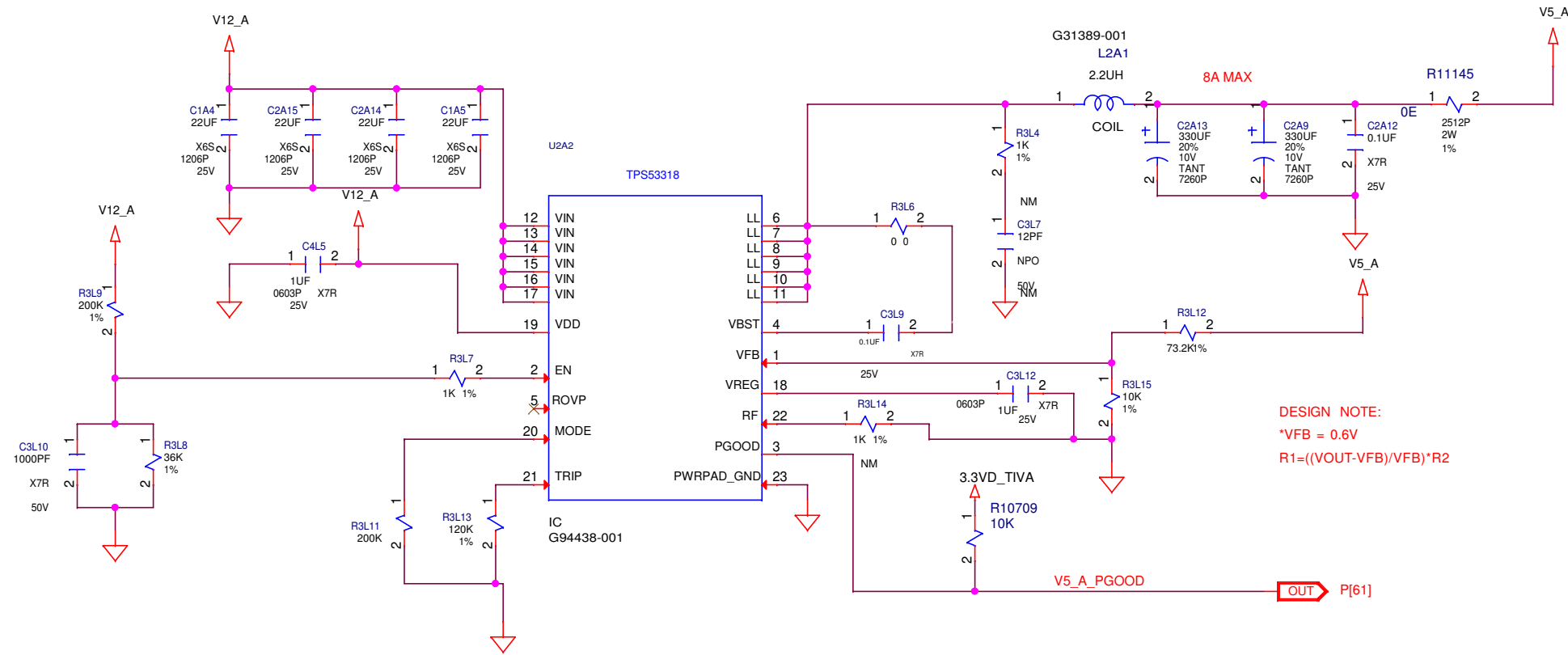
1: SPI MODE


0: LPC MODE

UNLESS OTHERWISE SPECIFIED:  
RESISTORS ARE 0402 PACKAGE, POWER RATING < 0.5W & TOLERANCE > 1%  
CAPACITORS ARE 0402 PACKAGE & TOLERANCE OF 10%



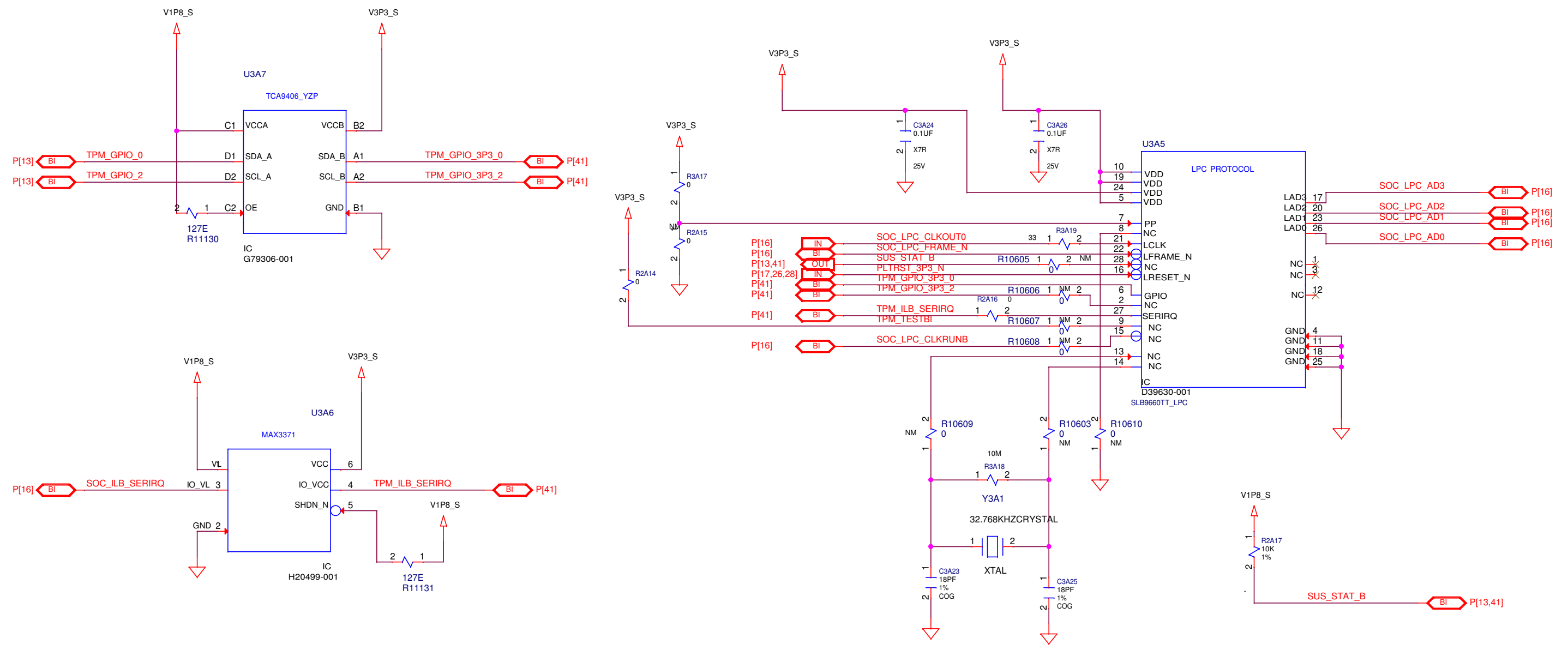
UNLESS OTHERWISE SPECIFIED:  
RESISTORS ARE 0402 PACKAGE, POWER RATING < 0.5W & TOLERANCE > 1%  
CAPACITORS ARE 0402 PACKAGE & TOLERANCE OF 10%

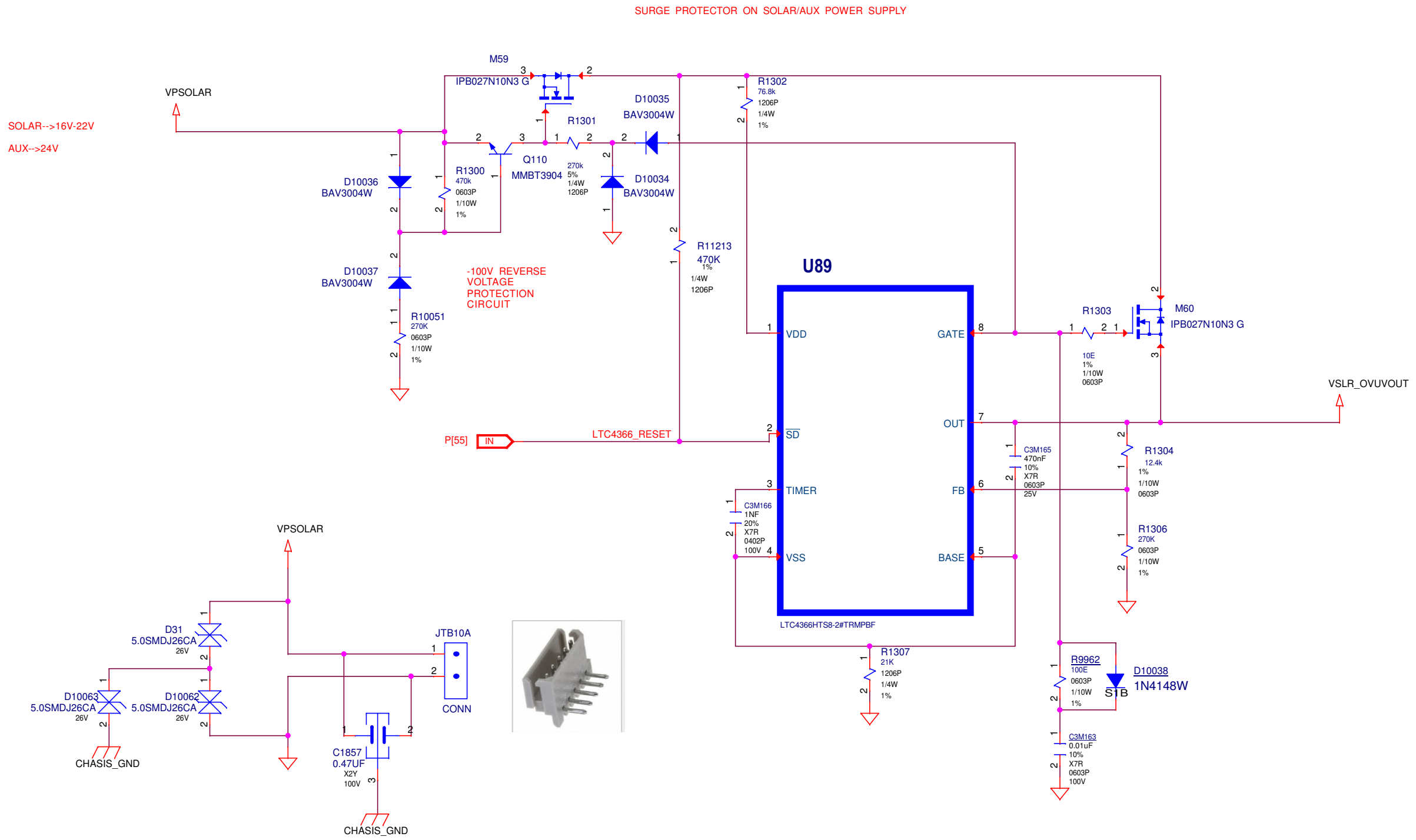


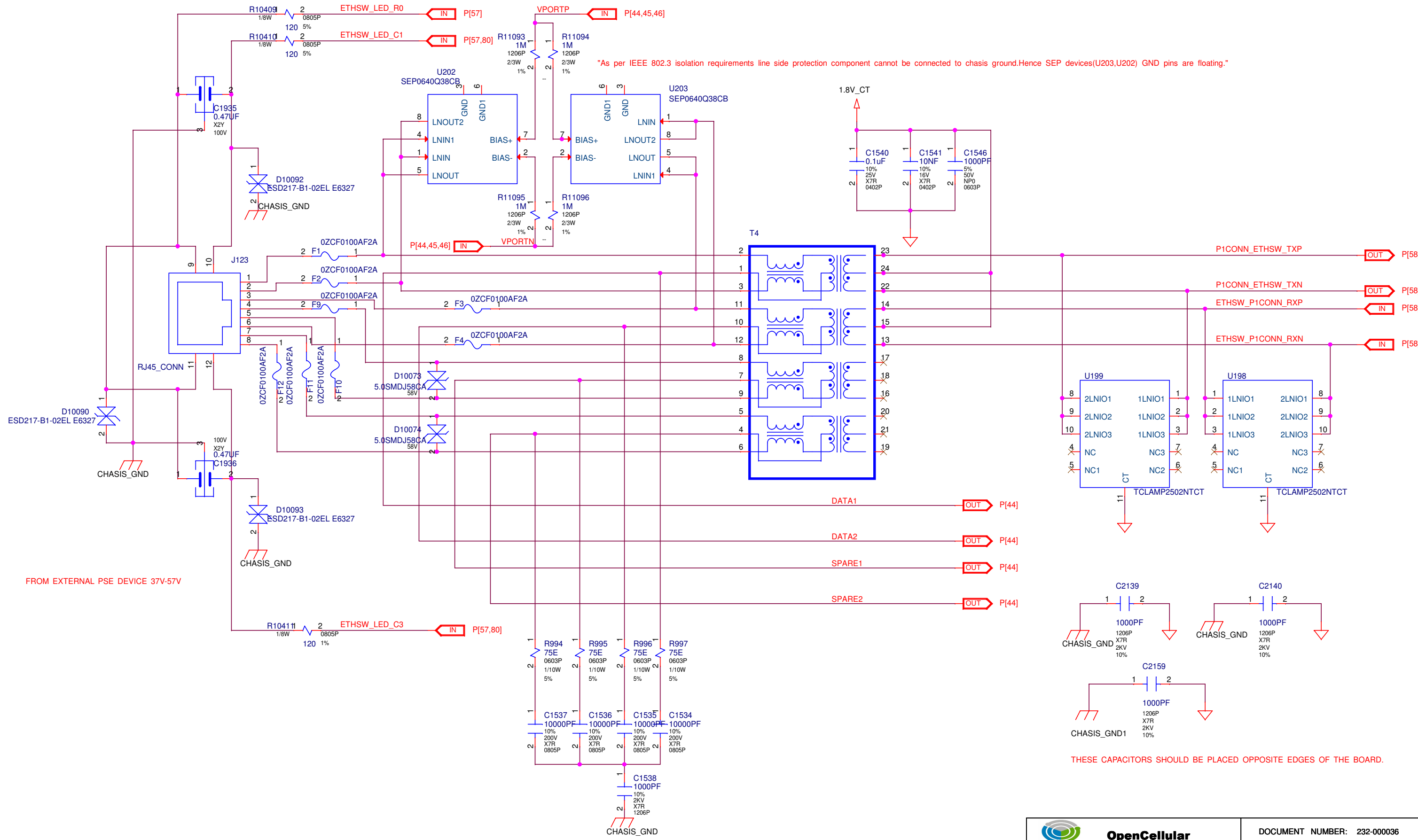
 <b>OpenCellular</b>	DOCUMENT NUMBER: 232-000036	
	TITLE: POWER	LIFE 3



UNLESS OTHERWISE SPECIFIED:  
RESISTORS ARE 0402 PACKAGE, POWER RATING < 0.5W & TOLERANCE > 1%  
CAPACITORS ARE 0402 PACKAGE & TOLERANCE OF 10%




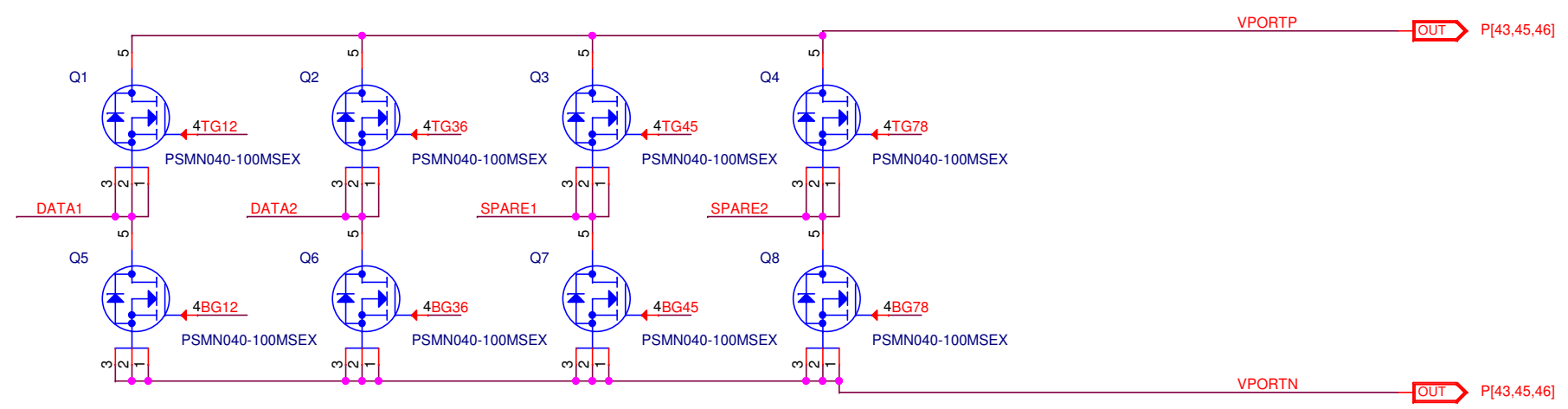
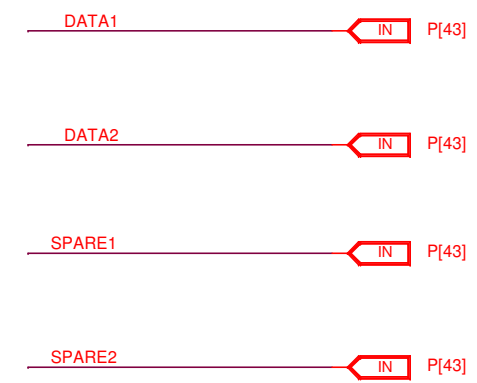
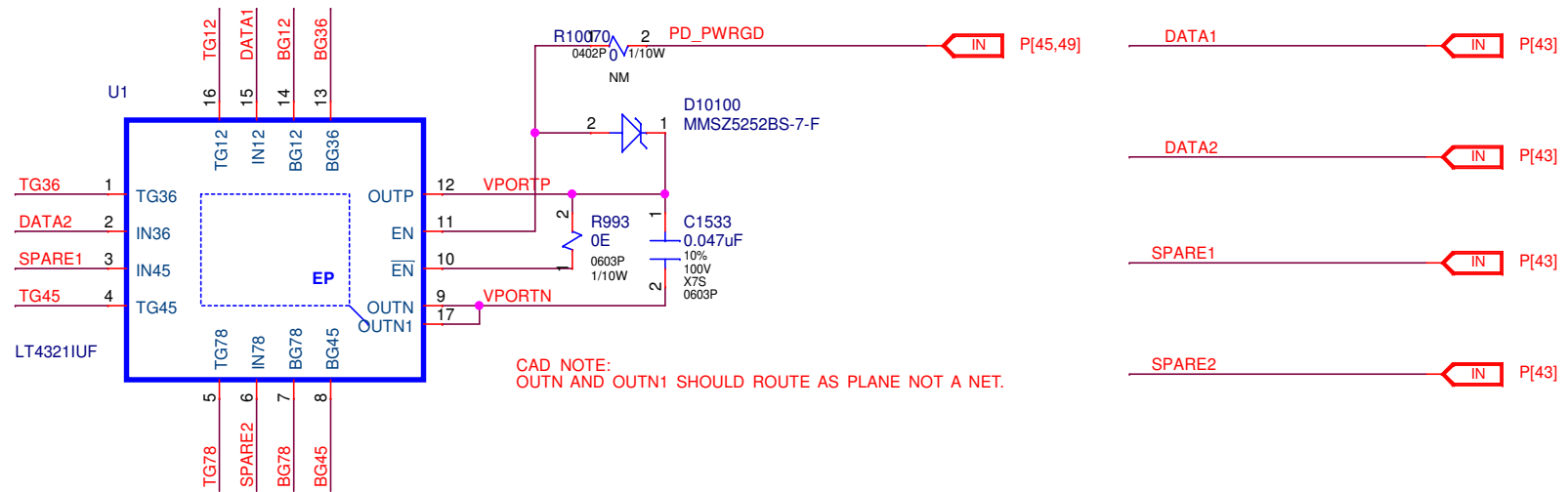


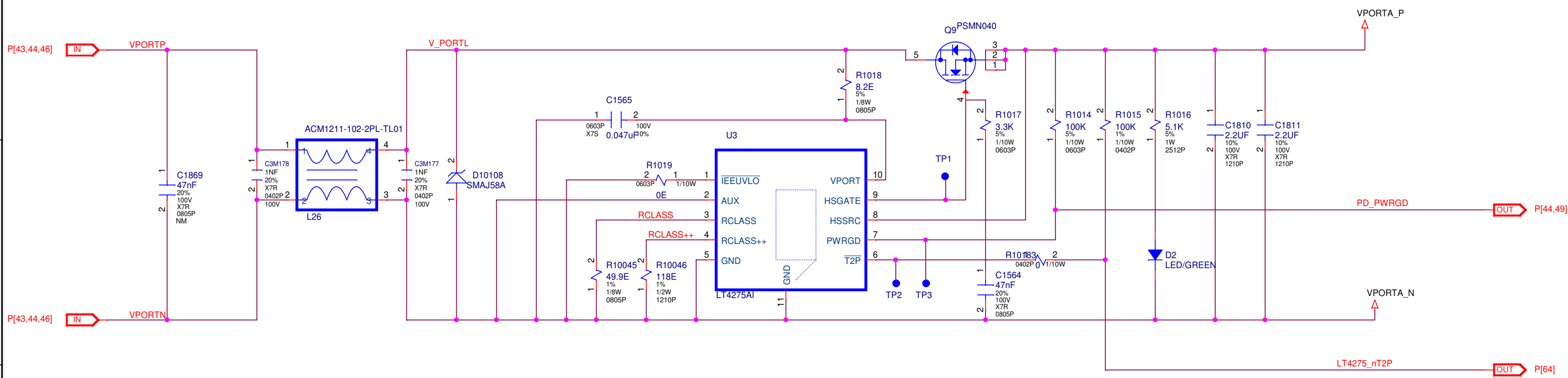


"As per IEEE 802.3 isolation requirements line side protection component cannot be connected to chassis ground.Hence SEP devices(U203,U202) GND pins are floating."

THESE CAPACITORS SHOULD BE PLACED OPPOSITE EDGES OF THE BOARD.

 <b>OpenCellular</b>	DOCUMENT NUMBER: 232-000036	
	TITLE: PORT A RJ45	LIFE 3

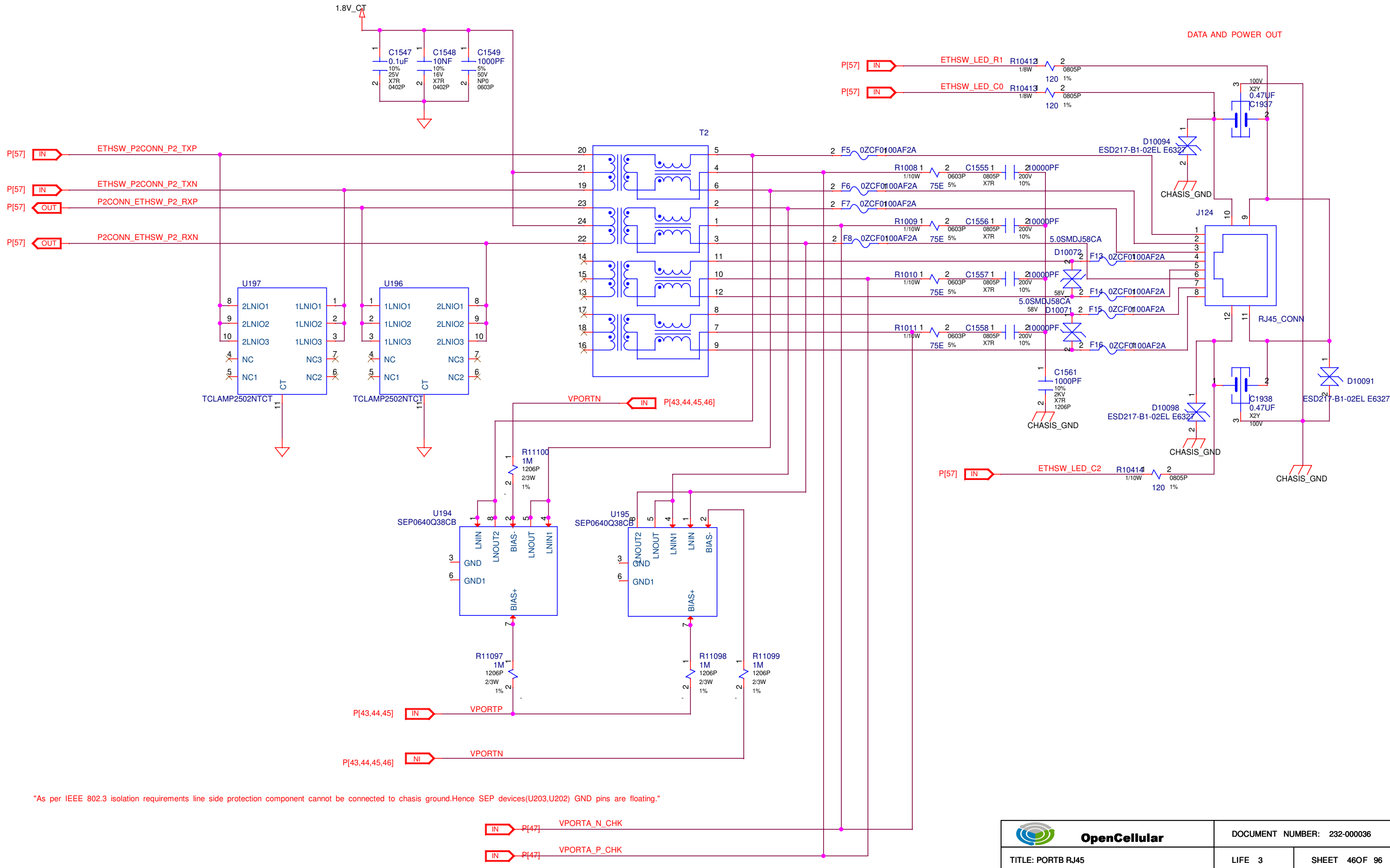




**Table 1. Classification Codes, Power Levels and Resistor Selection**

CLASS	PD POWER AVAILABLE	PD TYPE	NOMINAL CLASS CURRENT	LT4275 GRADE CAPABILITY			RESISTOR	
				A	B	C	R <sub>CLS</sub>	R <sub>CLS++</sub>
0	13W	Type 1	<0.4mA	✓	✓	✓	Open	Open
1	3.84W	Type 1	10.5mA	✓	✓	✓	140Ω	Open
2	6.49W	Type 1	18.5mA	✓	✓	✓	76.8Ω	Open
3	13W	Type 1	28mA	✓	✓	✓	49.9Ω	Open
4	25.5W	Type 2	40mA	✓	✓		34.8Ω	Open
4*	38.7W	LTPoE++	40mA	✓			Open	34.8Ω
4*	52.7W	LTPoE++	40mA	✓			140Ω	46.4Ω
4*	70W	LTPoE++	40mA	✓			76.8Ω	64.9Ω
4*	90W	LTPoE++	40mA	✓			49.9Ω	118Ω

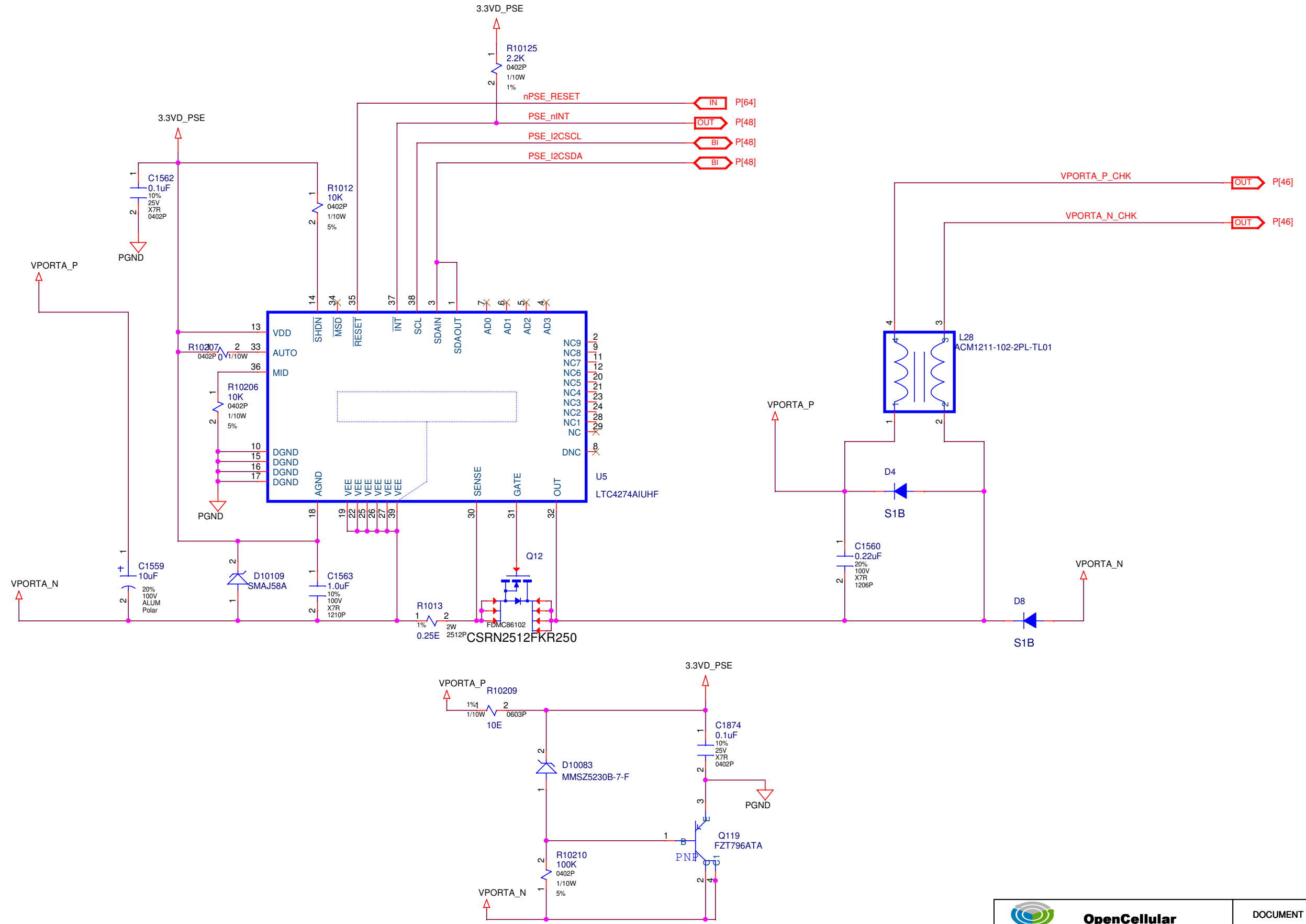
\*An LTPoE++ PD will be classified as class 4 by an IEEE 802.3 compliant PSE.




\*As per IEEE 802.3 isolation requirements line side protection component cannot be connected to chassis ground.Hence SEP devices(U203,U202) GND pins are floating.\*

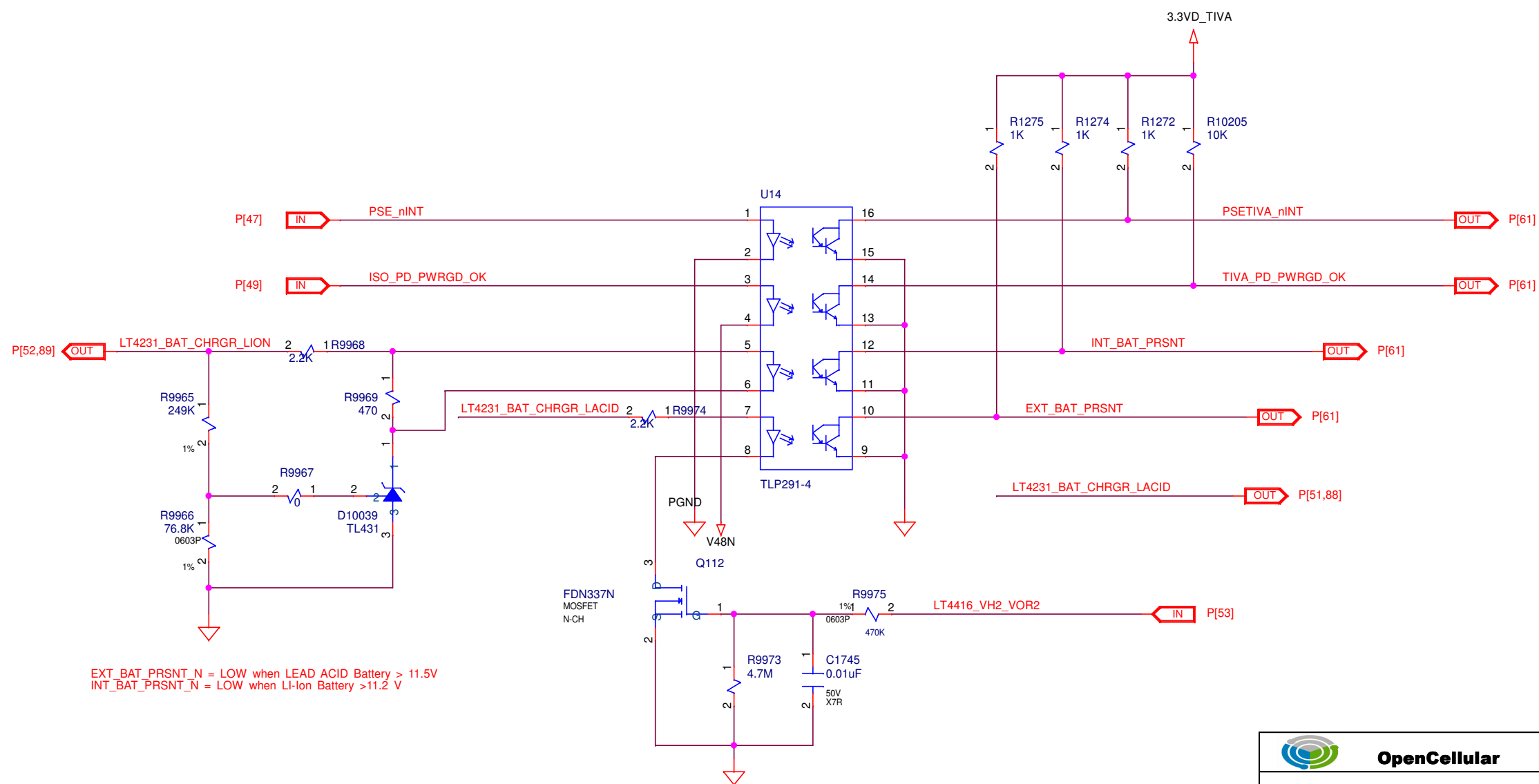
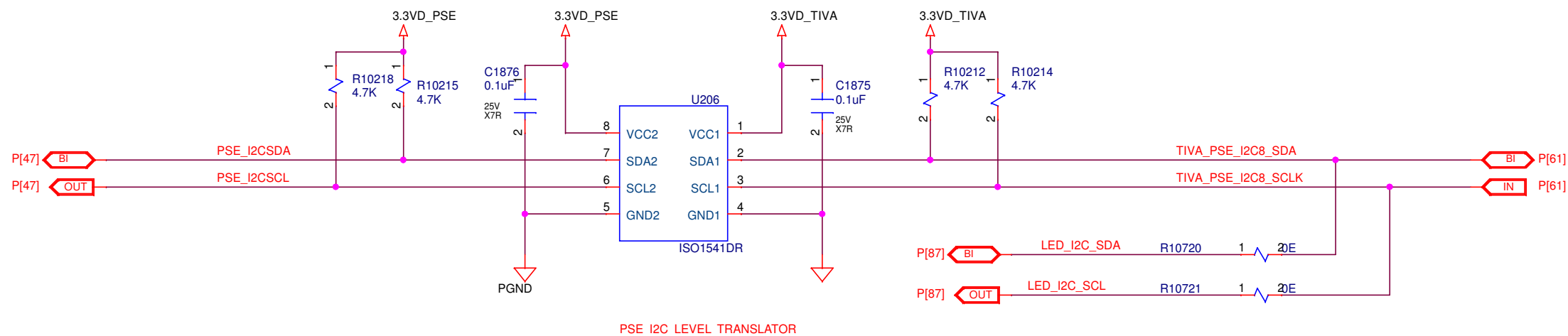
	DOCUMENT NUMBER: 232-000036	
	TITLE: PORTB RJ45	LIFE 3


MAIN PS  
INPUTS  
(55V TO 57V)



 <b>OpenCellular</b>	DOCUMENT NUMBER: 232-000036	
	TITLE: POE PSE	LIFE 3

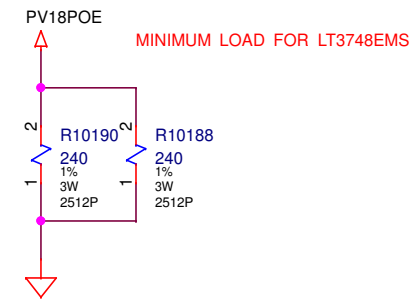
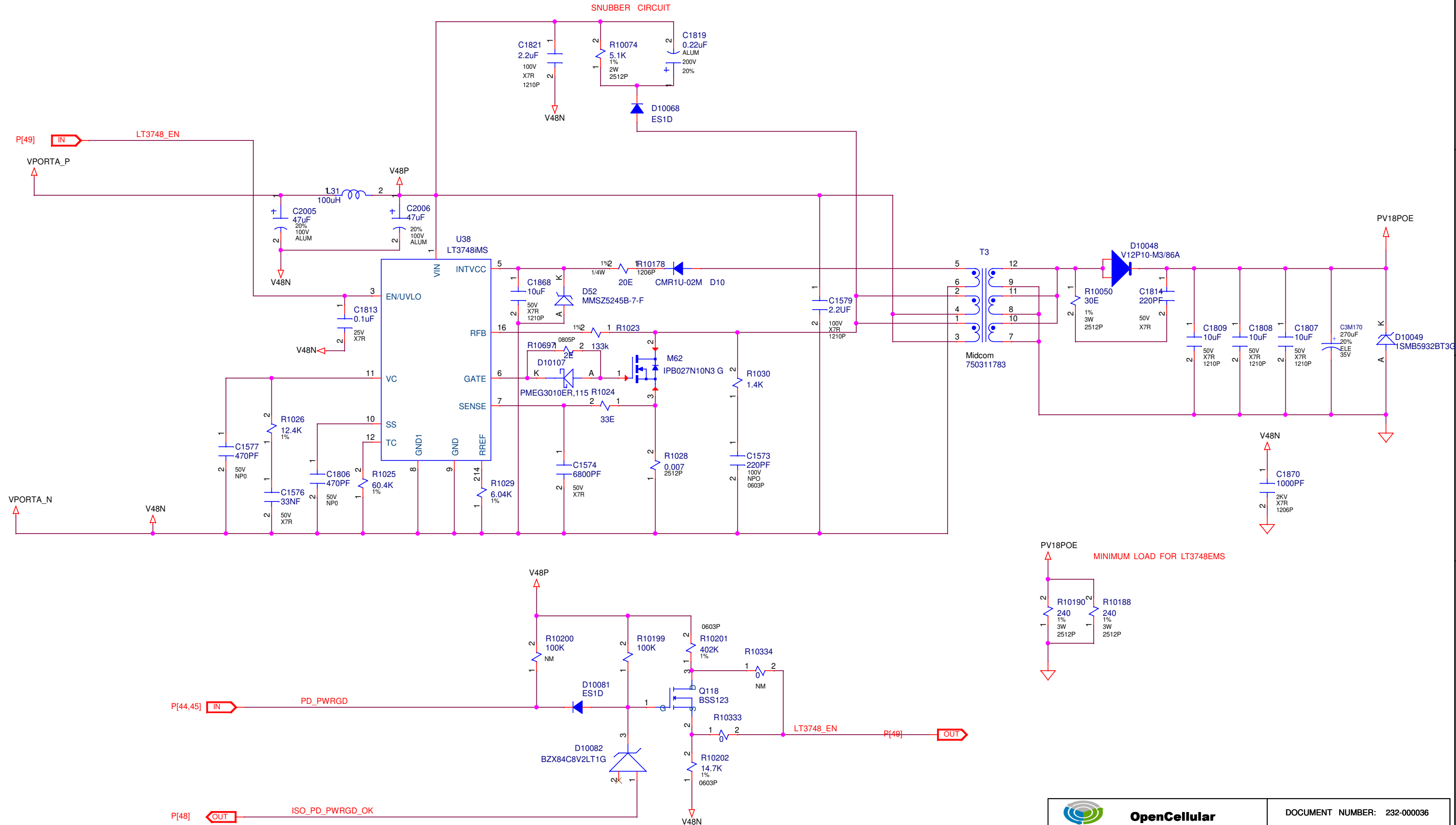
UNLESS OTHERWISE SPECIFIED:  
 RESISTORS ARE 0402 PACKAGE, POWER RATING < 0.5W & TOLERANCE > 1%  
 CAPACITORS ARE 0402 PACKAGE & TOLERANCE OF 10%



 <b>OpenCellular</b>	DOCUMENT NUMBER: 232-000036	
	TITLE: PSE I2C ISO	LIFE 3

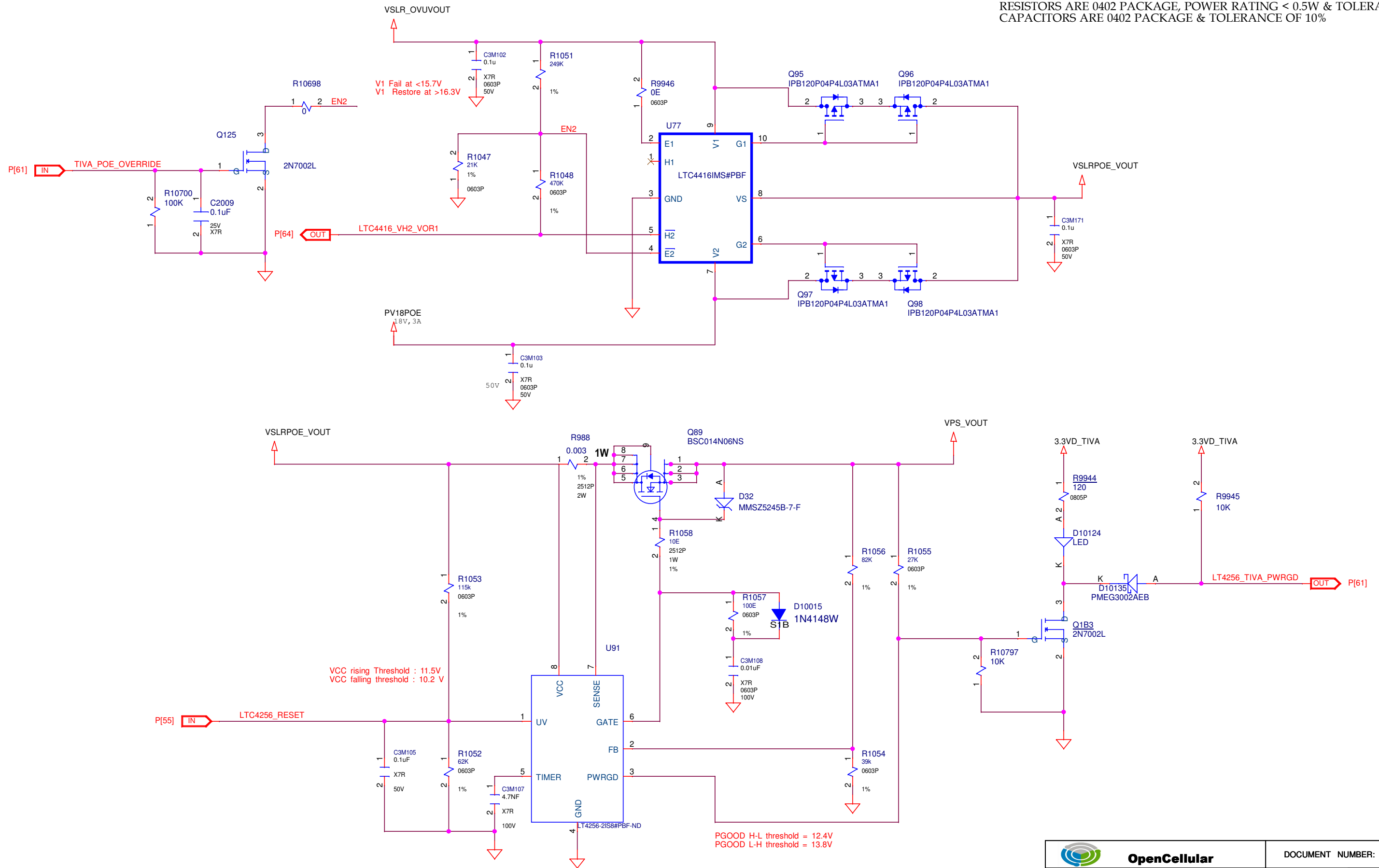


UNLESS OTHERWISE SPECIFIED:  
 RESISTORS ARE 0402 PACKAGE, POWER RATING < 0.5W & TOLERANCE > 1%  
 CAPACITORS ARE 0402 PACKAGE & TOLERANCE OF 10%

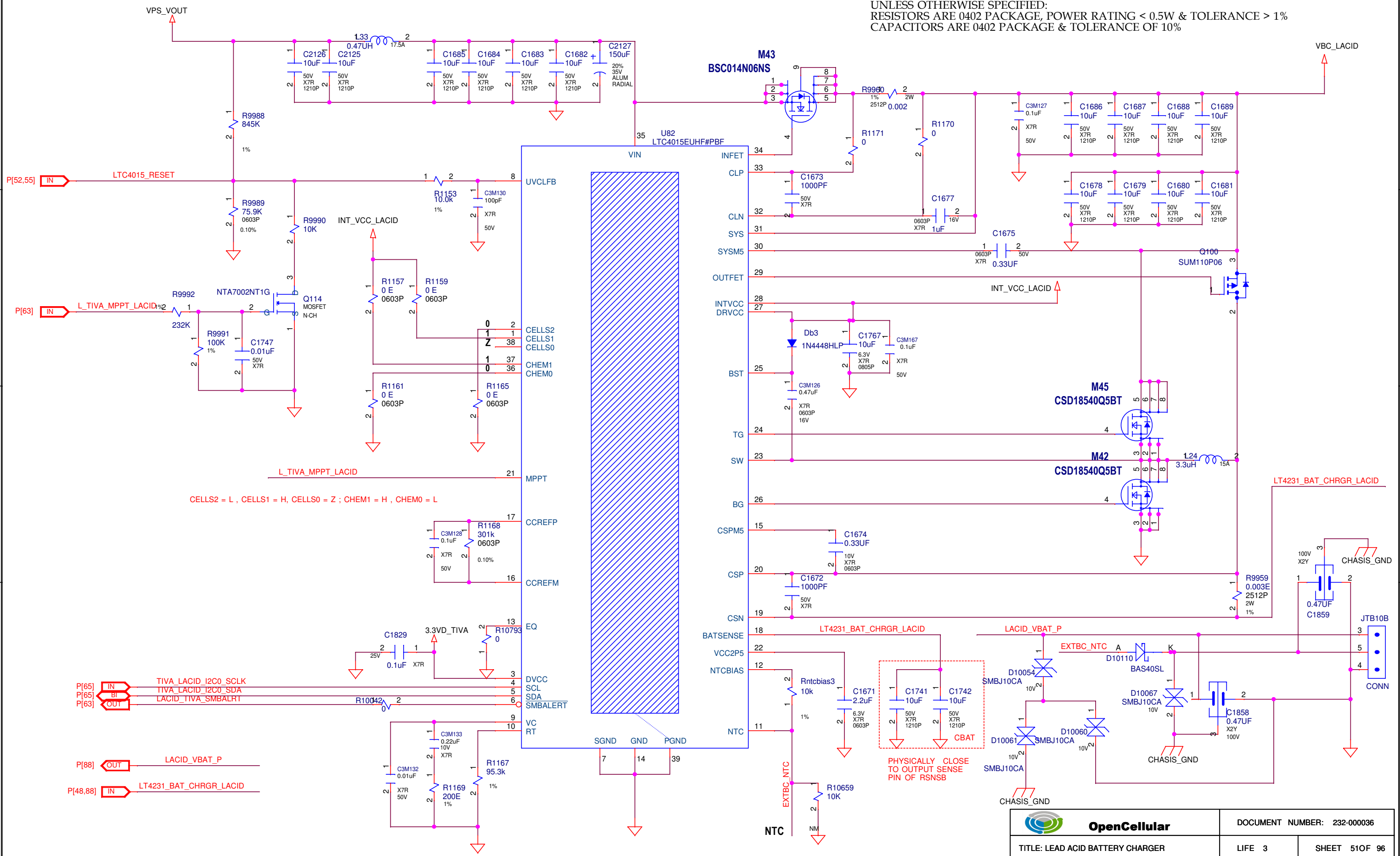


	DOCUMENT NUMBER: 232-000036	
	TITLE: 48V TO 18V ISOLATED CONVERTER	LIFE 3

UNLESS OTHERWISE SPECIFIED:  
 RESISTORS ARE 0402 PACKAGE, POWER RATING < 0.5W & TOLERANCE > 1%  
 CAPACITORS ARE 0402 PACKAGE & TOLERANCE OF 10%



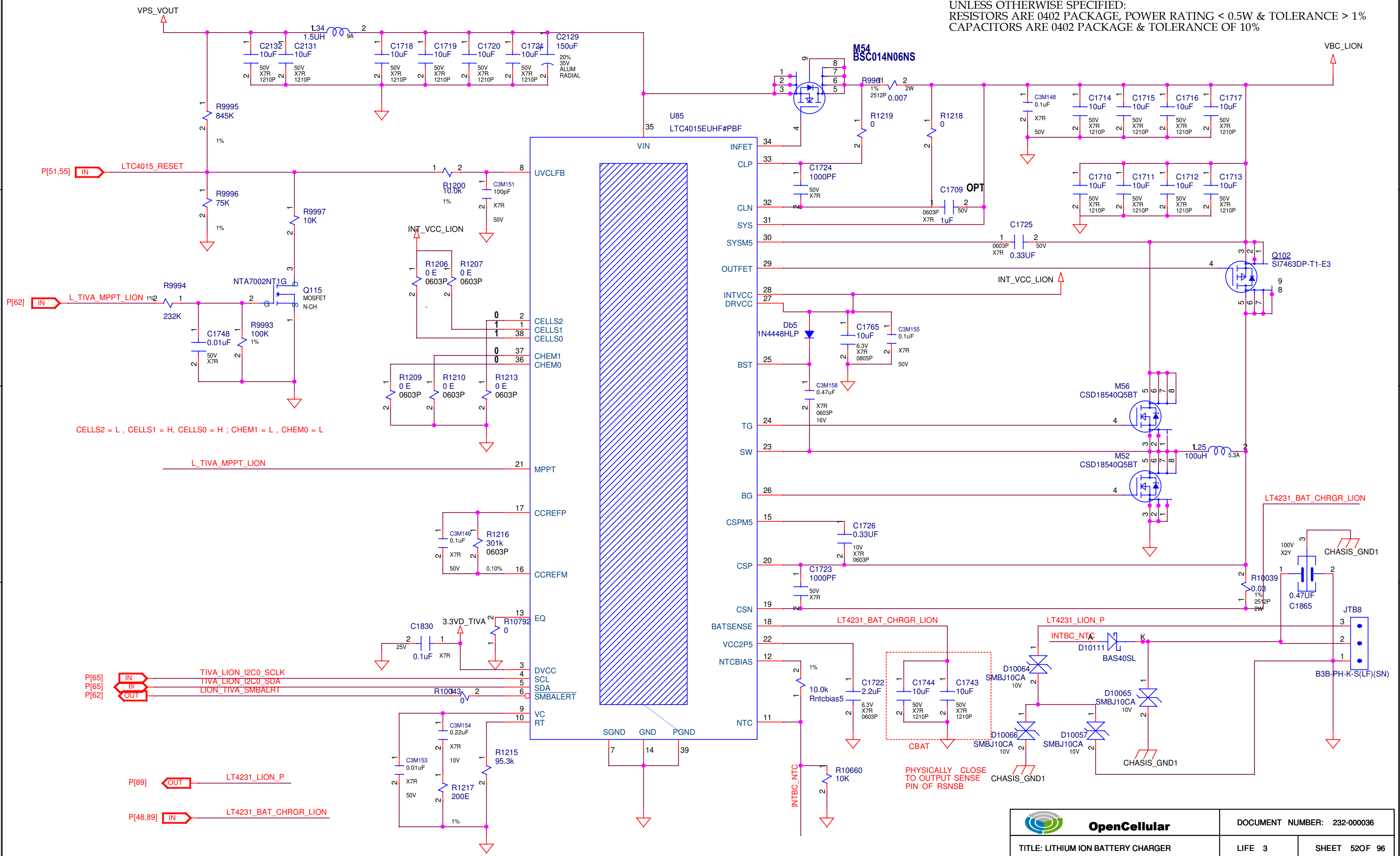
UNLESS OTHERWISE SPECIFIED:  
 RESISTORS ARE 0402 PACKAGE, POWER RATING < 0.5W & TOLERANCE > 1%  
 CAPACITORS ARE 0402 PACKAGE & TOLERANCE OF 10%



CELLS2 = L , CELLS1 = H , CELLS0 = Z ; CHEM1 = H , CHEM0 = L

PHYSICALLY CLOSE TO OUTPUT SENSE PIN OF RSNSB

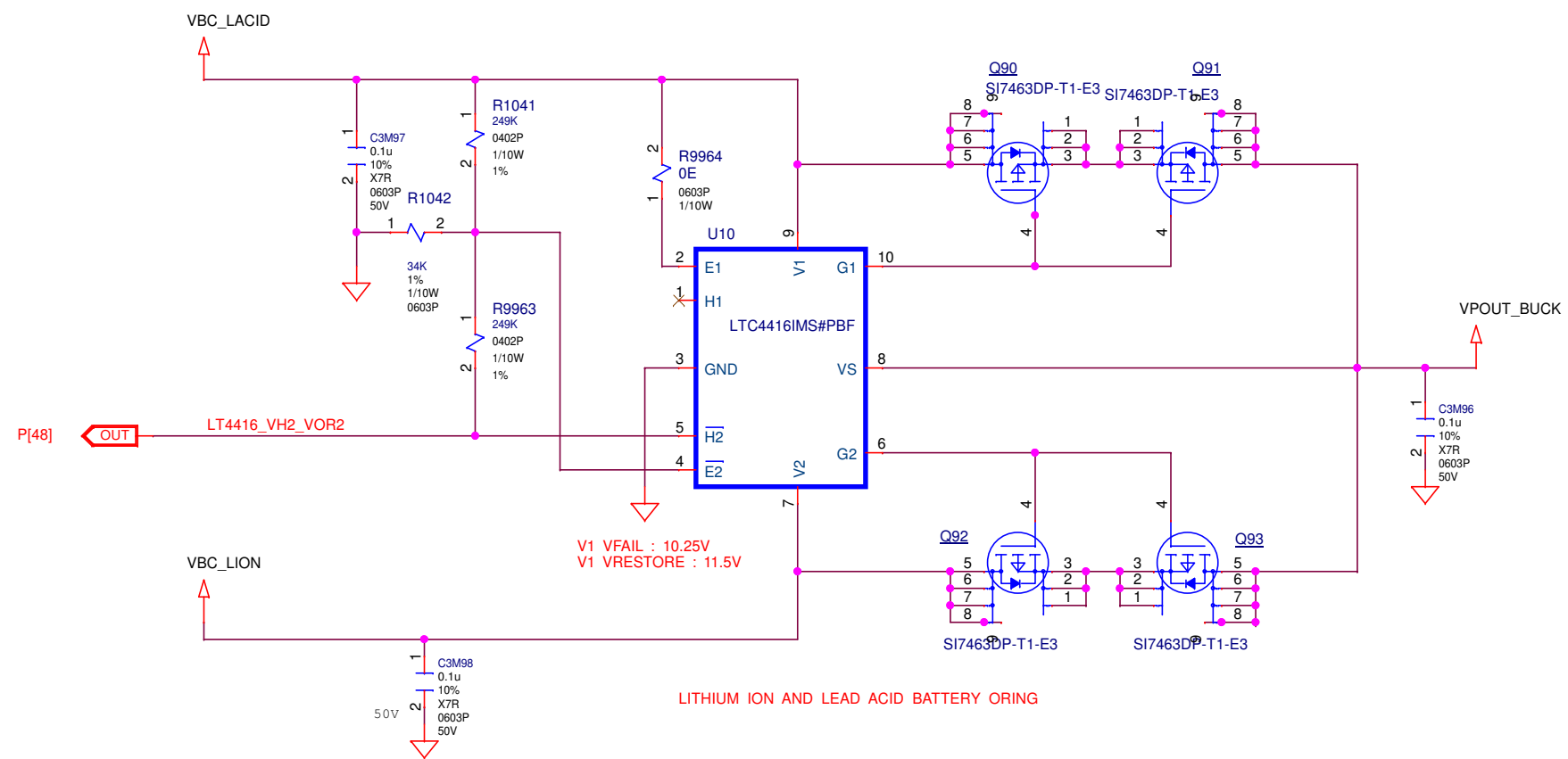
UNLESS OTHERWISE SPECIFIED:  
 RESISTORS ARE 0402 PACKAGE, POWER RATING < 0.5W & TOLERANCE > 1%  
 CAPACITORS ARE 0402 PACKAGE & TOLERANCE OF 10%




CELLS2 = L , CELLS1 = H, CELLS0 = H ; CHEM1 = L , CHEM0 = L

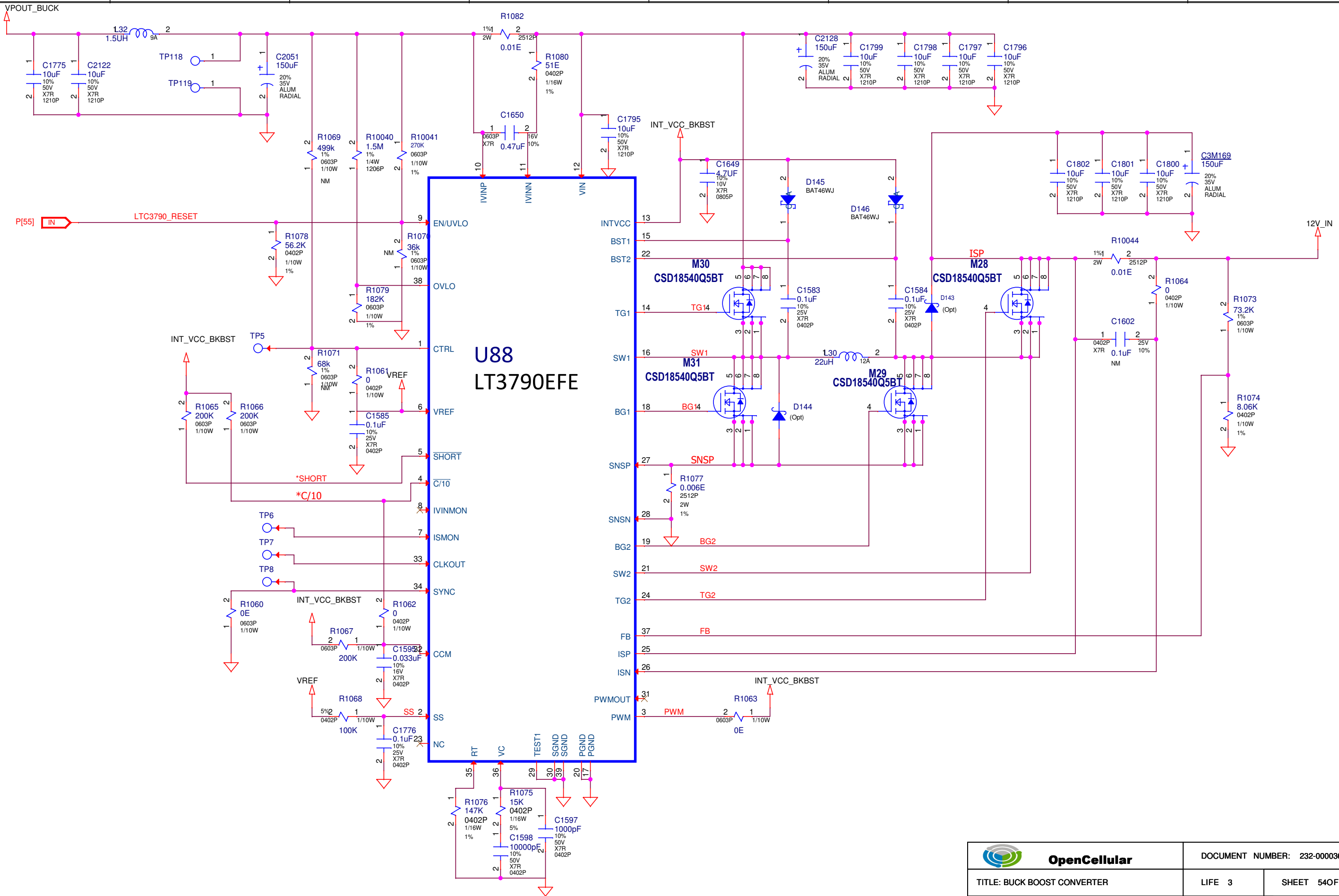
PHYSICALLY CLOSE TO OUTPUT SENSE PIN OF RSNSB


	DOCUMENT NUMBER: 232-000036	
	TITLE: LITHIUM ION BATTERY CHARGER	LIFE 3



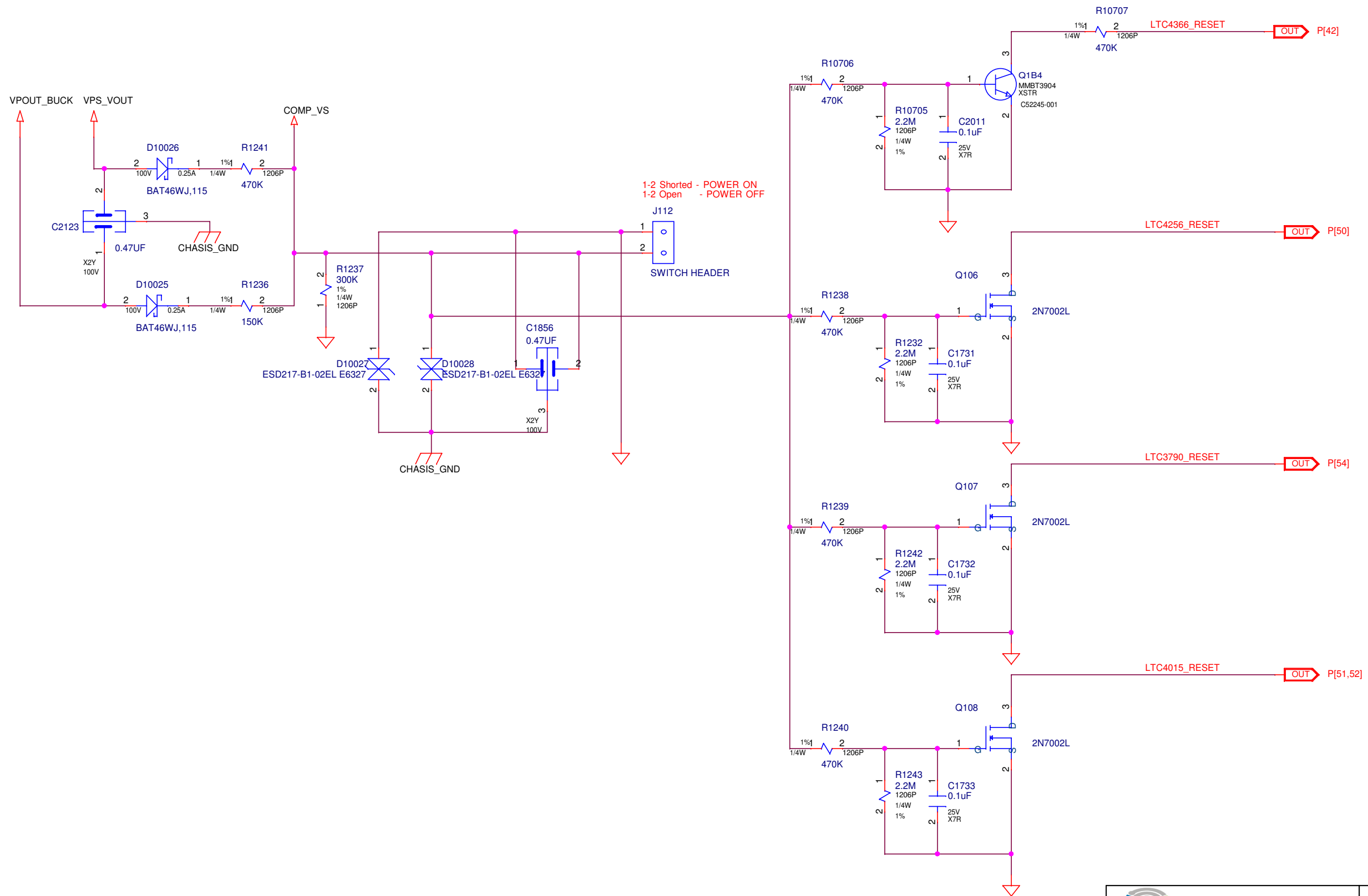
 <b>OpenCellular</b>	DOCUMENT NUMBER: 232-000036	
	LIFE 3	SHEET 53OF 96


TITLE: POWER ORING



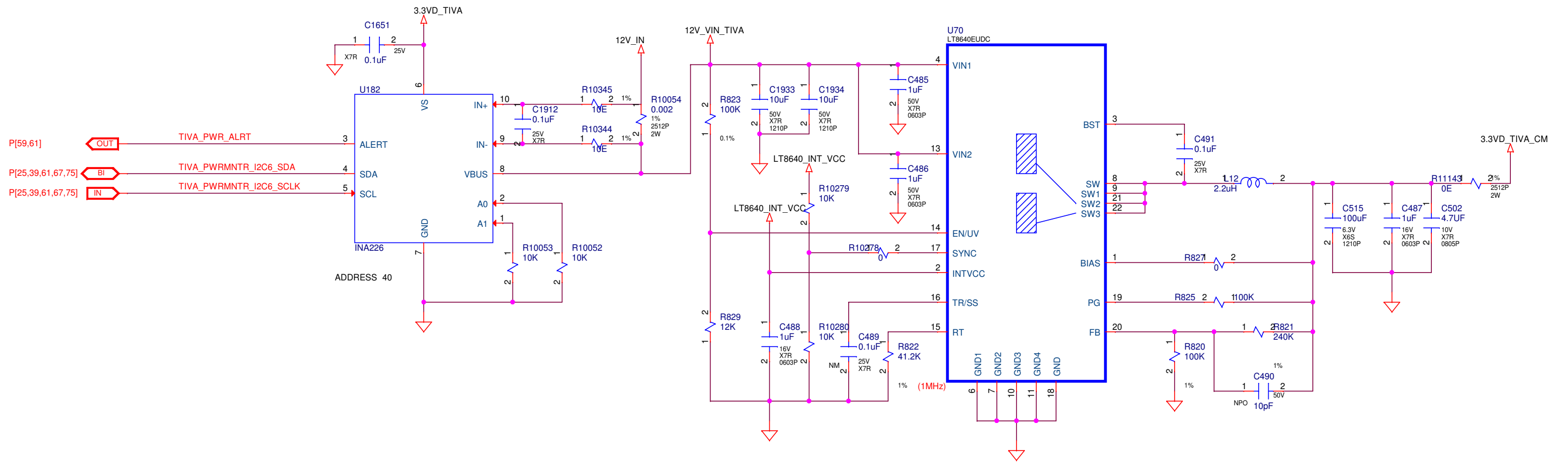
 <b>OpenCellular</b>	DOCUMENT NUMBER: 232-000036	
	TITLE: BUCK BOOST CONVERTER	LIFE 3


UNLESS OTHERWISE SPECIFIED:  
 RESISTORS ARE 0402 PACKAGE, POWER RATING < 0.5W & TOLERANCE > 1%  
 CAPACITORS ARE 0402 PACKAGE & TOLERANCE OF 10%



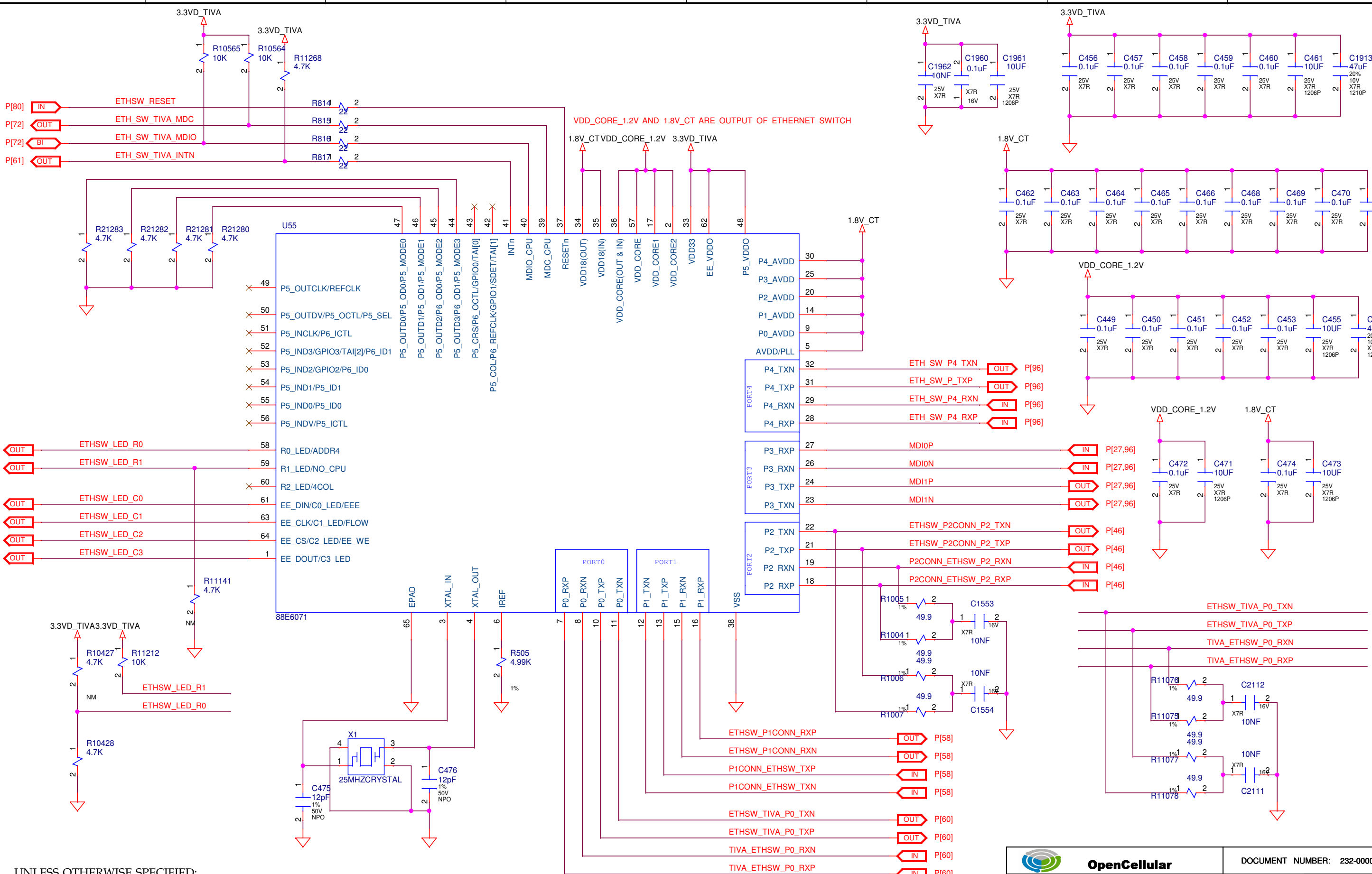
 <b>OpenCellular</b>	DOCUMENT NUMBER: 232-000036	
	TITLE: POWER SWITCH	LIFE 3

UNLESS OTHERWISE SPECIFIED:  
 RESISTORS ARE 0402 PACKAGE, POWER RATING < 0.5W & TOLERANCE > 1%  
 CAPACITORS ARE 0402 PACKAGE & TOLERANCE OF 10%



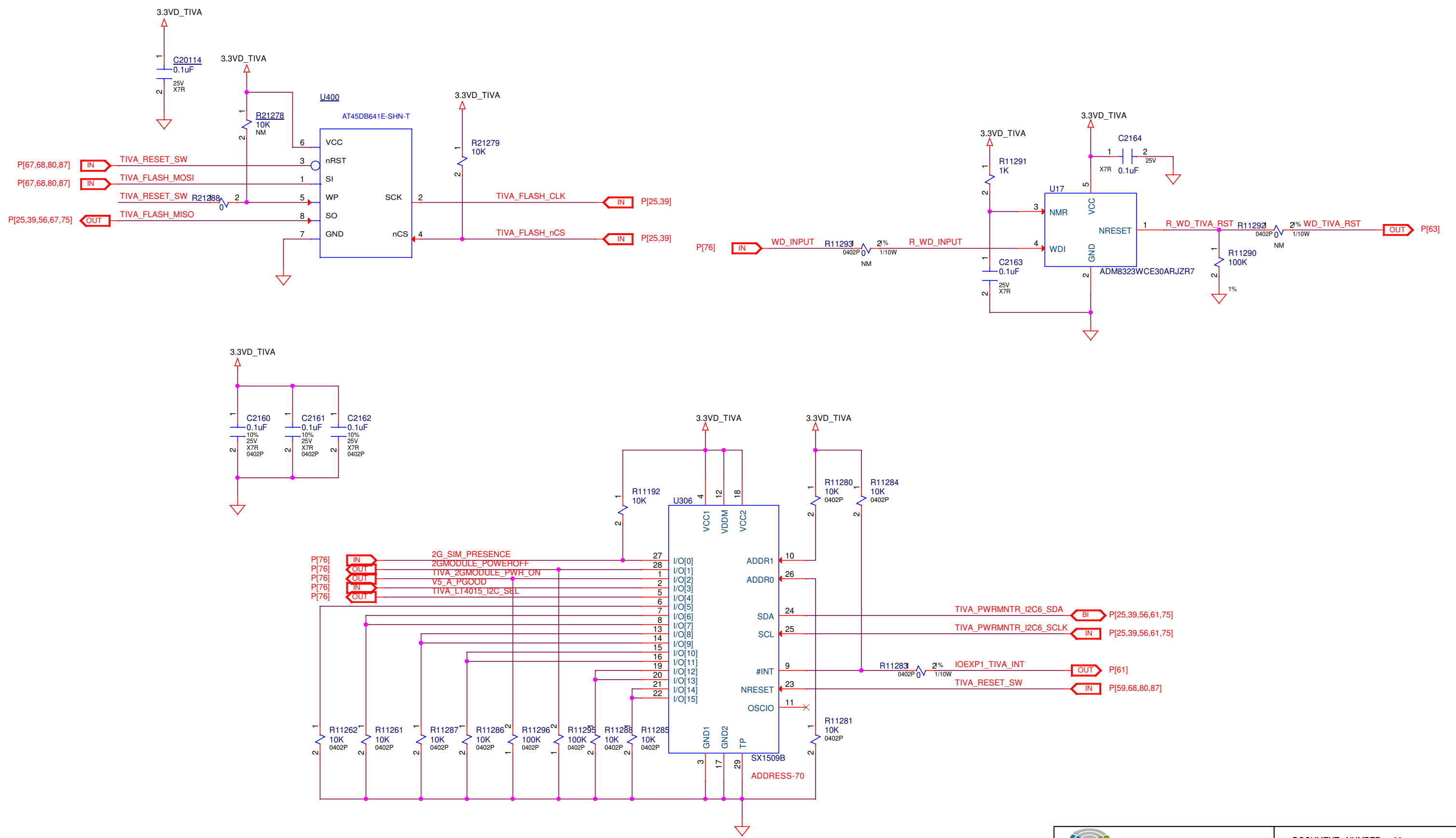
 <b>OpenCellular</b>	DOCUMENT NUMBER: 232-000036	
	TITLE: DC-DC CONVERTER	LIFE 3



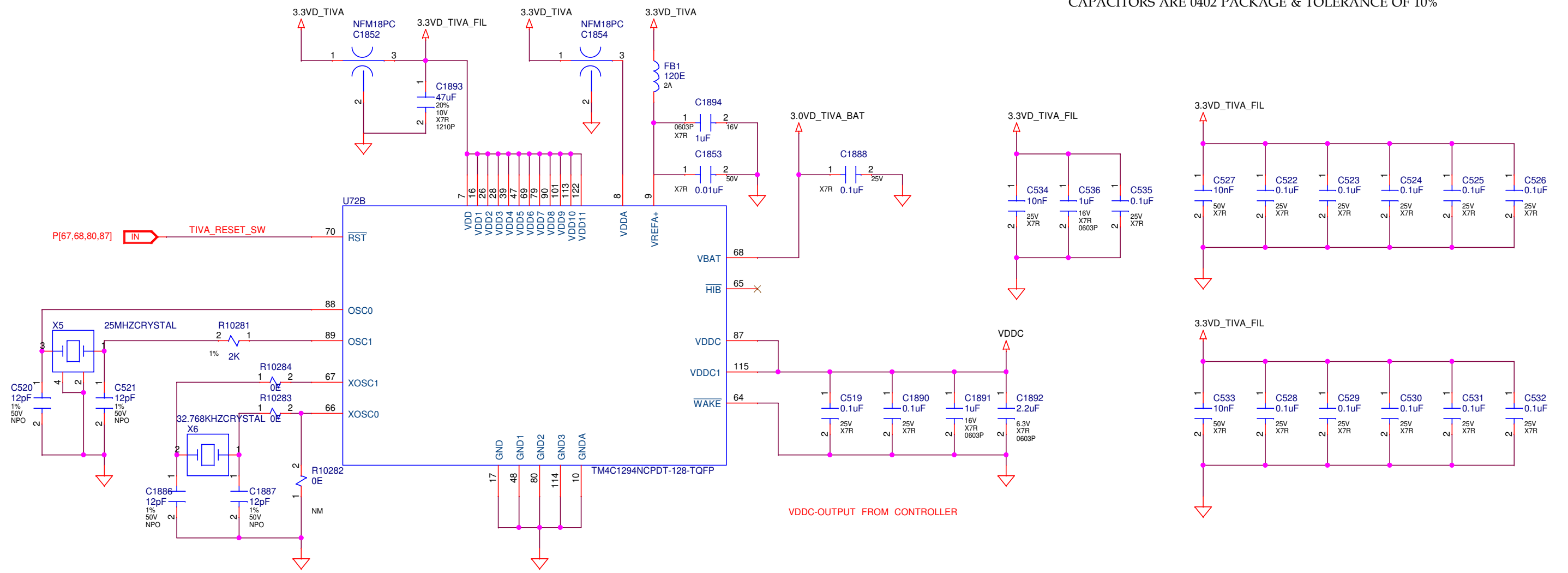


UNLESS OTHERWISE SPECIFIED:  
 RESISTORS ARE 0402 PACKAGE, POWER RATING < 0.5W & TOLERANCE > 1%  
 CAPACITORS ARE 0402 PACKAGE & TOLERANCE OF 10%

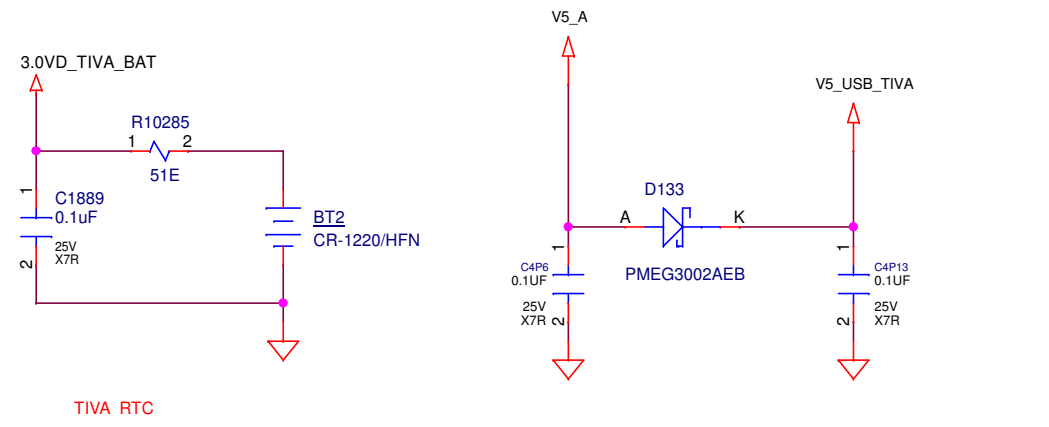
	DOCUMENT NUMBER: 232-000036	
	TITLE: ETHERNET SWITCH	LIFE 3



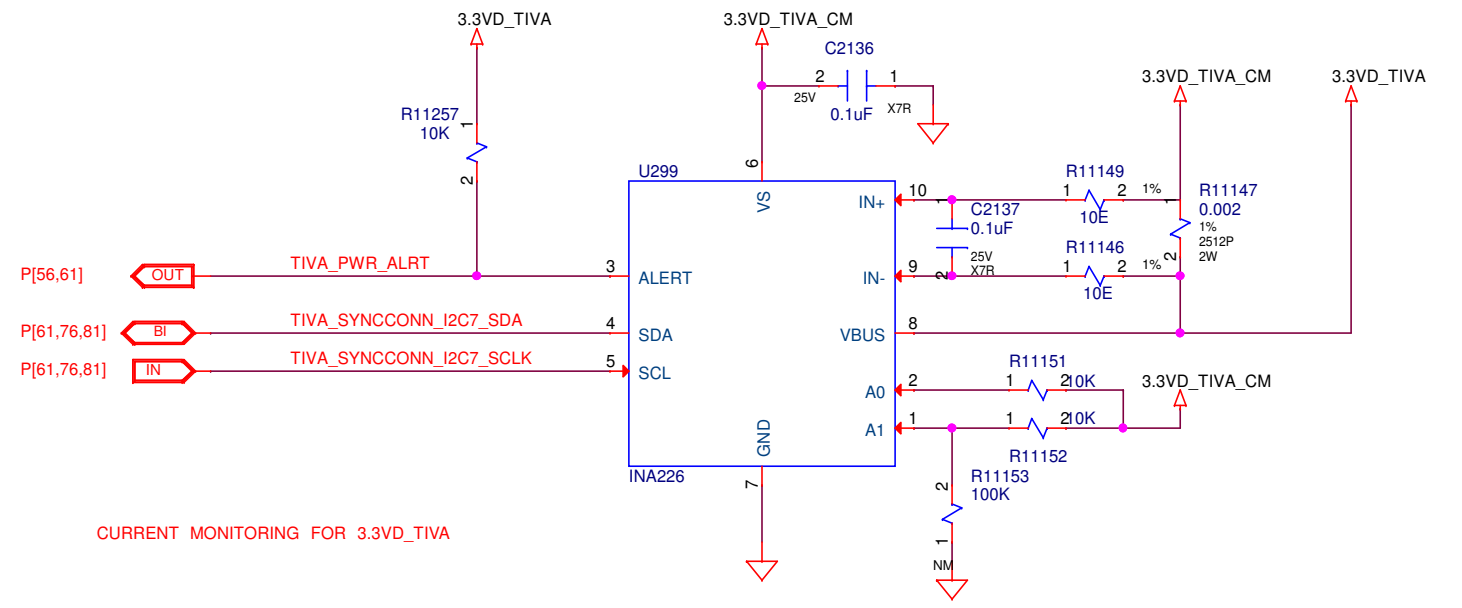
UNLESS OTHERWISE SPECIFIED:  
 RESISTORS ARE 0402 PACKAGE, POWER RATING < 0.5W & TOLERANCE > 1%  
 CAPACITORS ARE 0402 PACKAGE & TOLERANCE OF 10%



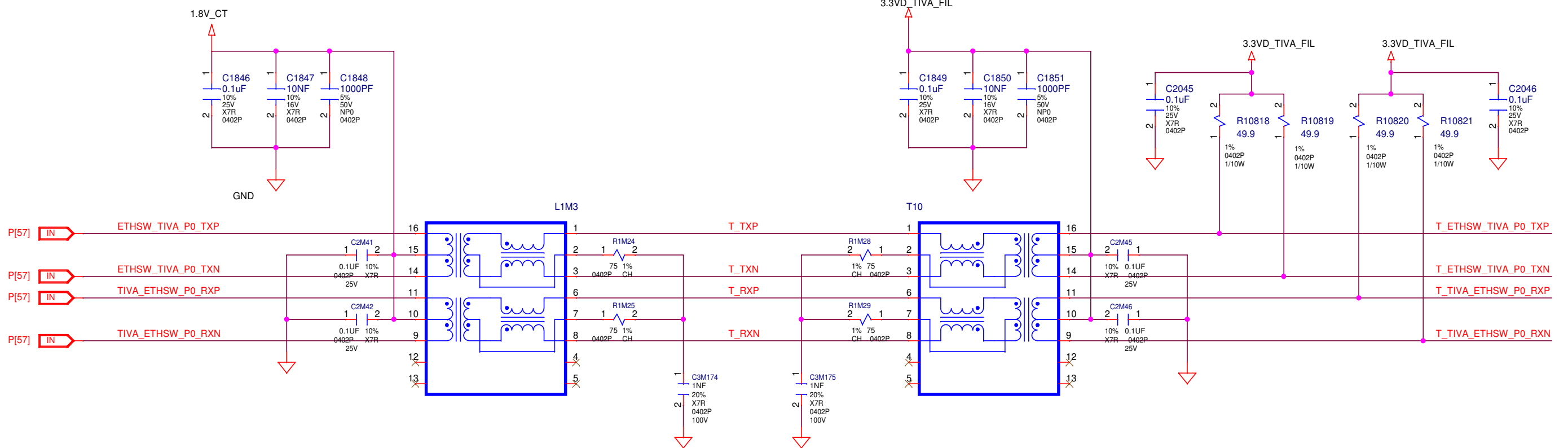
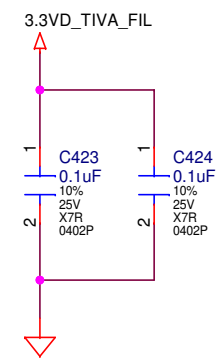
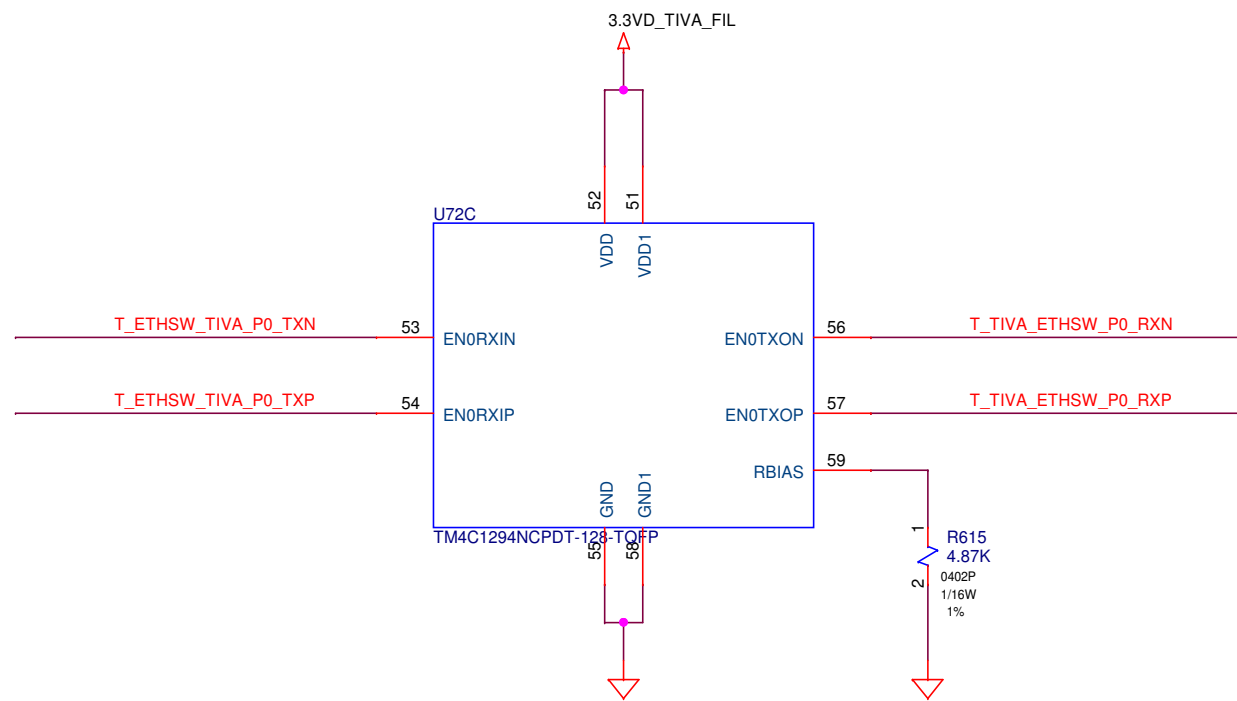
VDDC-OUTPUT FROM CONTROLLER



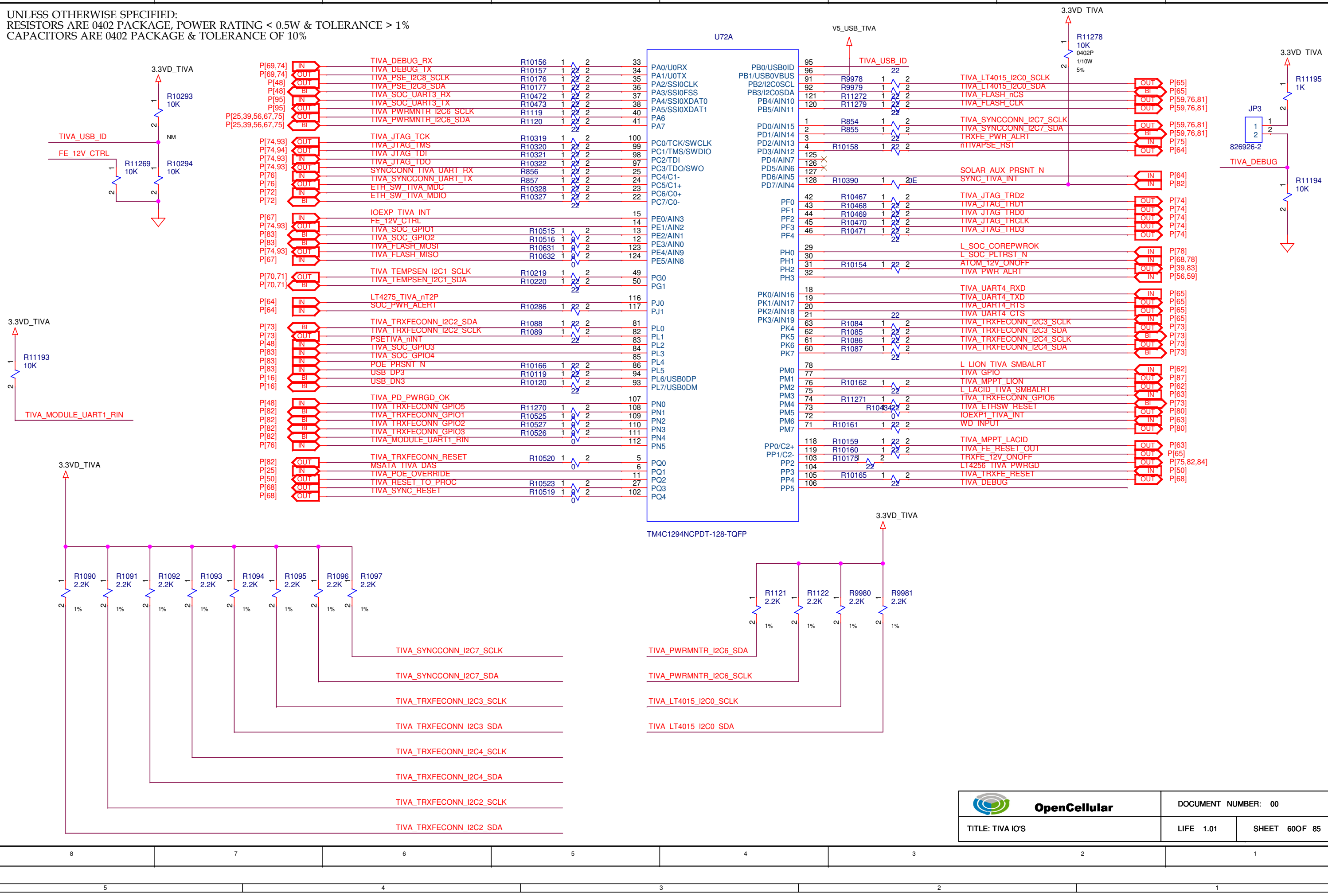
TIVA RTC

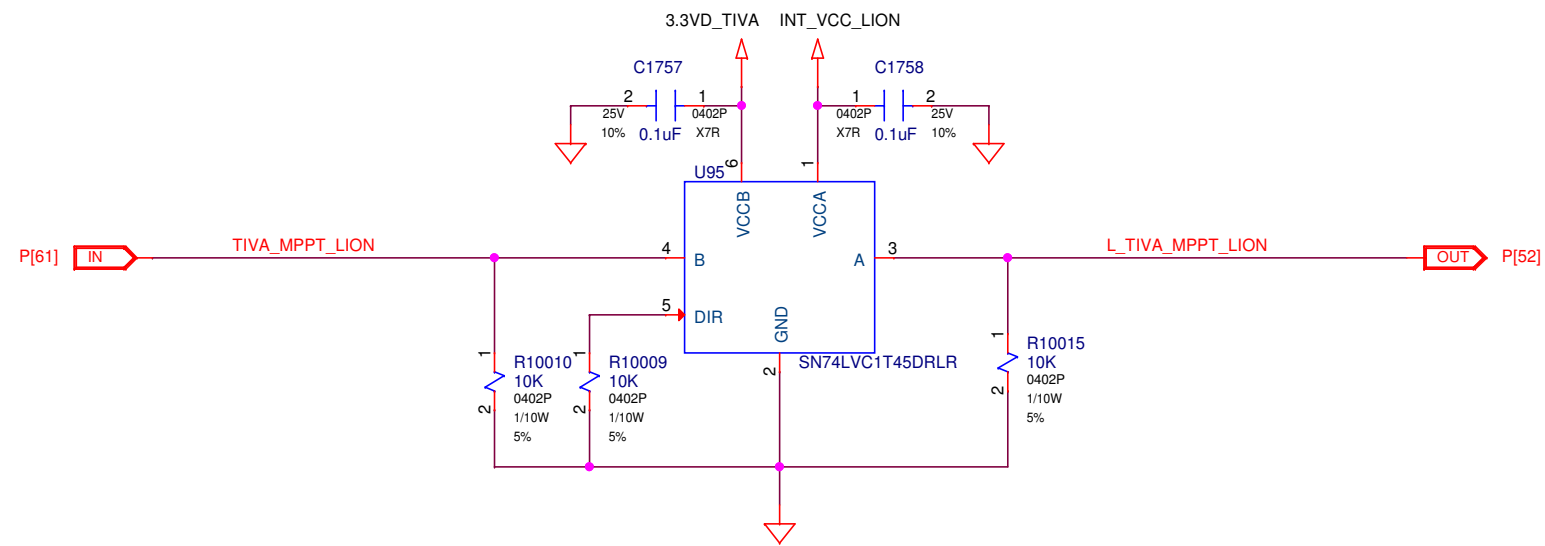
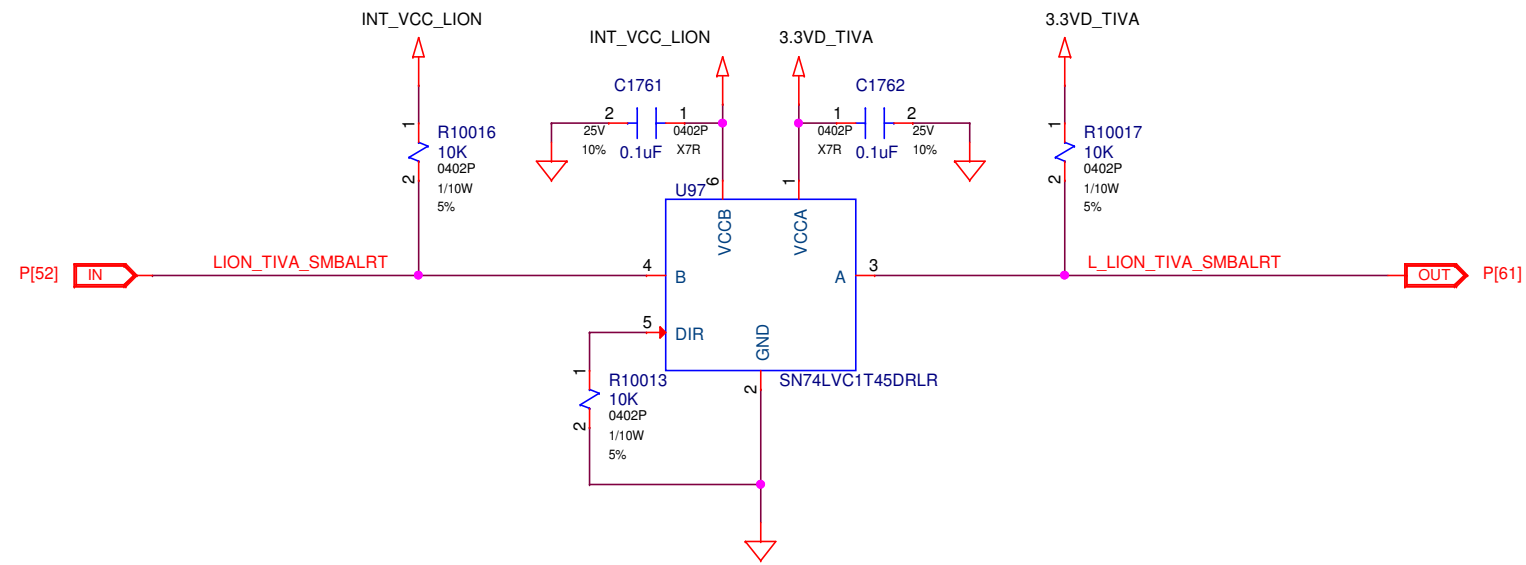


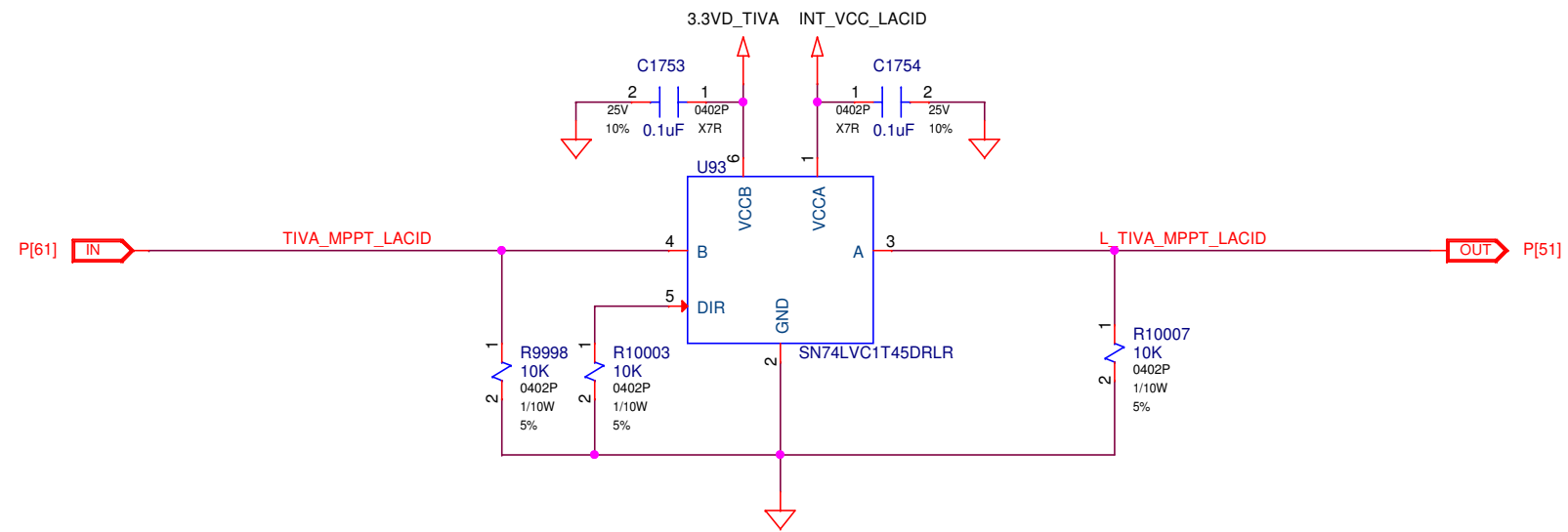
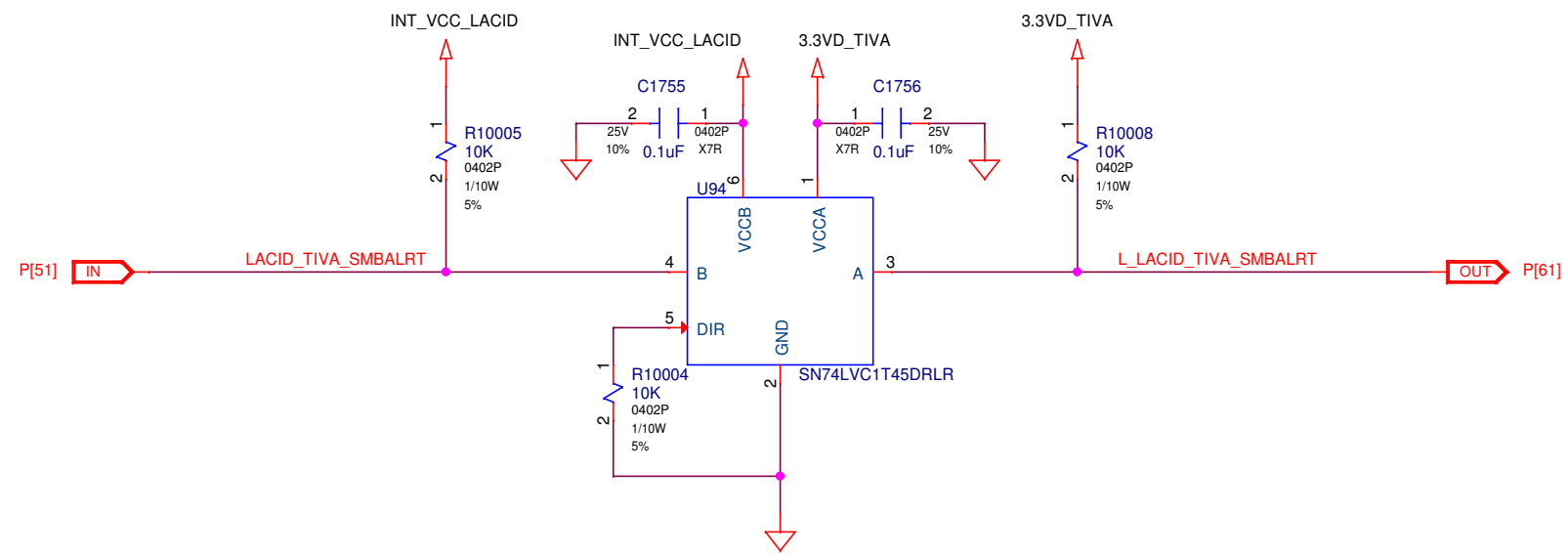
CURRENT MONITORING FOR 3.3VD\_TIVA

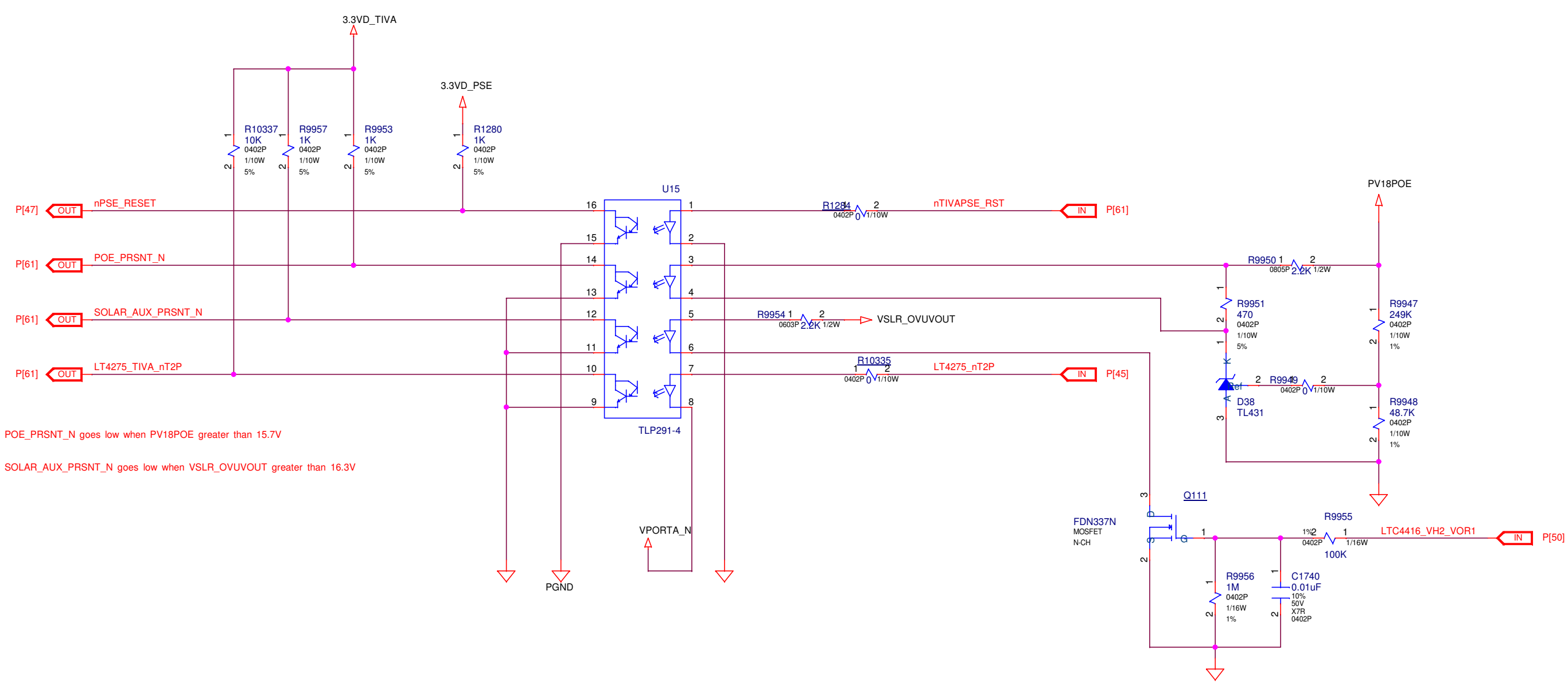


UNLESS OTHERWISE SPECIFIED:  
 RESISTORS ARE 0402 PACKAGE, POWER RATING < 0.5W & TOLERANCE > 1%  
 CAPACITORS ARE 0402 PACKAGE & TOLERANCE OF 10%





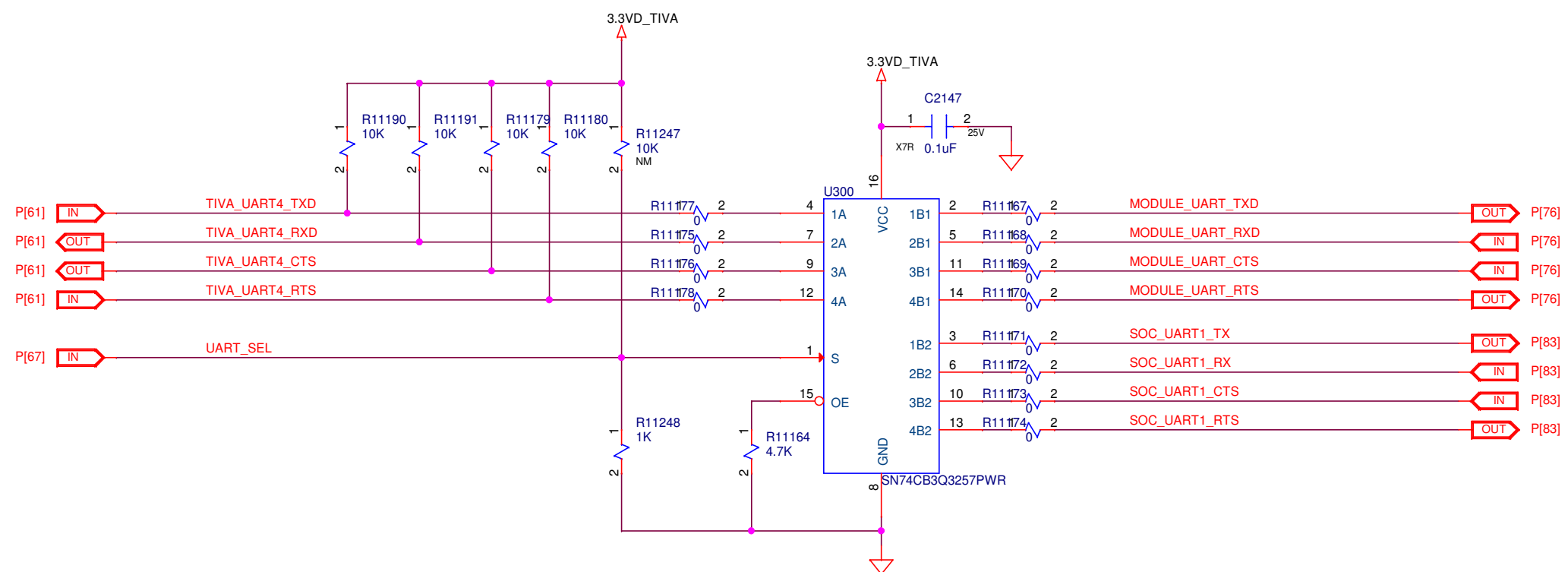
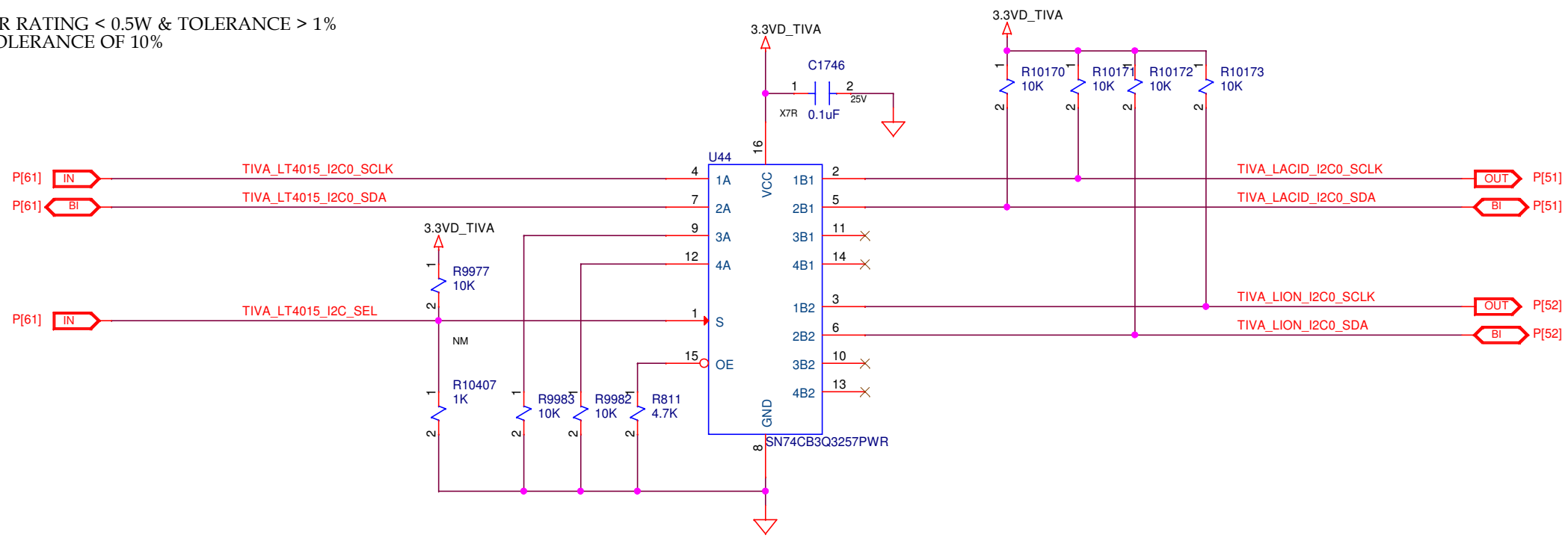




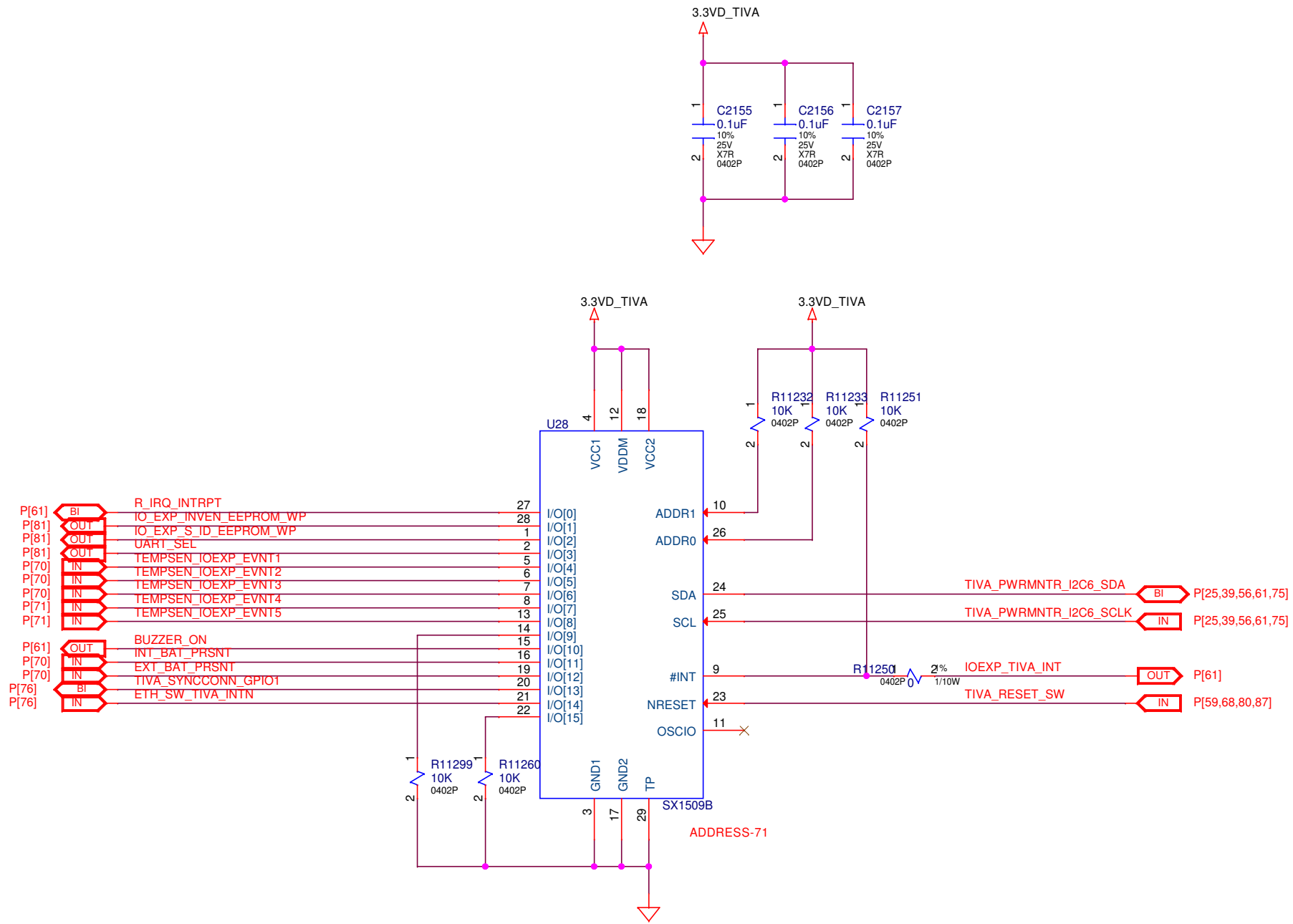
POE\_PRSNT\_N goes low when PV18POE greater than 15.7V  
 SOLAR\_AUX\_PRSNT\_N goes low when VSLR\_OVUVOUT greater than 16.3V



UNLESS OTHERWISE SPECIFIED:  
 RESISTORS ARE 0402 PACKAGE, POWER RATING < 0.5W & TOLERANCE > 1%  
 CAPACITORS ARE 0402 PACKAGE & TOLERANCE OF 10%



UART SEL	
LOW	A TO B1
HIGH	A TO B2



5

4

3

2

1

8

7

6

5

4

3

2

1

D

D

D

D

C

C

C

C

B

B

B

B

A

A

A

A

A

A

8

7

6

5

4

3

2

1


5

4

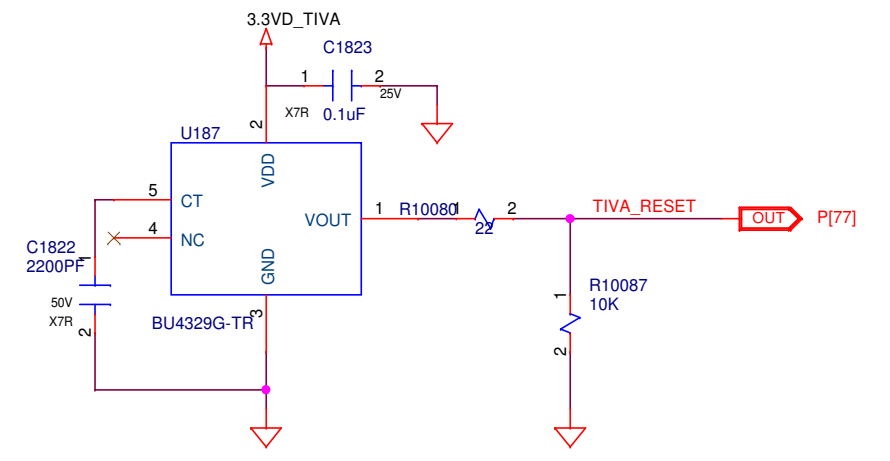
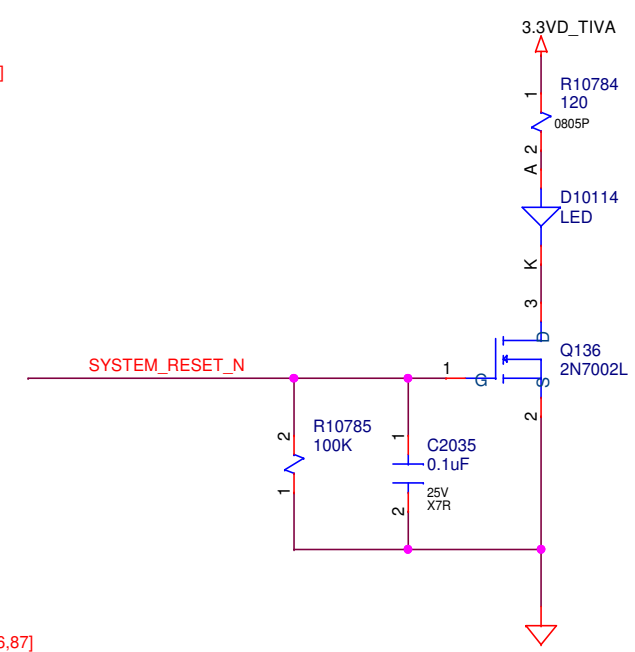
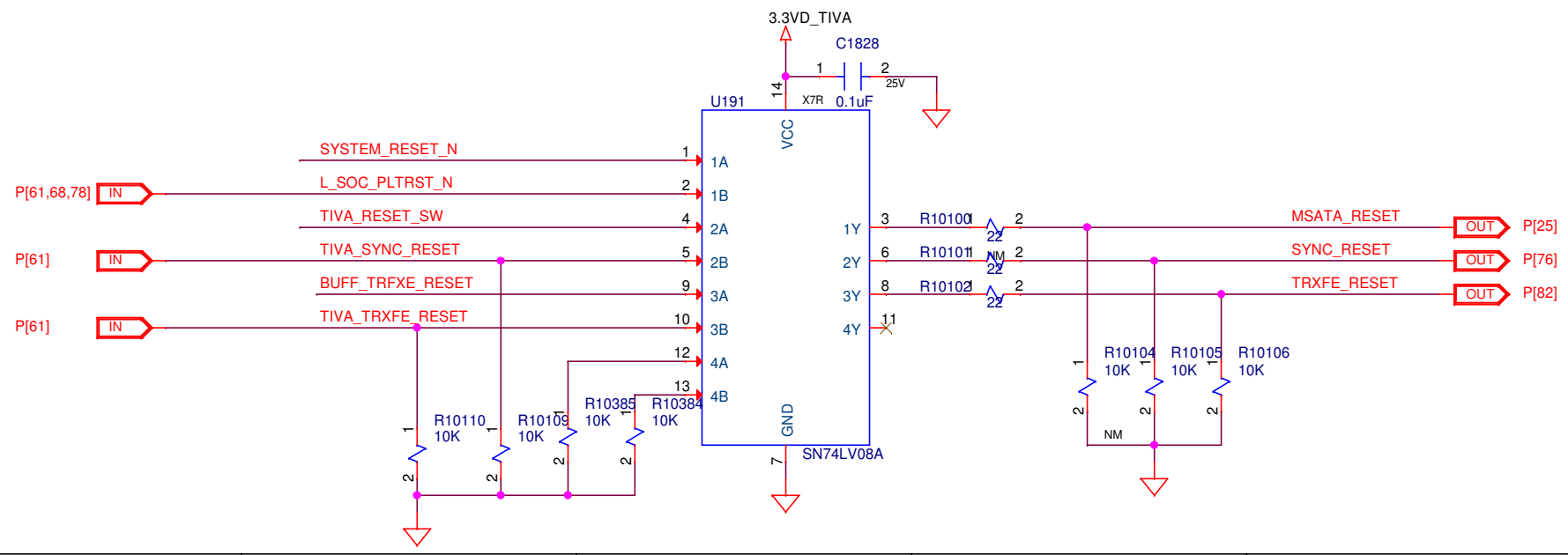
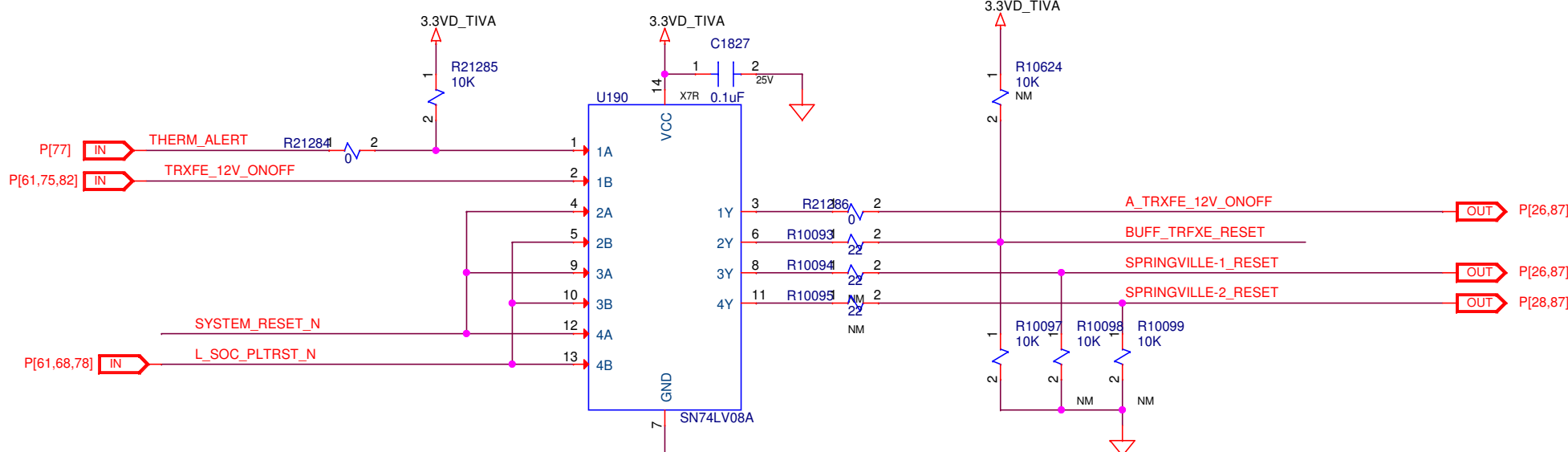
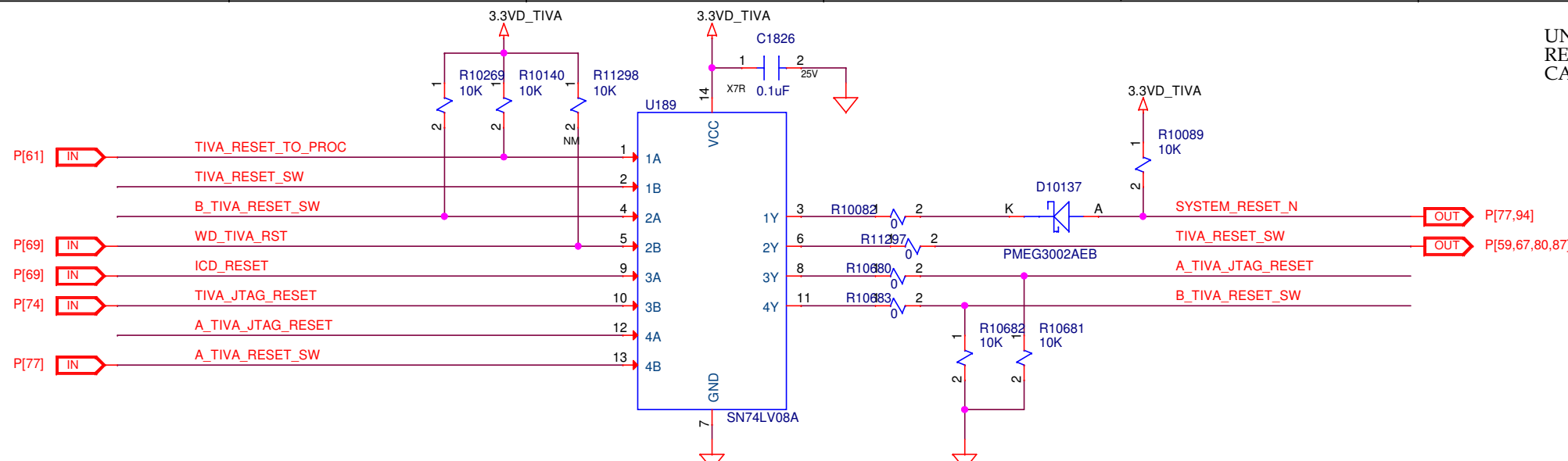
3

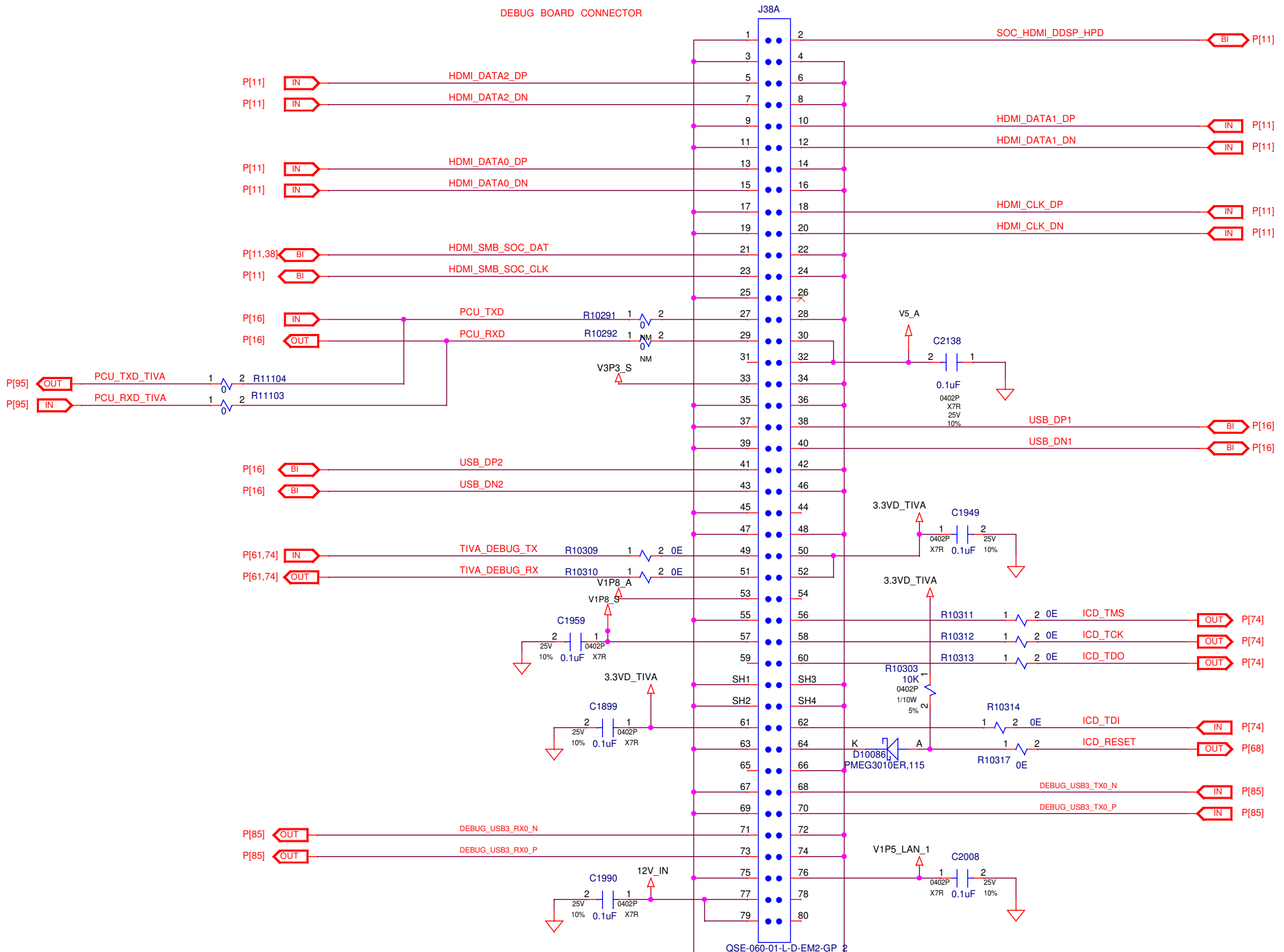
2


1

 <b>OpenCellular</b>	DOCUMENT NUMBER: 232-000036	
	TITLE: BLANK	LIFE 3

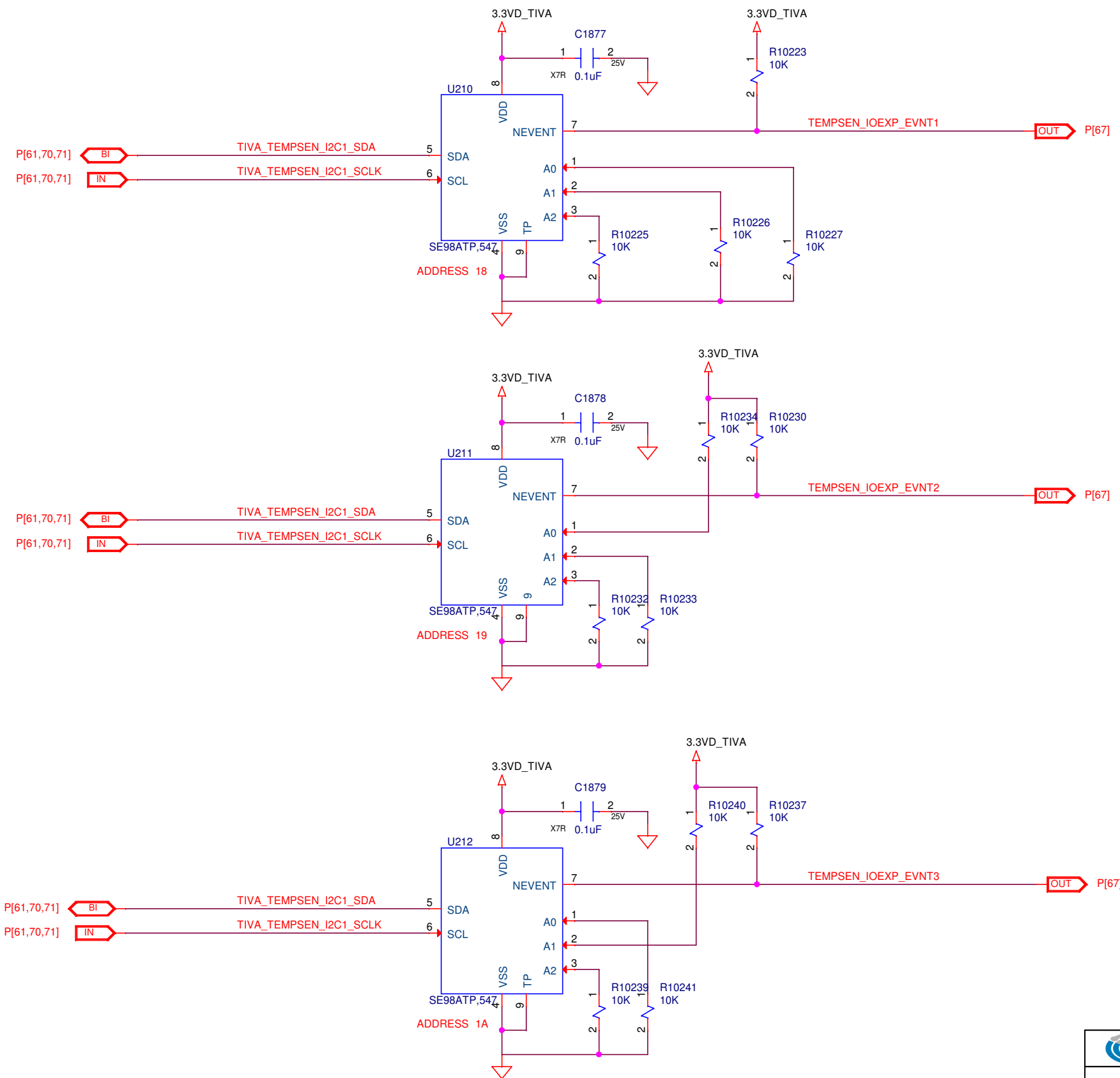
UNLESS OTHERWISE SPECIFIED:  
 RESISTORS ARE 0402 PACKAGE, POWER RATING < 0.5W & TOLERANCE > 1%  
 CAPACITORS ARE 0402 PACKAGE & TOLERANCE OF 10%






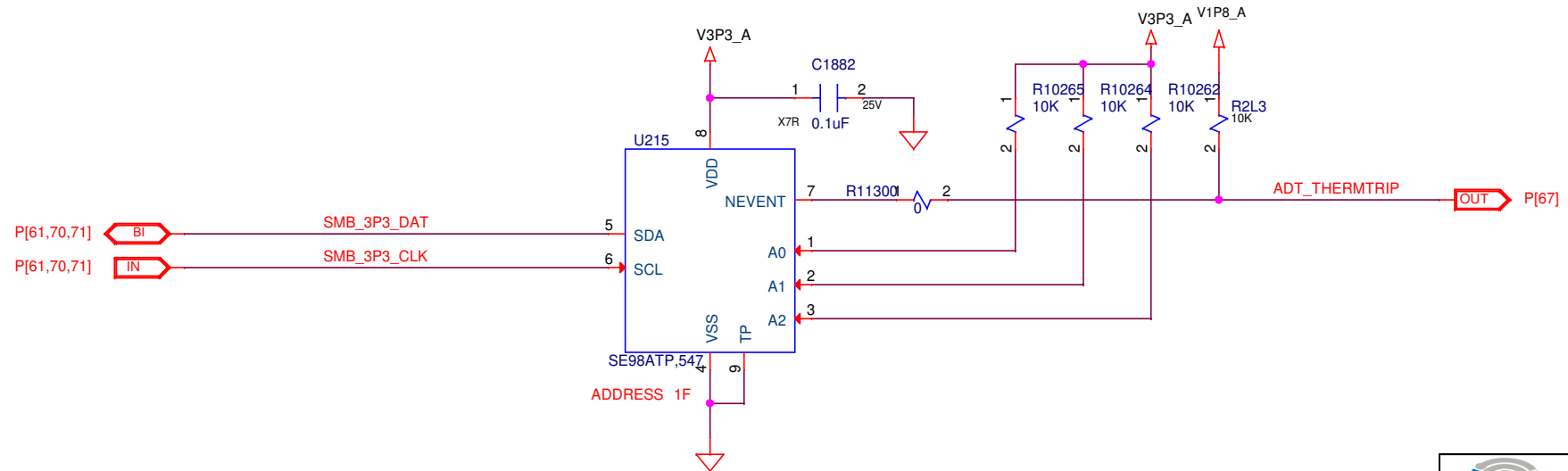
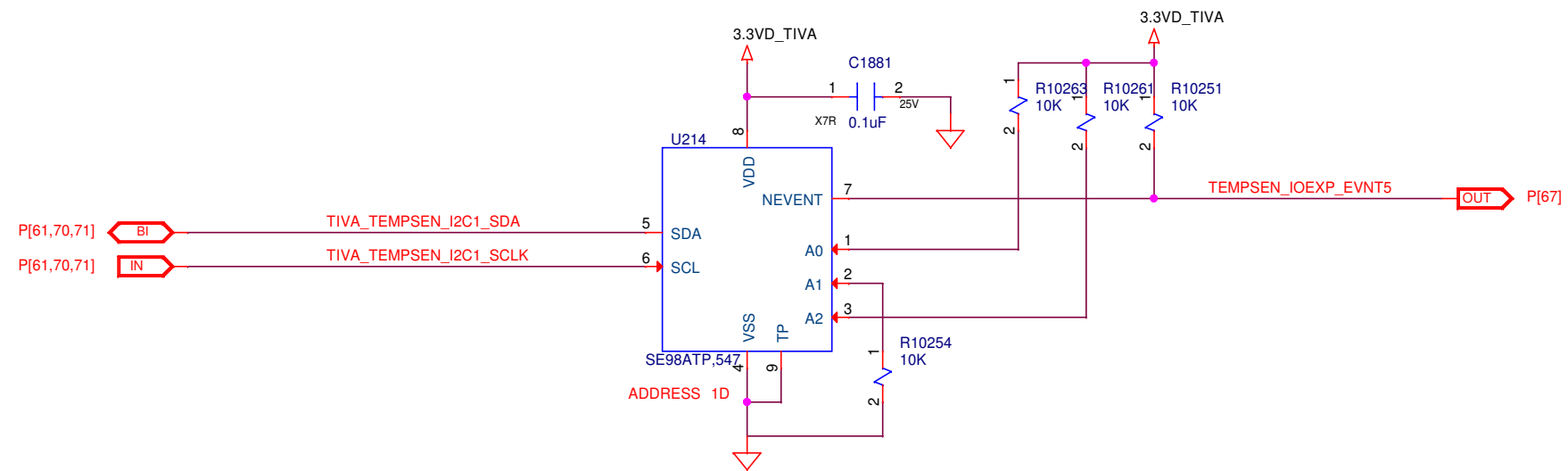
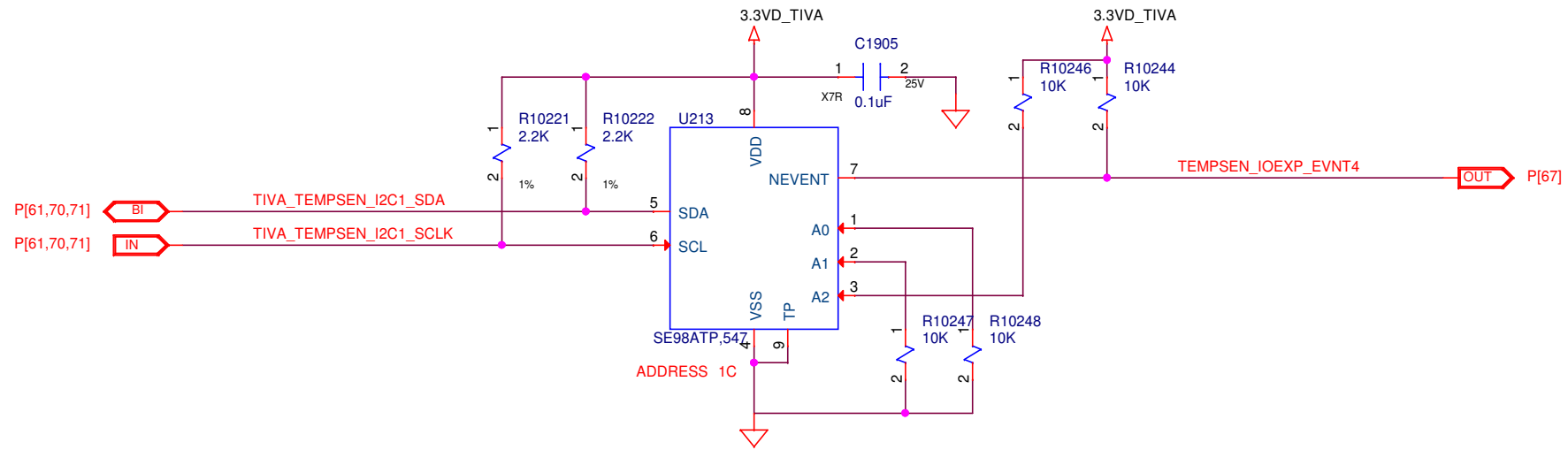
 <b>OpenCellular</b>	DOCUMENT NUMBER: 00	
	TITLE: DEBUG CONNECTOR	LIFE 1.01

UNLESS OTHERWISE SPECIFIED:  
 RESISTORS ARE 0402 PACKAGE, POWER RATING < 0.5W & TOLERANCE > 1%  
 CAPACITORS ARE 0402 PACKAGE & TOLERANCE OF 10%




 <b>OpenCellular</b>	DOCUMENT NUMBER: 232-000036	
	TITLE: TEMP SENSORS	LIFE 3

UNLESS OTHERWISE SPECIFIED:  
 RESISTORS ARE 0402 PACKAGE, POWER RATING < 0.5W & TOLERANCE > 1%  
 CAPACITORS ARE 0402 PACKAGE & TOLERANCE OF 10%

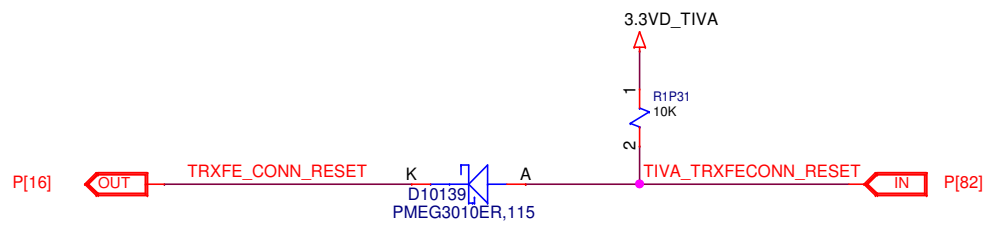
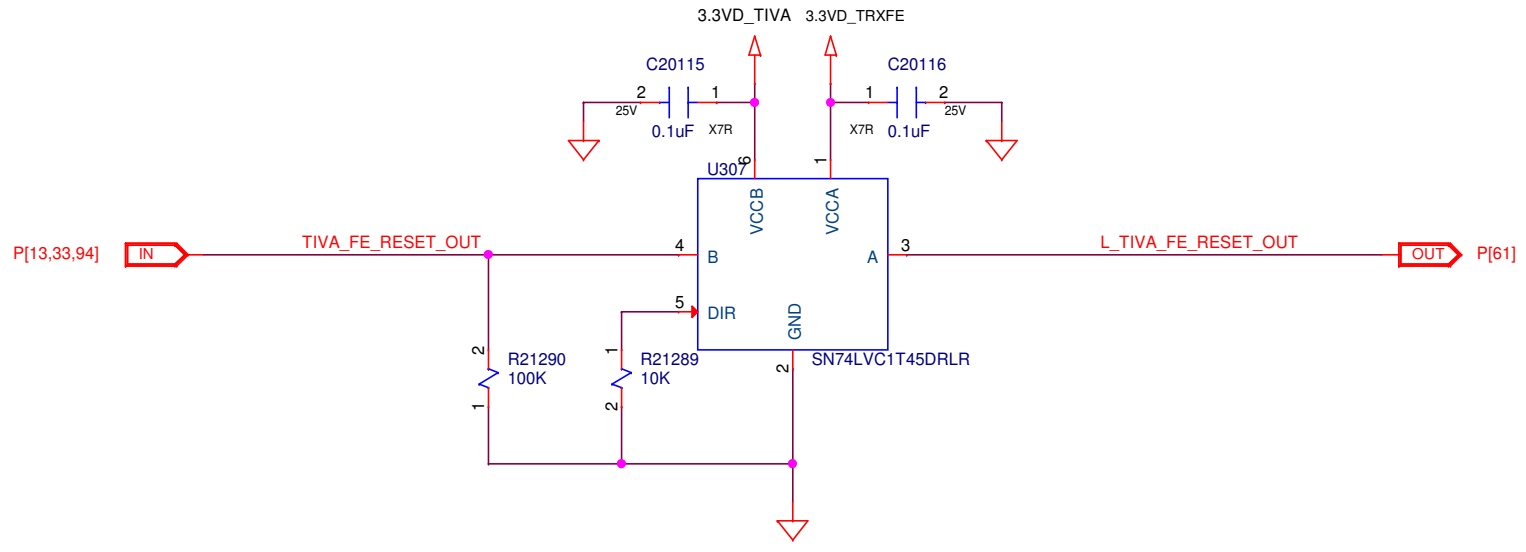
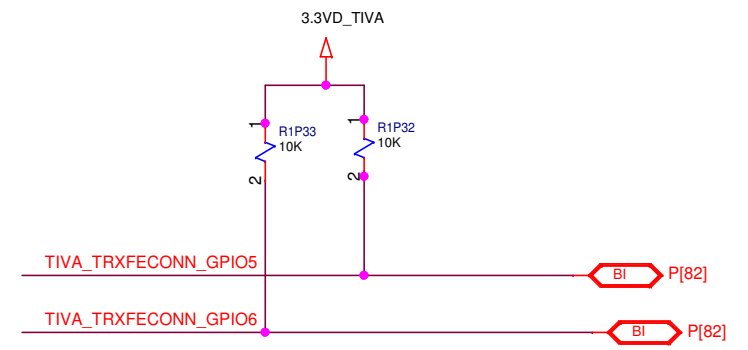
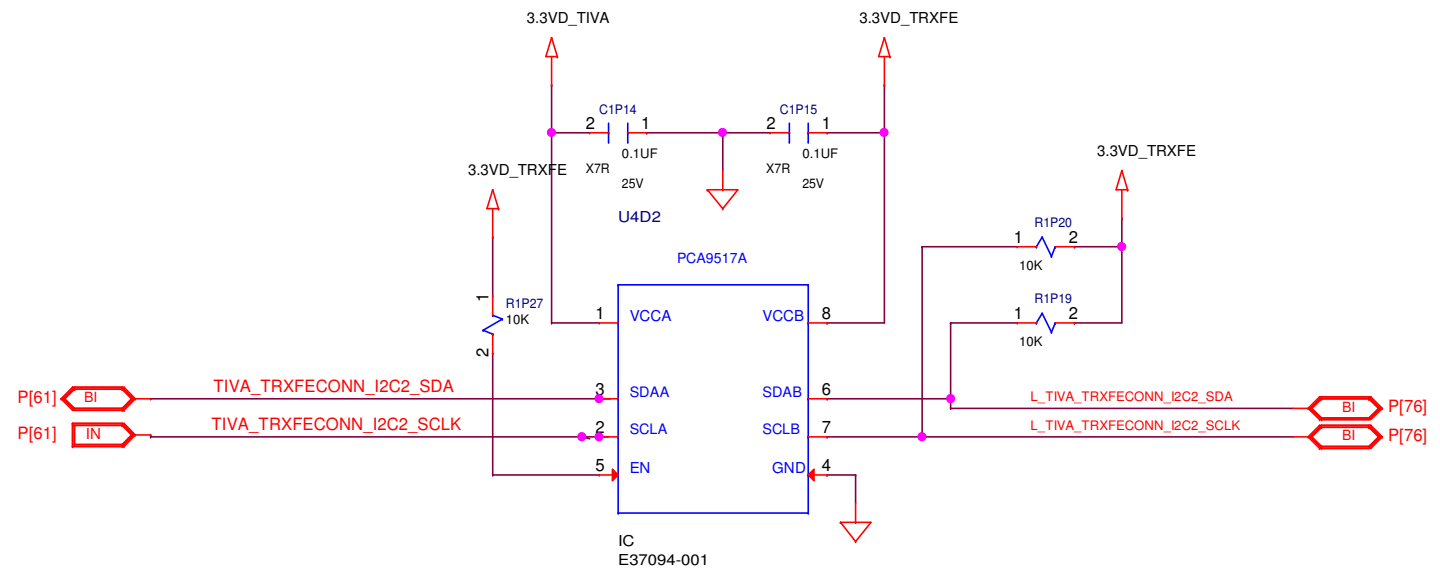


UNLESS OTHERWISE SPECIFIED:  
RESISTORS ARE 0402 PACKAGE, POWER RATING < 0.5W & TOLERANCE > 1%  
CAPACITORS ARE 0402 PACKAGE & TOLERANCE OF 10%

 <b>OpenCellular</b>	DOCUMENT NUMBER: 232-000036	
	TITLE: SOC ISOLATION	SHEET 72 OF 96

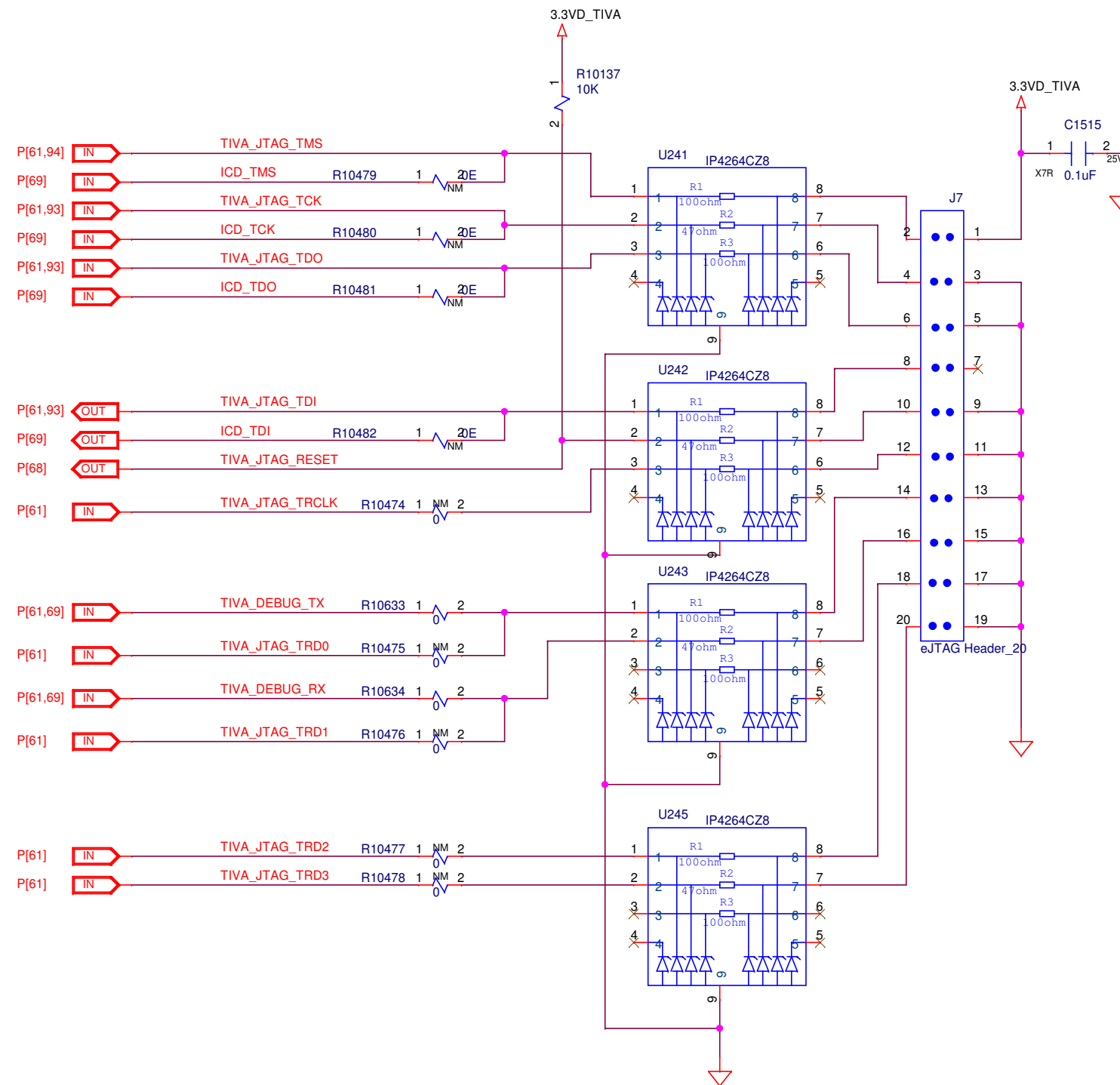



UNLESS OTHERWISE SPECIFIED:  
 RESISTORS ARE 0402 PACKAGE, POWER RATING < 0.5W & TOLERANCE > 1%  
 CAPACITORS ARE 0402 PACKAGE & TOLERANCE OF 10%



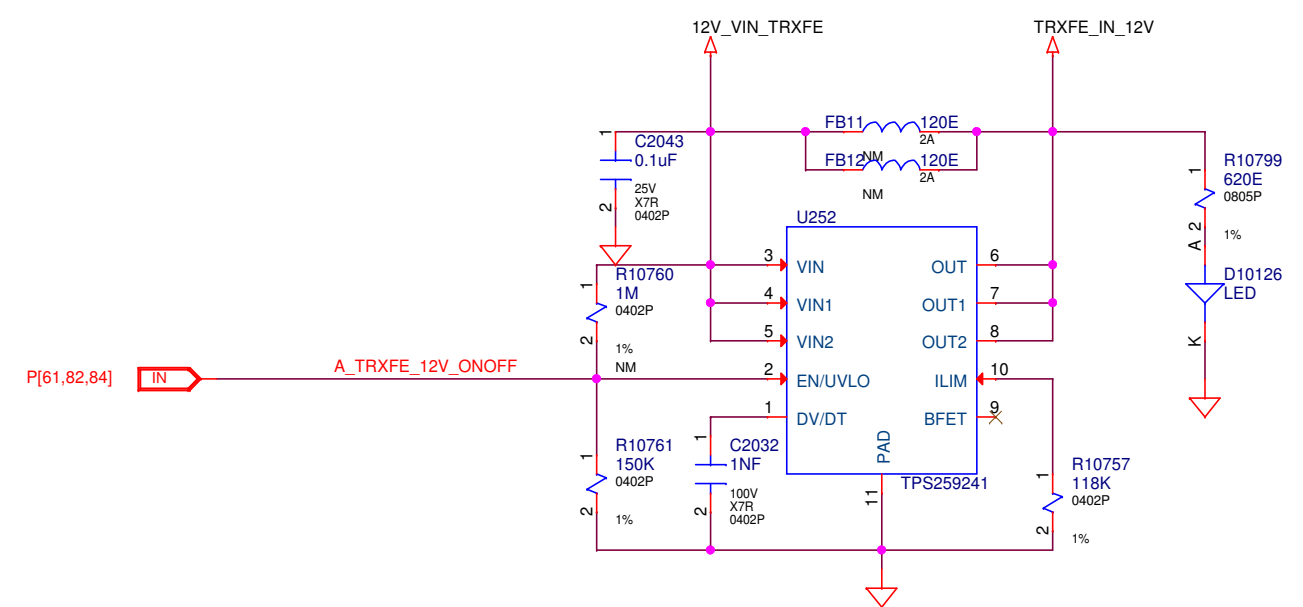
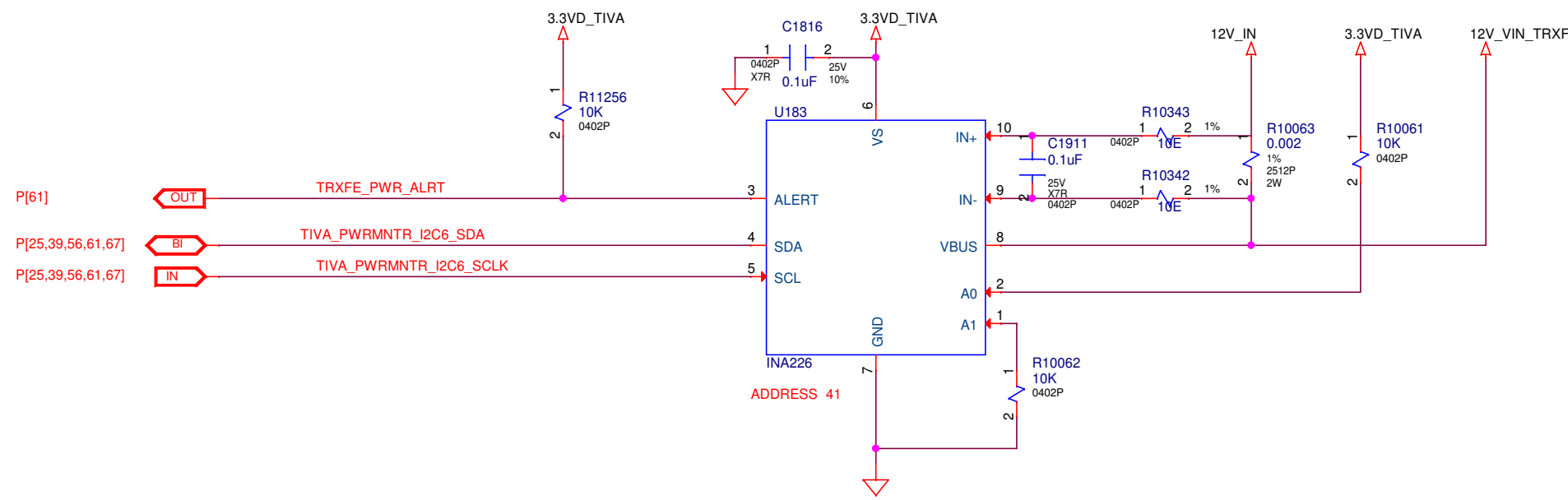
UNLESS OTHERWISE SPECIFIED:  
 RESISTORS ARE 0402 PACKAGE, POWER RATING < 0.5W & TOLERANCE > 1%  
 CAPACITORS ARE 0402 PACKAGE & TOLERANCE OF 10%

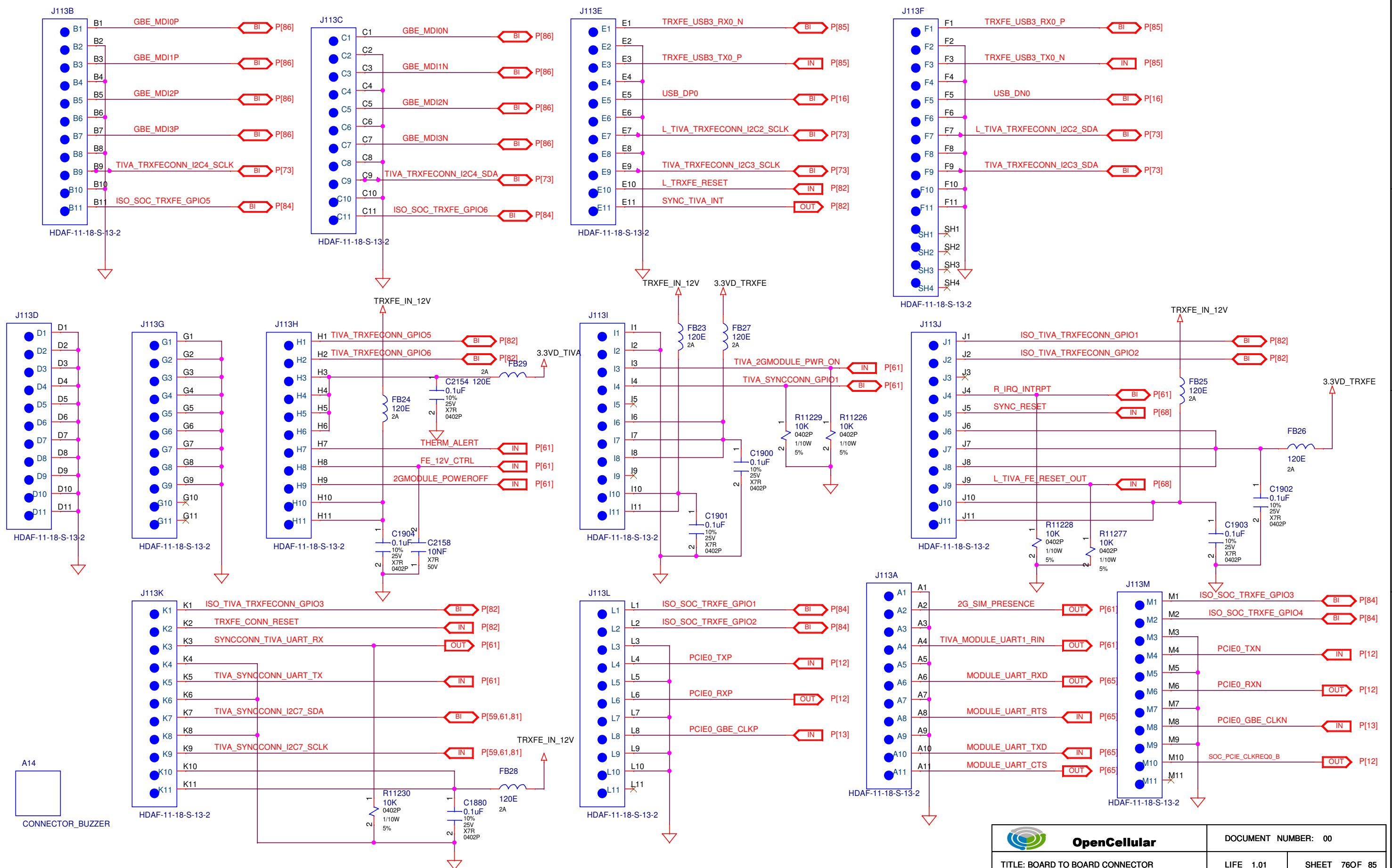
TIVA JTAG CONNECTOR



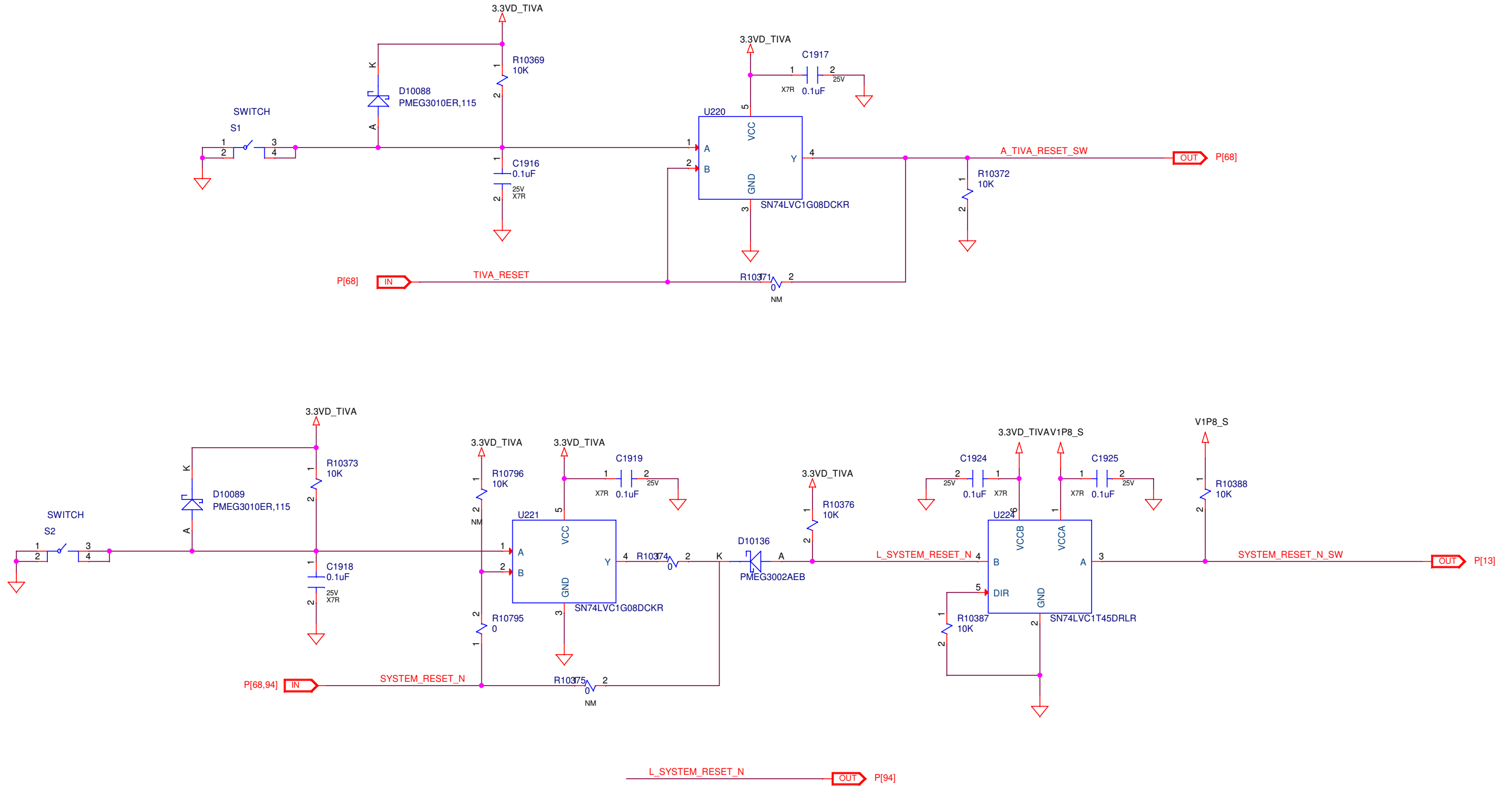
 <b>OpenCellular</b>	DOCUMENT NUMBER: 232-000036	
	TITLE: TIVA JTAG CONNECTOR	LIFE 3

UNLESS OTHERWISE SPECIFIED:  
 RESISTORS ARE 0402 PACKAGE, POWER RATING < 0.5W & TOLERANCE > 1%  
 CAPACITORS ARE 0402 PACKAGE & TOLERANCE OF 10%

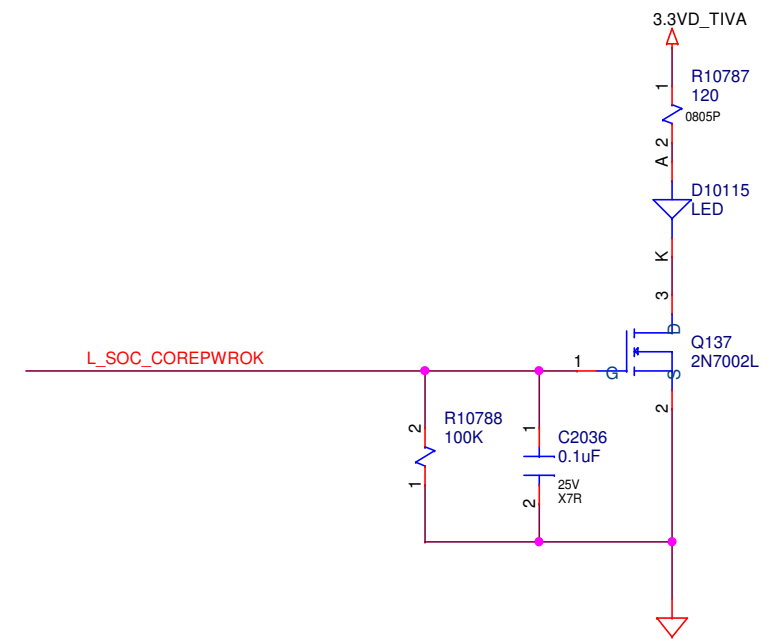
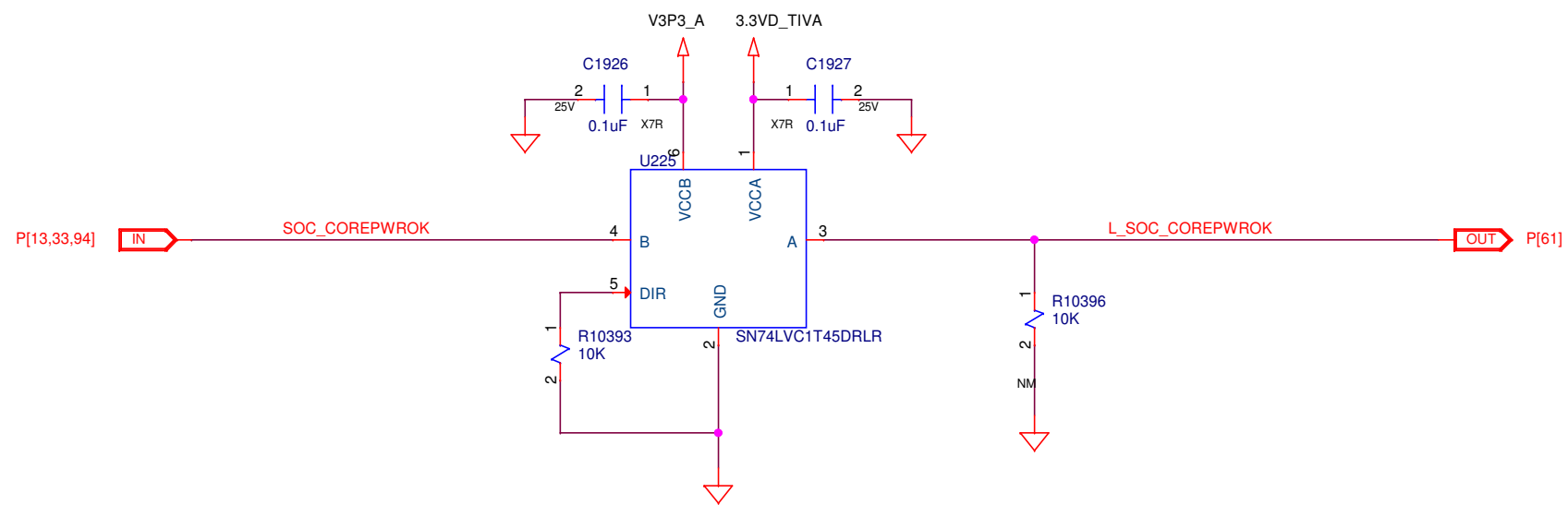
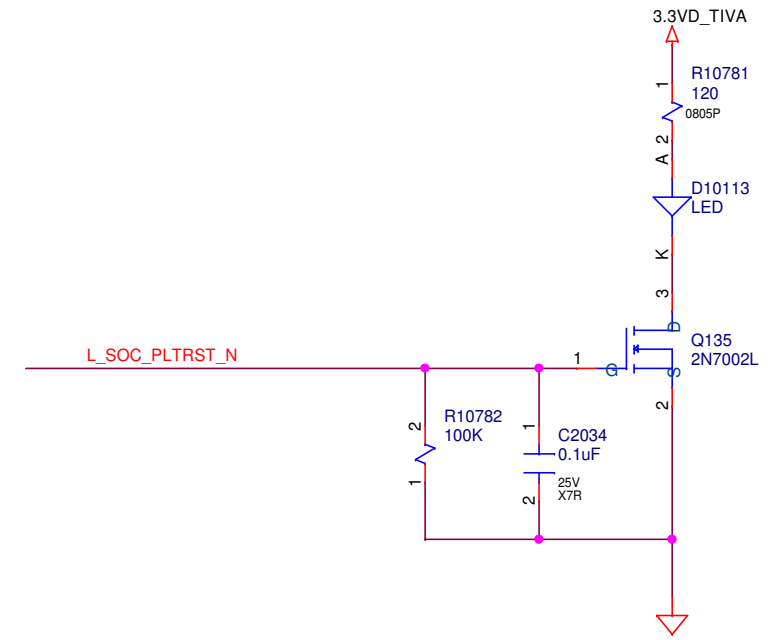
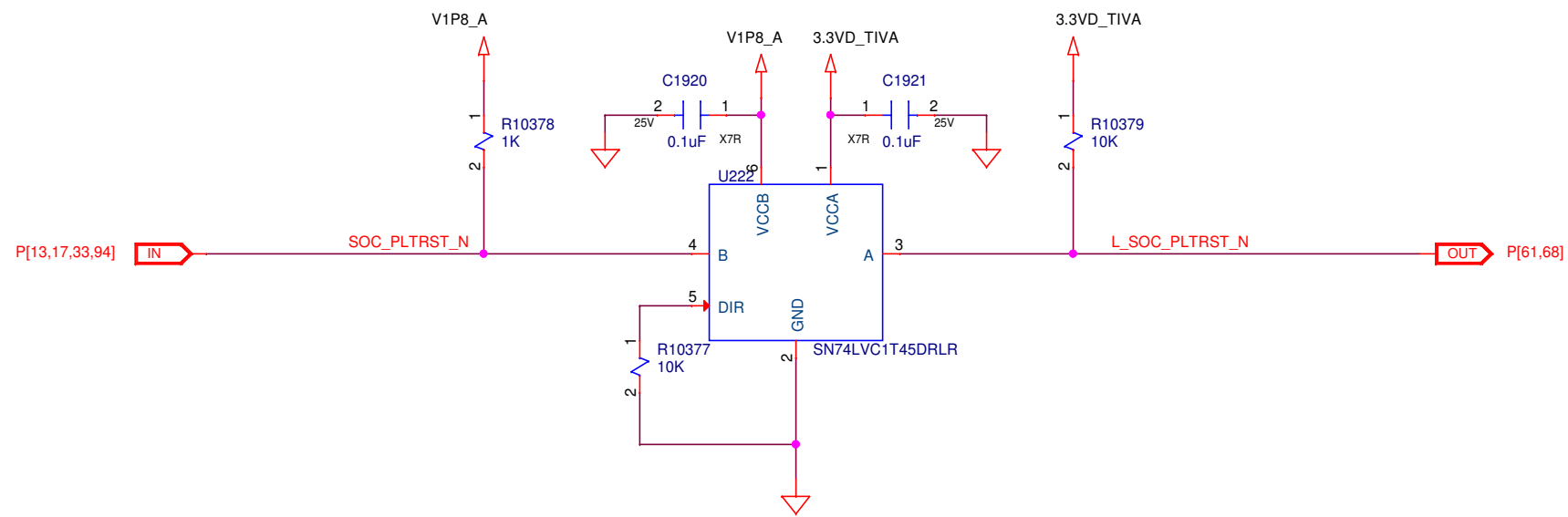




UNLESS OTHERWISE SPECIFIED:  
 RESISTORS ARE 0402 PACKAGE, POWER RATING < 0.5W & TOLERANCE > 1%  
 CAPACITORS ARE 0402 PACKAGE & TOLERANCE OF 10%



UNLESS OTHERWISE SPECIFIED:  
 RESISTORS ARE 0402 PACKAGE, POWER RATING < 0.5W & TOLERANCE > 1%  
 CAPACITORS ARE 0402 PACKAGE & TOLERANCE OF 10%



8 7 6 5 4 3 2 1

D

D

C

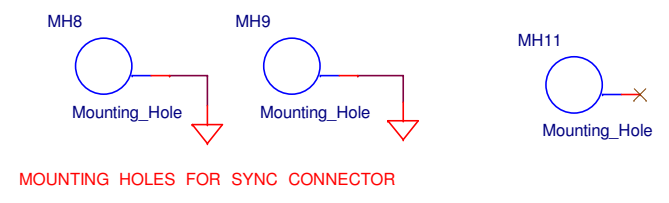
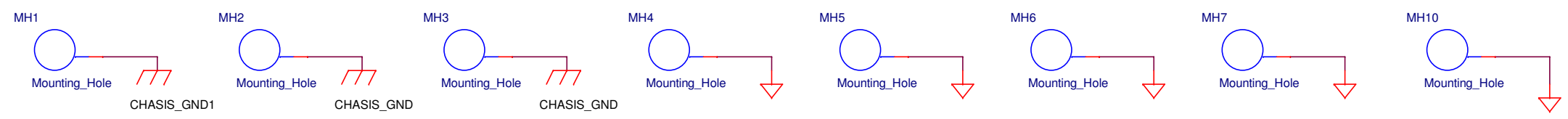
C


B

B

A

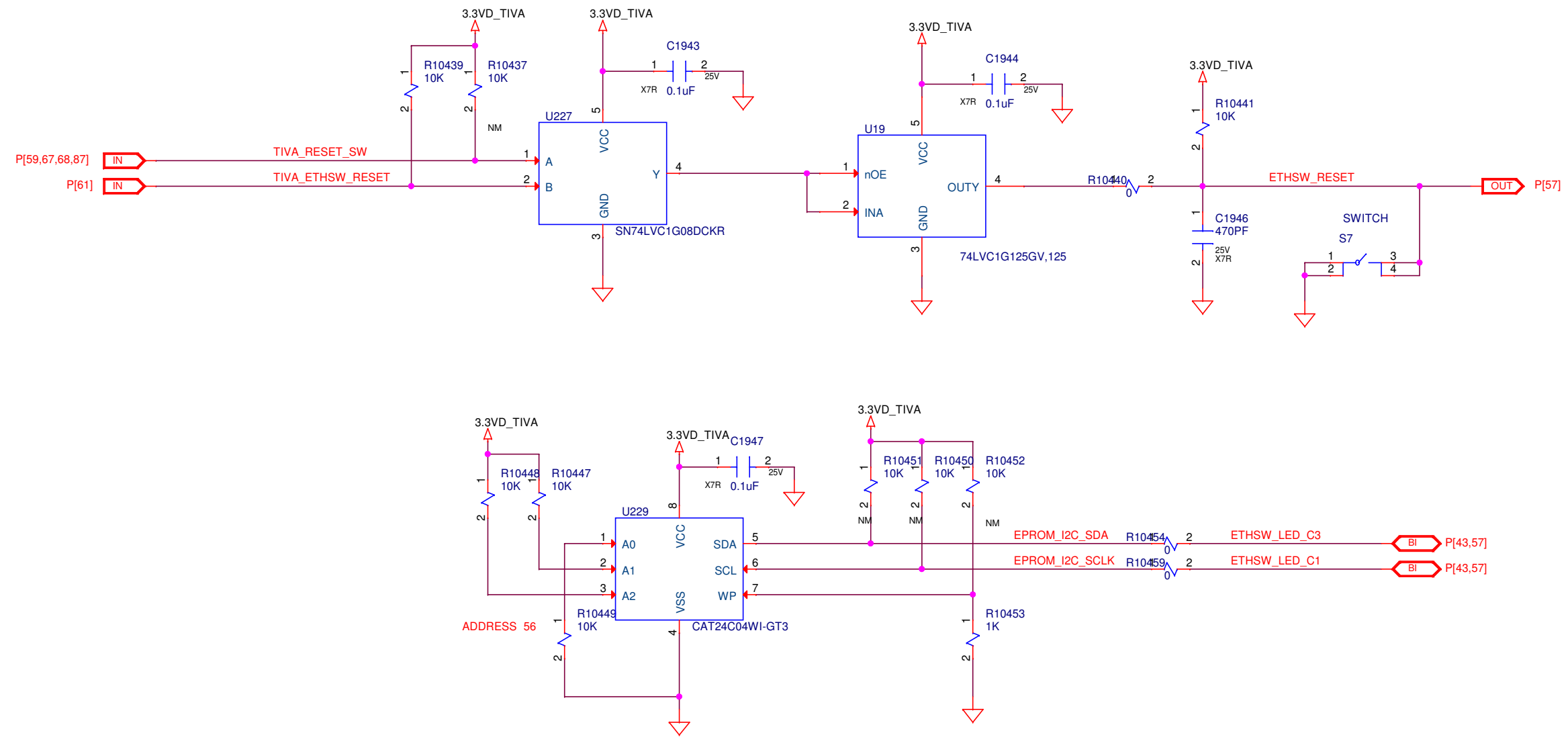
A



 <b>OpenCellular</b>	DOCUMENT NUMBER: 232-000036	
	TITLE: MTG HOLES	SHEET 79 OF 96

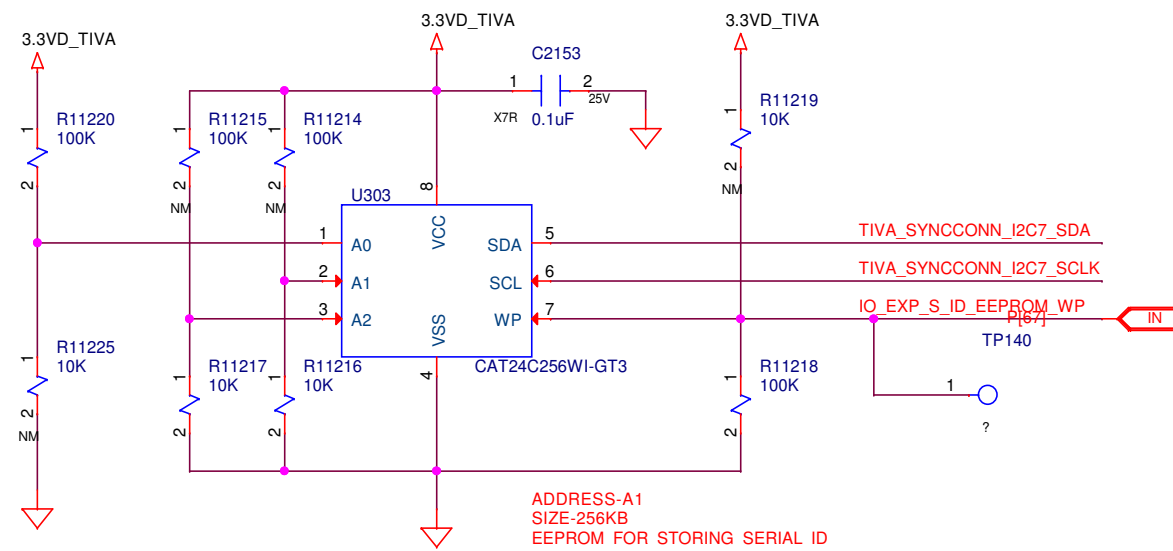
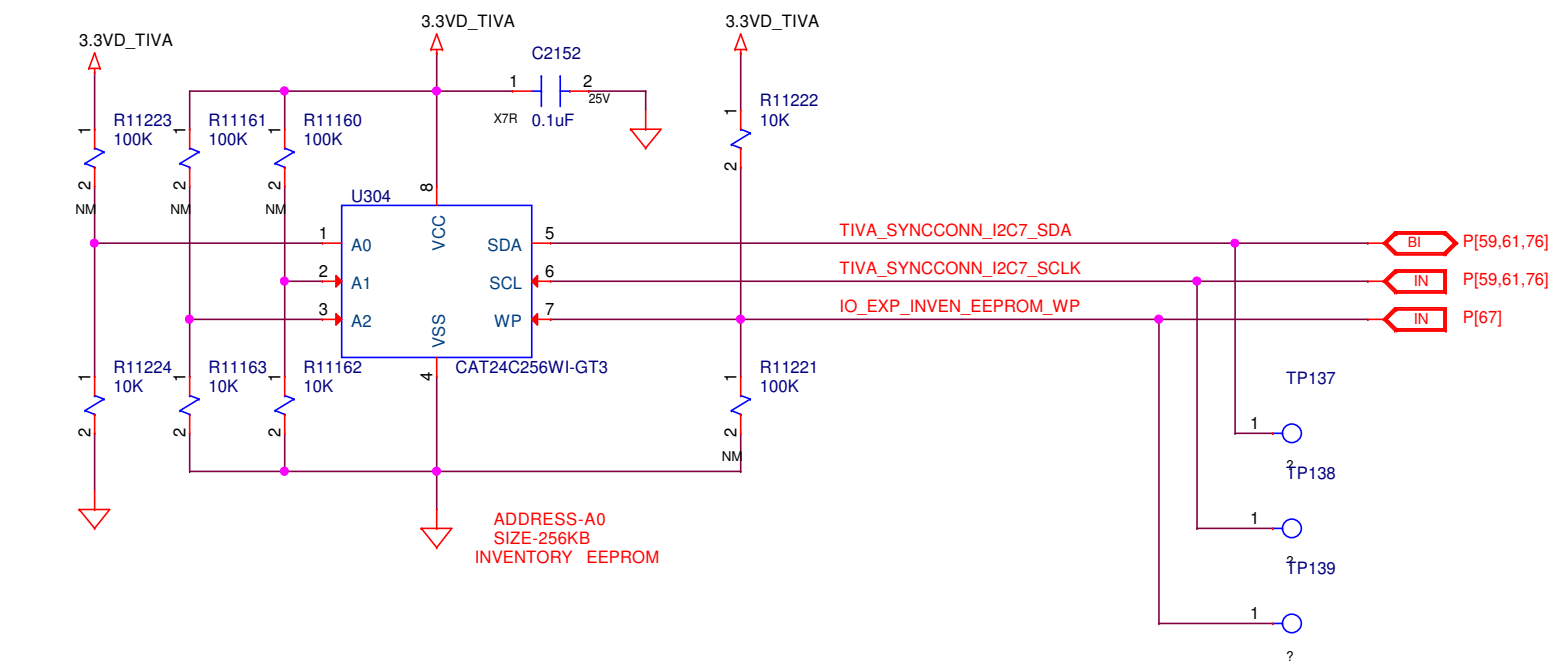
8 7 6 5 4 3 2 1

UNLESS OTHERWISE SPECIFIED:  
 RESISTORS ARE 0402 PACKAGE, POWER RATING < 0.5W & TOLERANCE > 1%  
 CAPACITORS ARE 0402 PACKAGE & TOLERANCE OF 10%

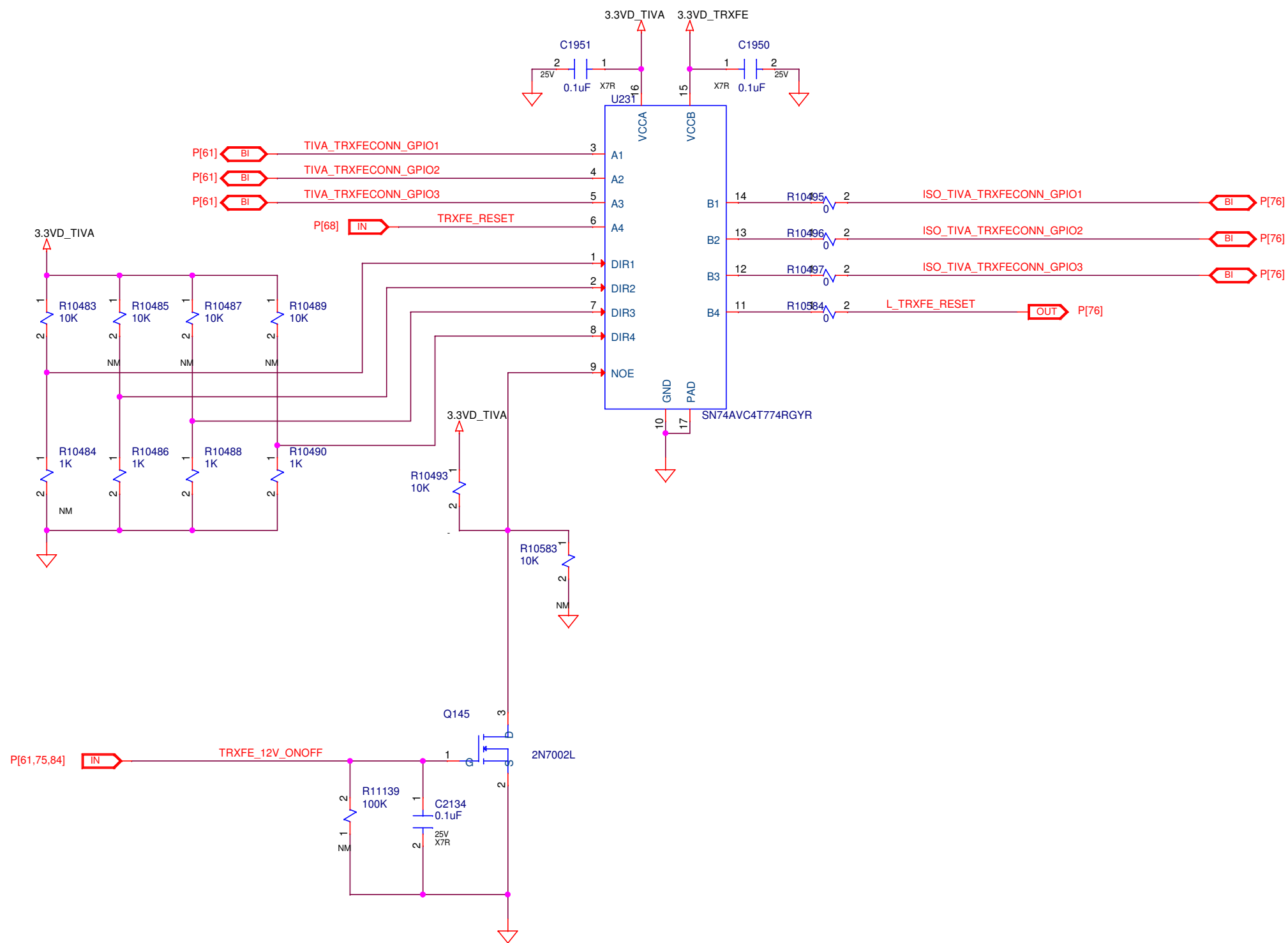





UNLESS OTHERWISE SPECIFIED:  
 RESISTORS ARE 0402 PACKAGE, POWER RATING < 0.5W & TOLERANCE > 1%  
 CAPACITORS ARE 0402 PACKAGE & TOLERANCE OF 10%

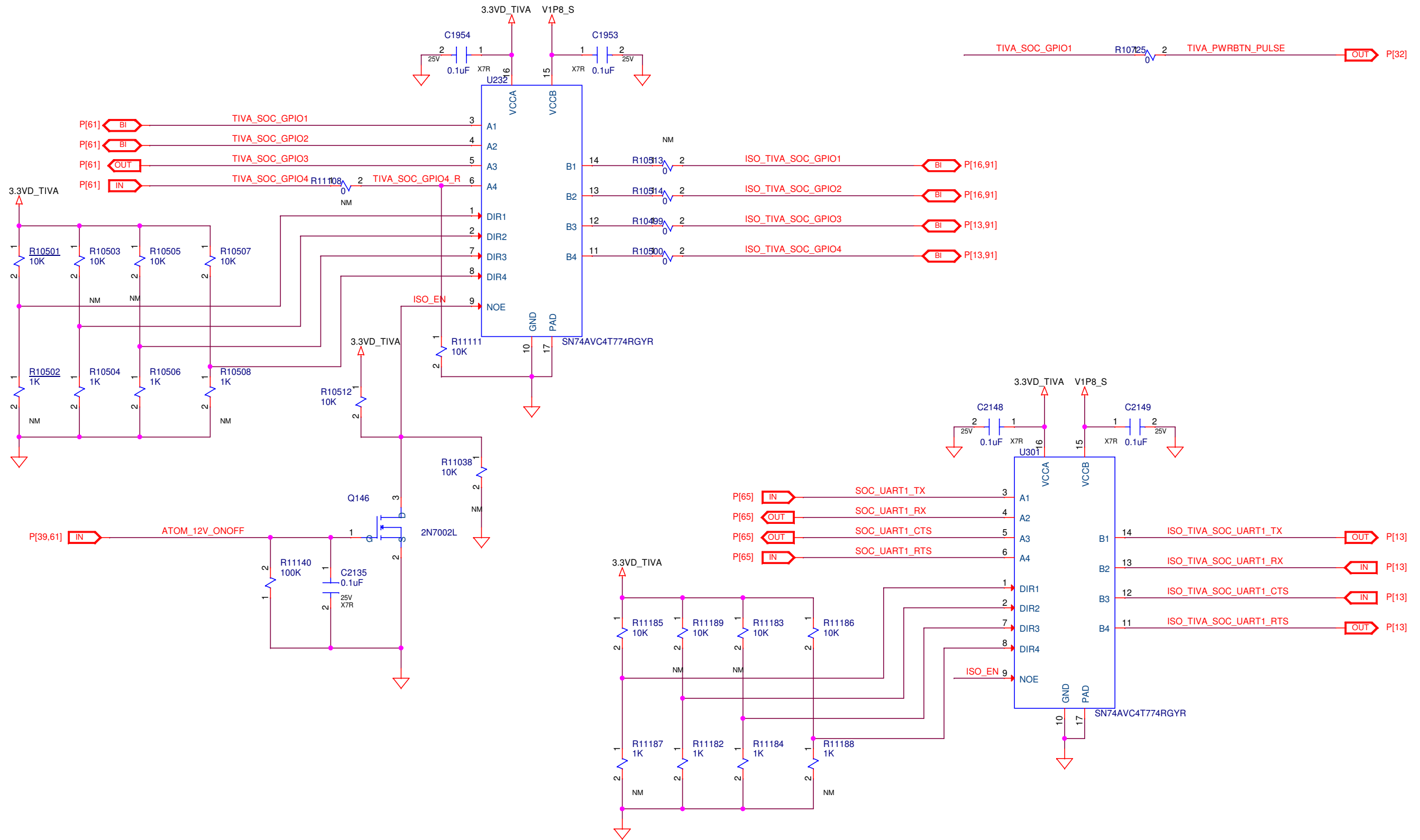


UNLESS OTHERWISE SPECIFIED:  
 RESISTORS ARE 0402 PACKAGE, POWER RATING < 0.5W & TOLERANCE > 1%  
 CAPACITORS ARE 0402 PACKAGE & TOLERANCE OF 10%

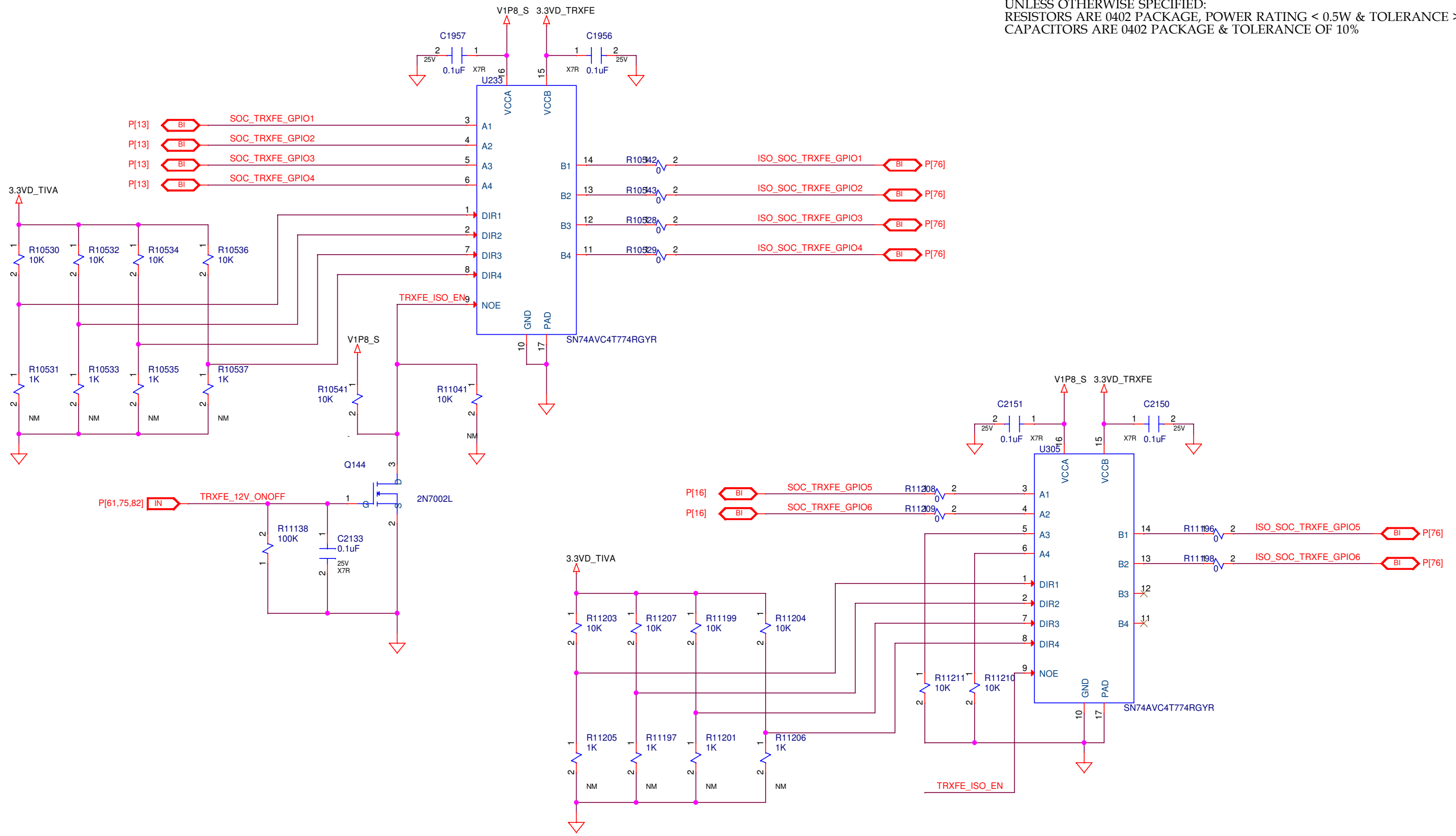


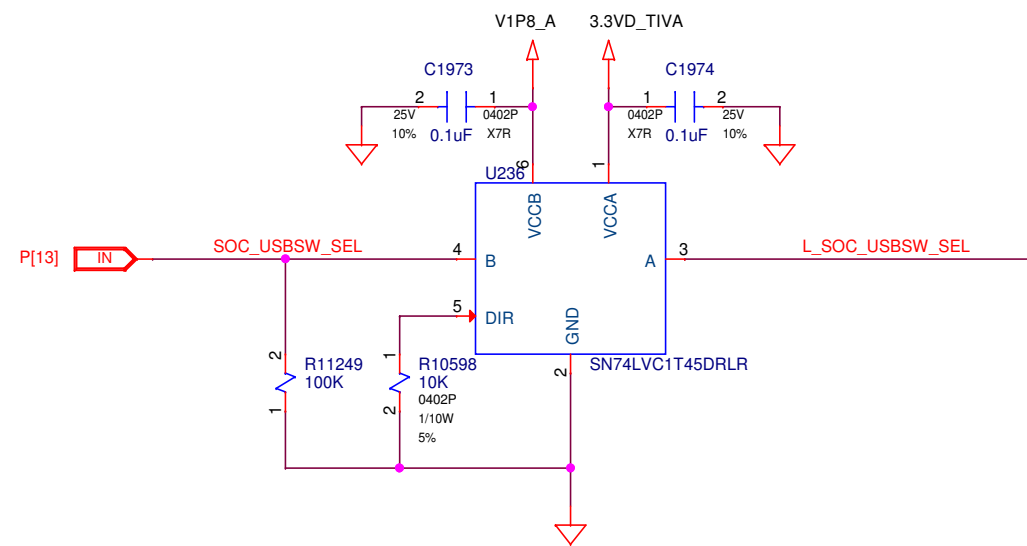
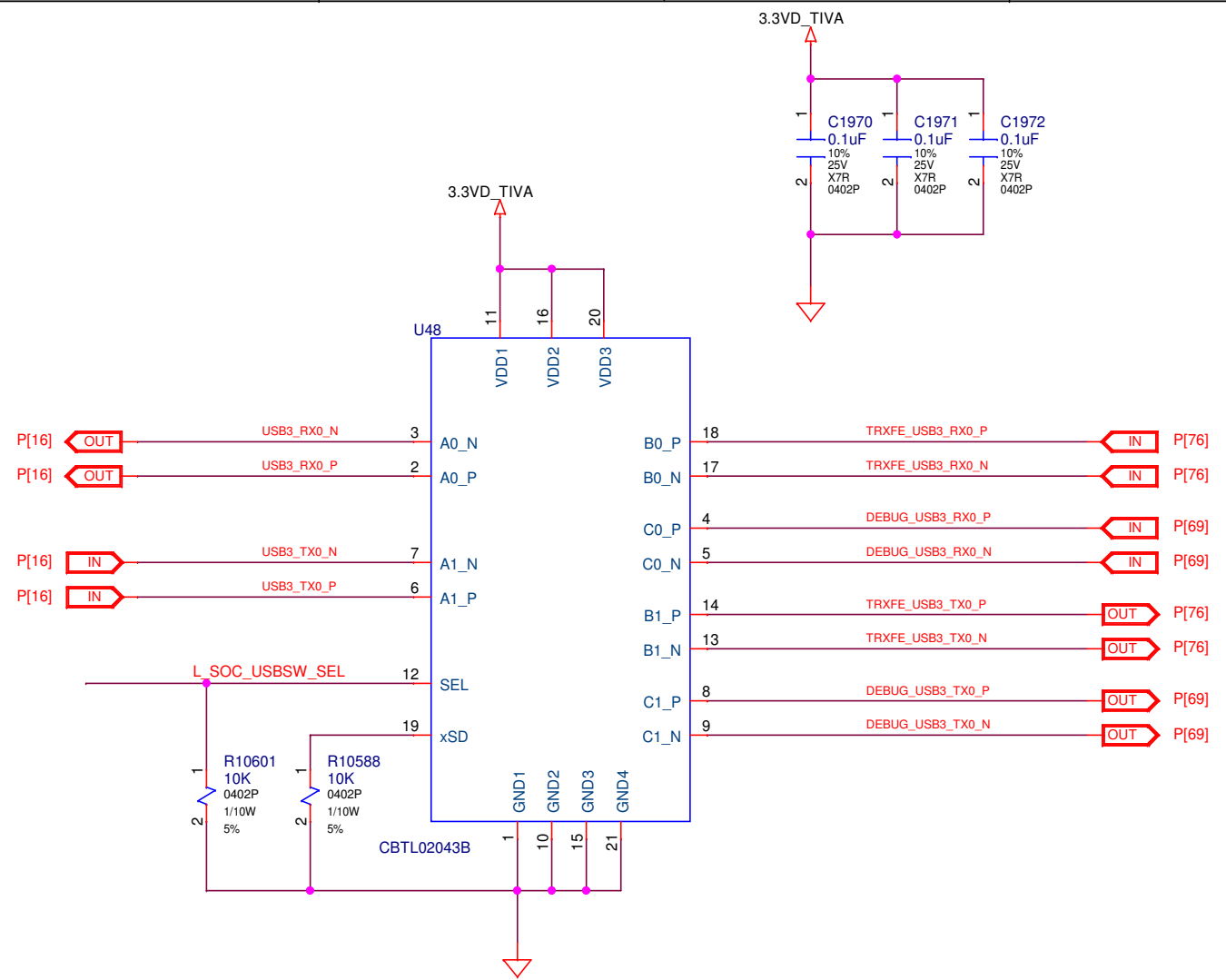
 <b>OpenCellular</b>	DOCUMENT NUMBER: 232-000036	
	LIFE 3	SHEET 82 OF 96

UNLESS OTHERWISE SPECIFIED:  
 RESISTORS ARE 0402 PACKAGE, POWER RATING < 0.5W & TOLERANCE > 1%  
 CAPACITORS ARE 0402 PACKAGE & TOLERANCE OF 10%

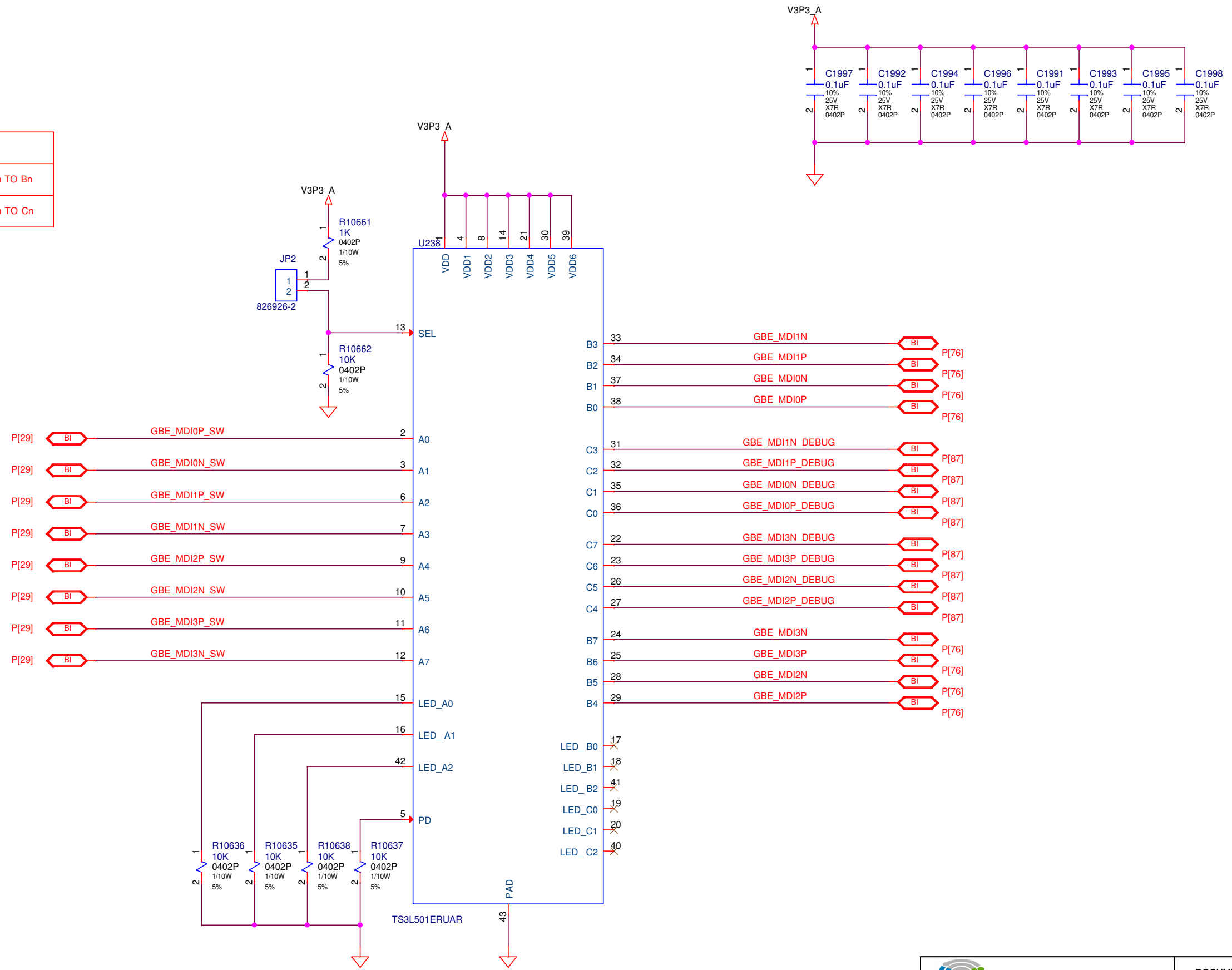


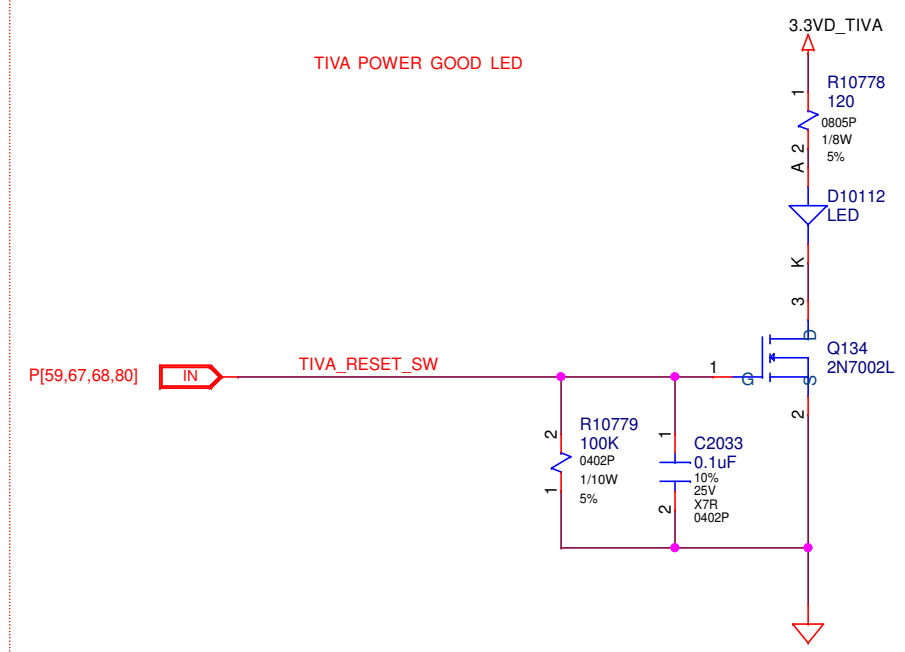
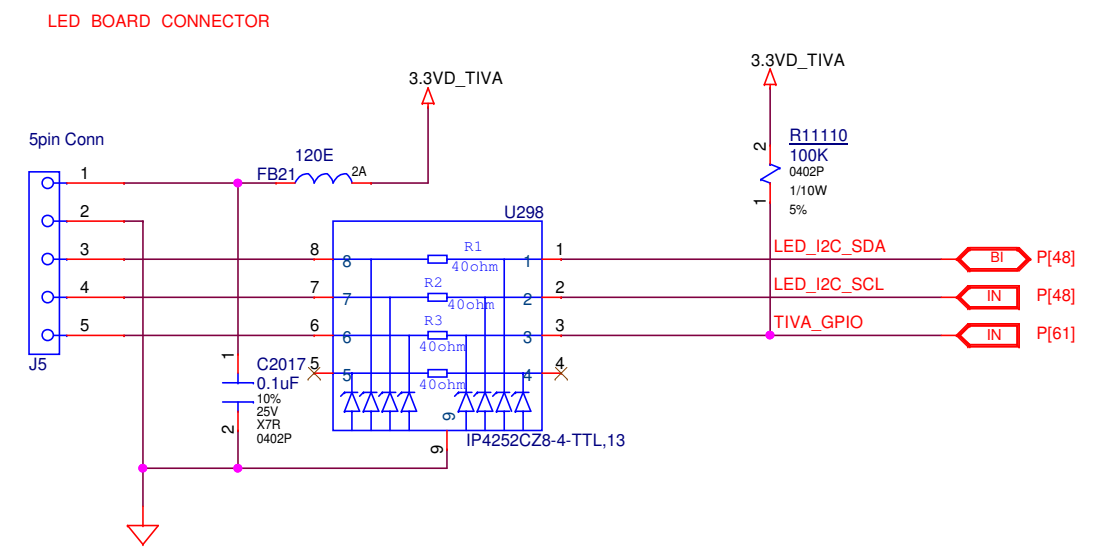
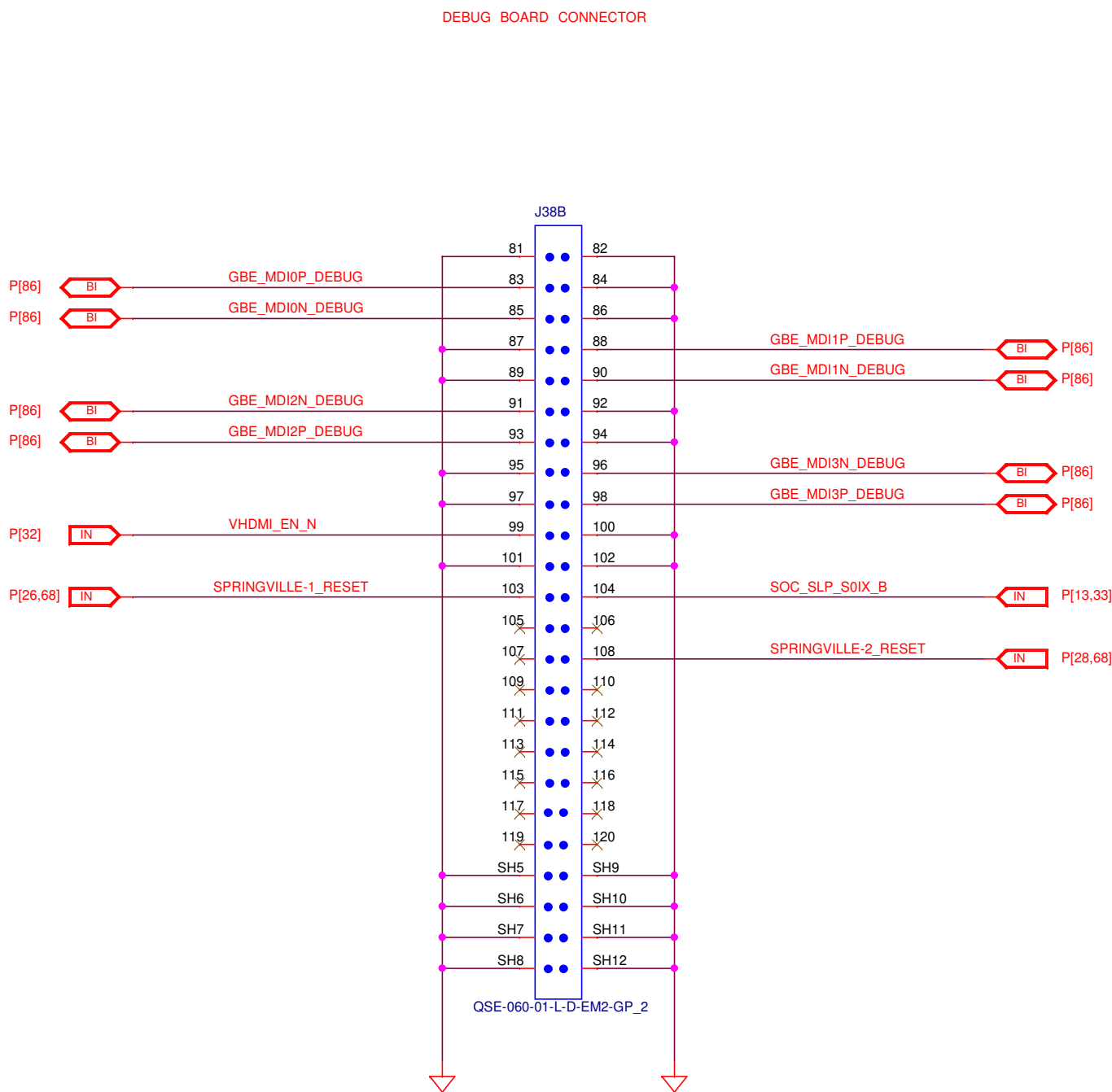
UNLESS OTHERWISE SPECIFIED:  
 RESISTORS ARE 0402 PACKAGE, POWER RATING < 0.5W & TOLERANCE > 1%  
 CAPACITORS ARE 0402 PACKAGE & TOLERANCE OF 10%



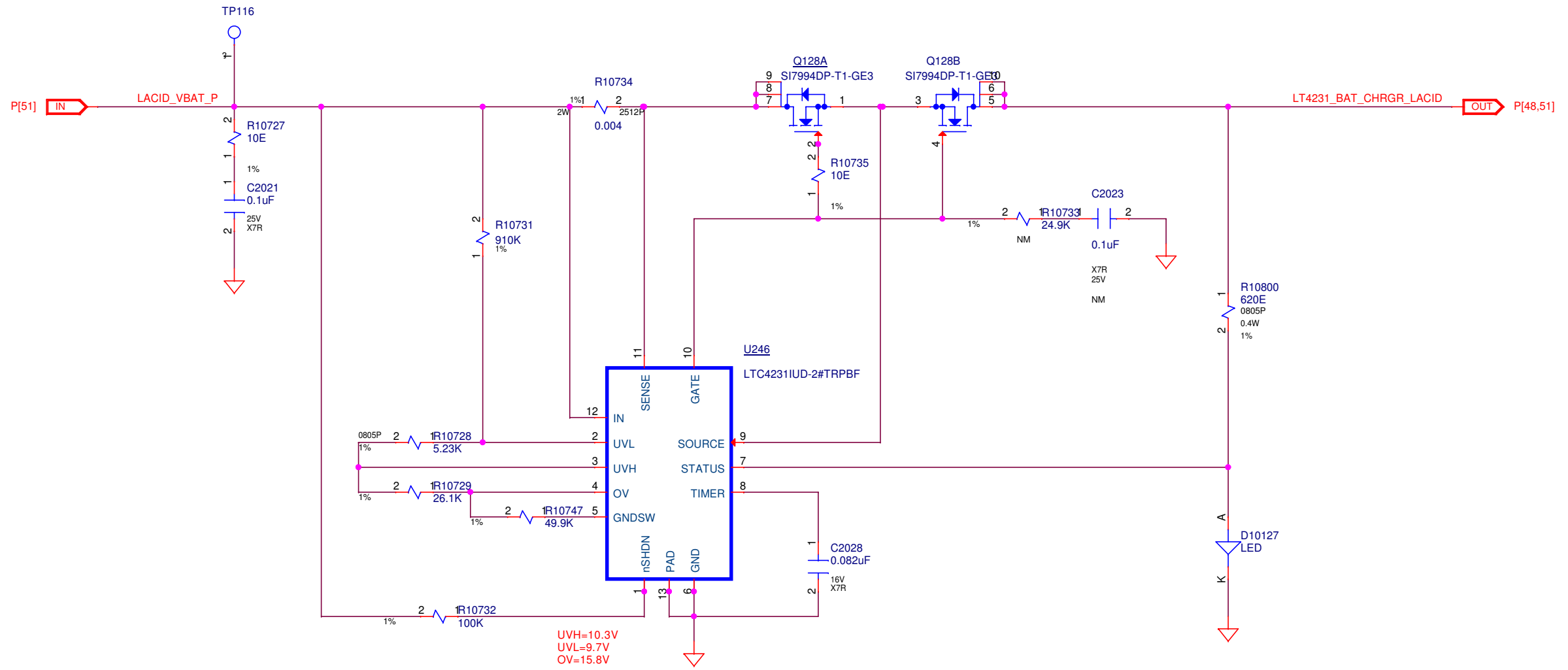



SEL	
LOW	An TO Bn
HIGH	An TO Cn





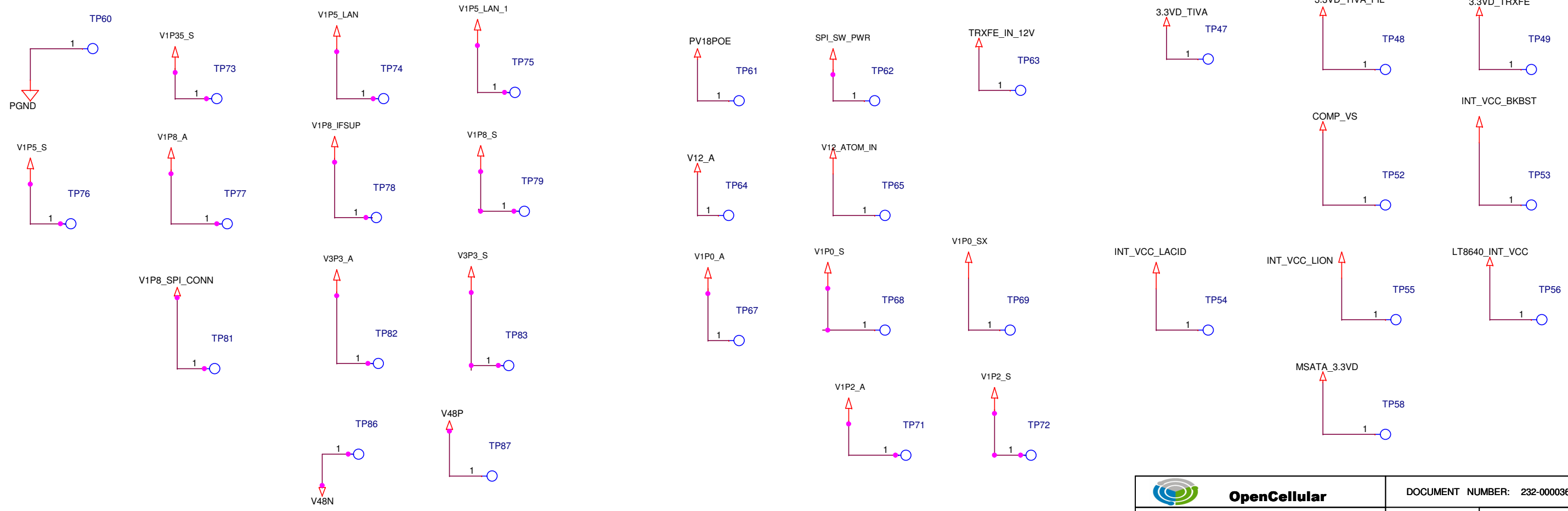
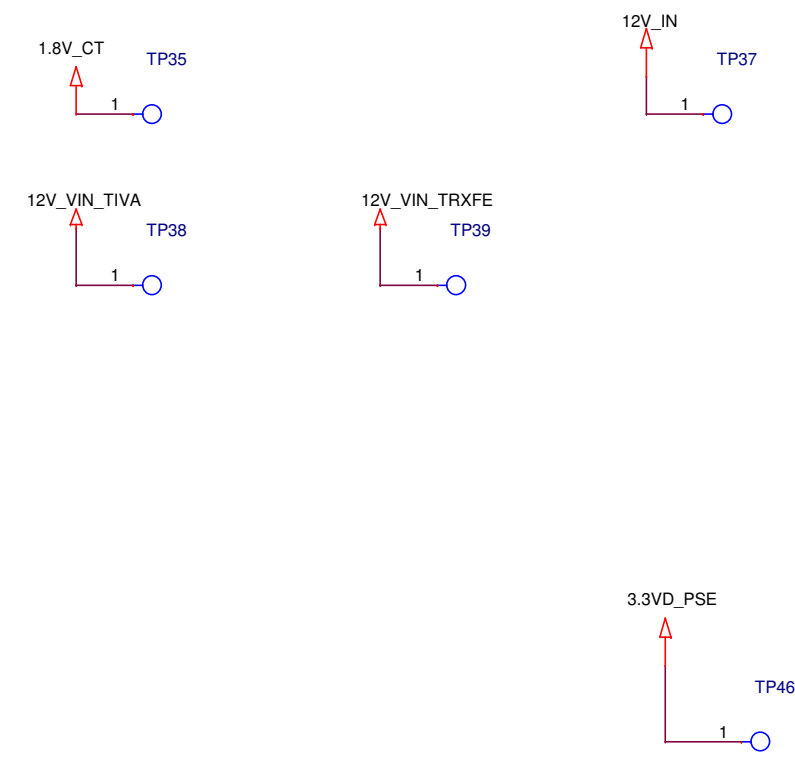
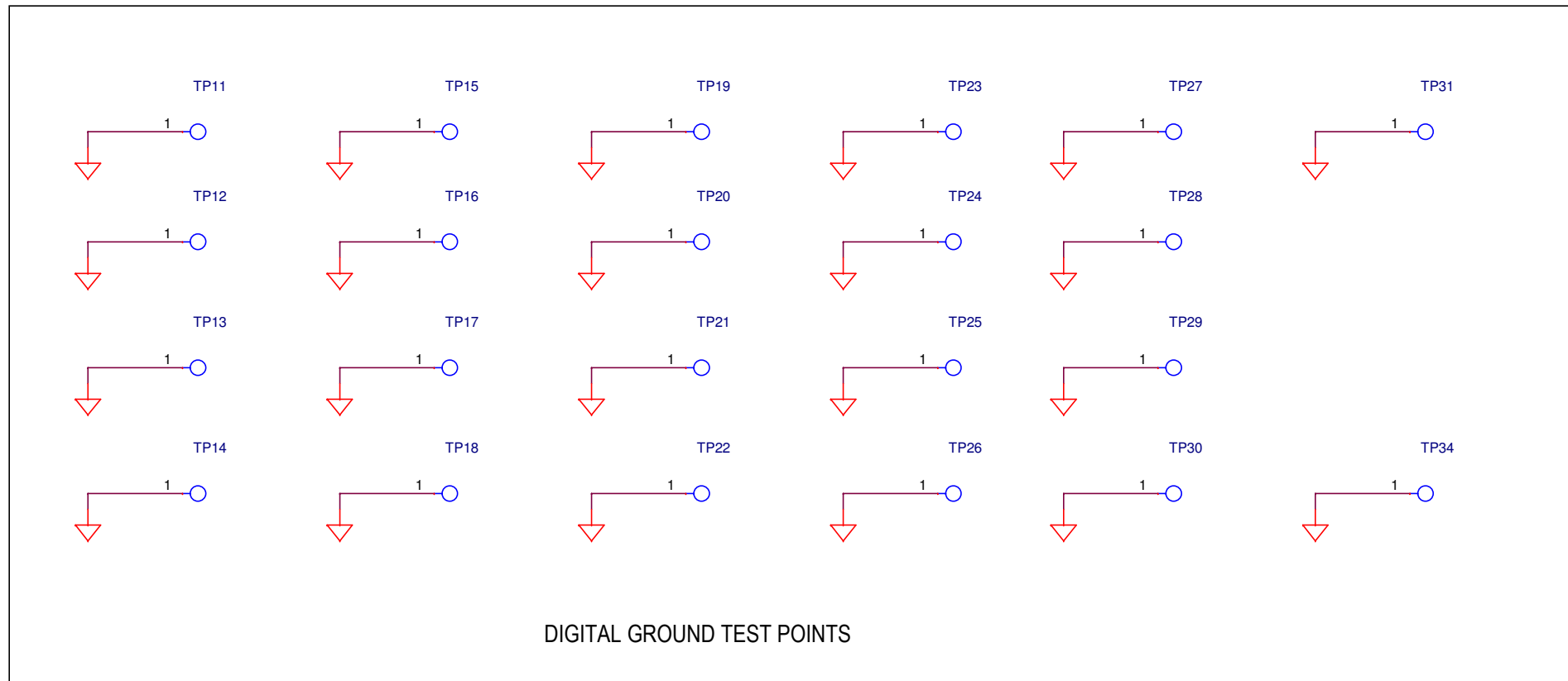
UNLESS OTHERWISE SPECIFIED:  
 RESISTORS ARE 0402 PACKAGE, POWER RATING < 0.5W & TOLERANCE > 1%  
 CAPACITORS ARE 0402 PACKAGE & TOLERANCE OF 10%



 <b>OpenCellular</b>	DOCUMENT NUMBER: 232-000036	
	TITLE: LT4231_LACID	LIFE 3

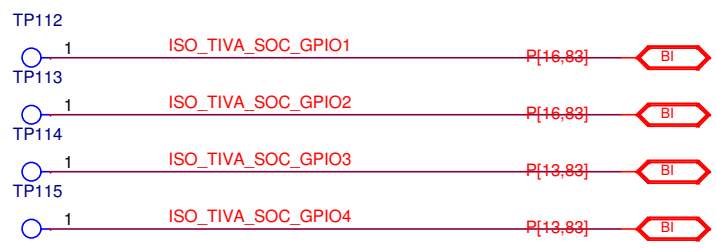
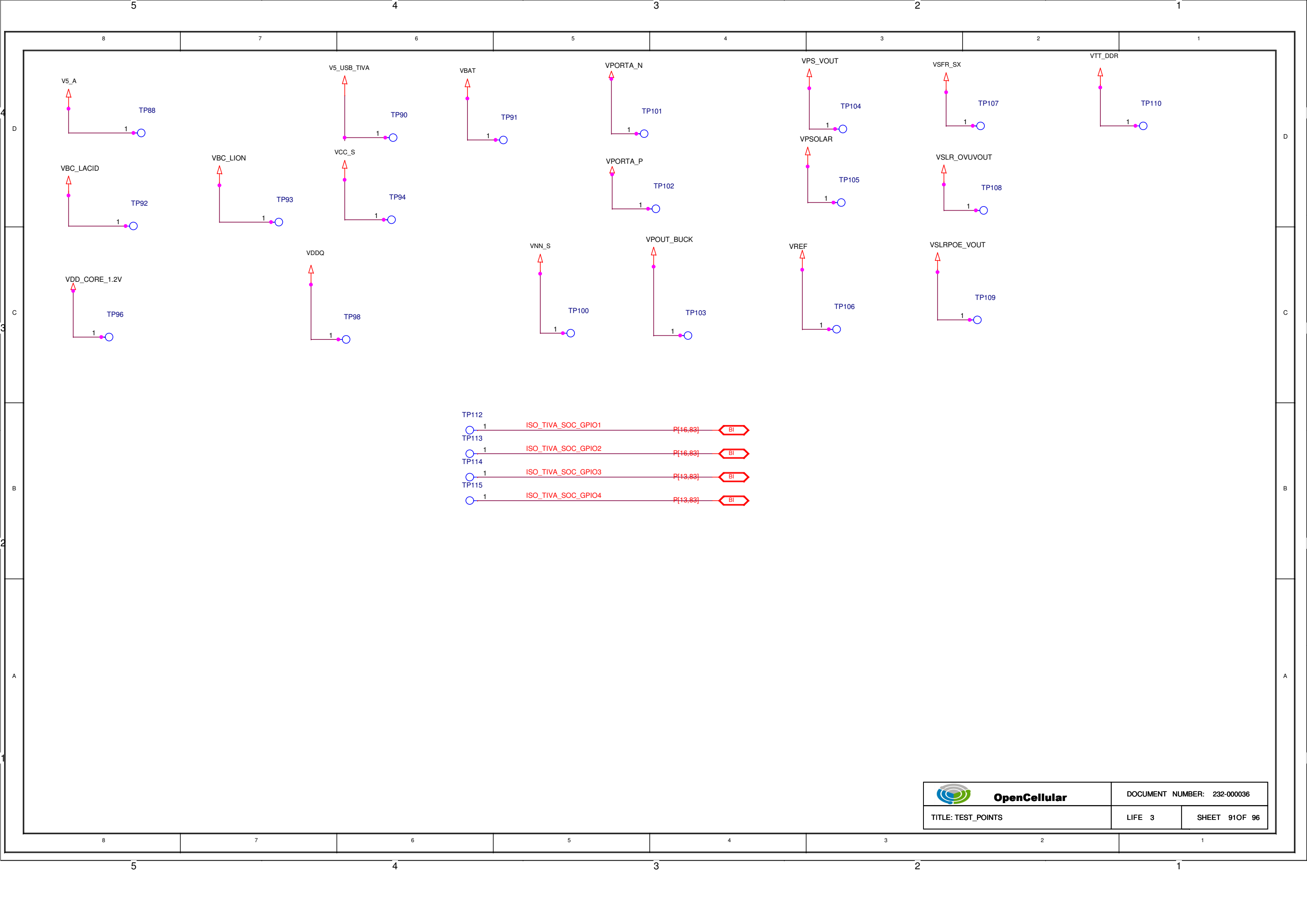




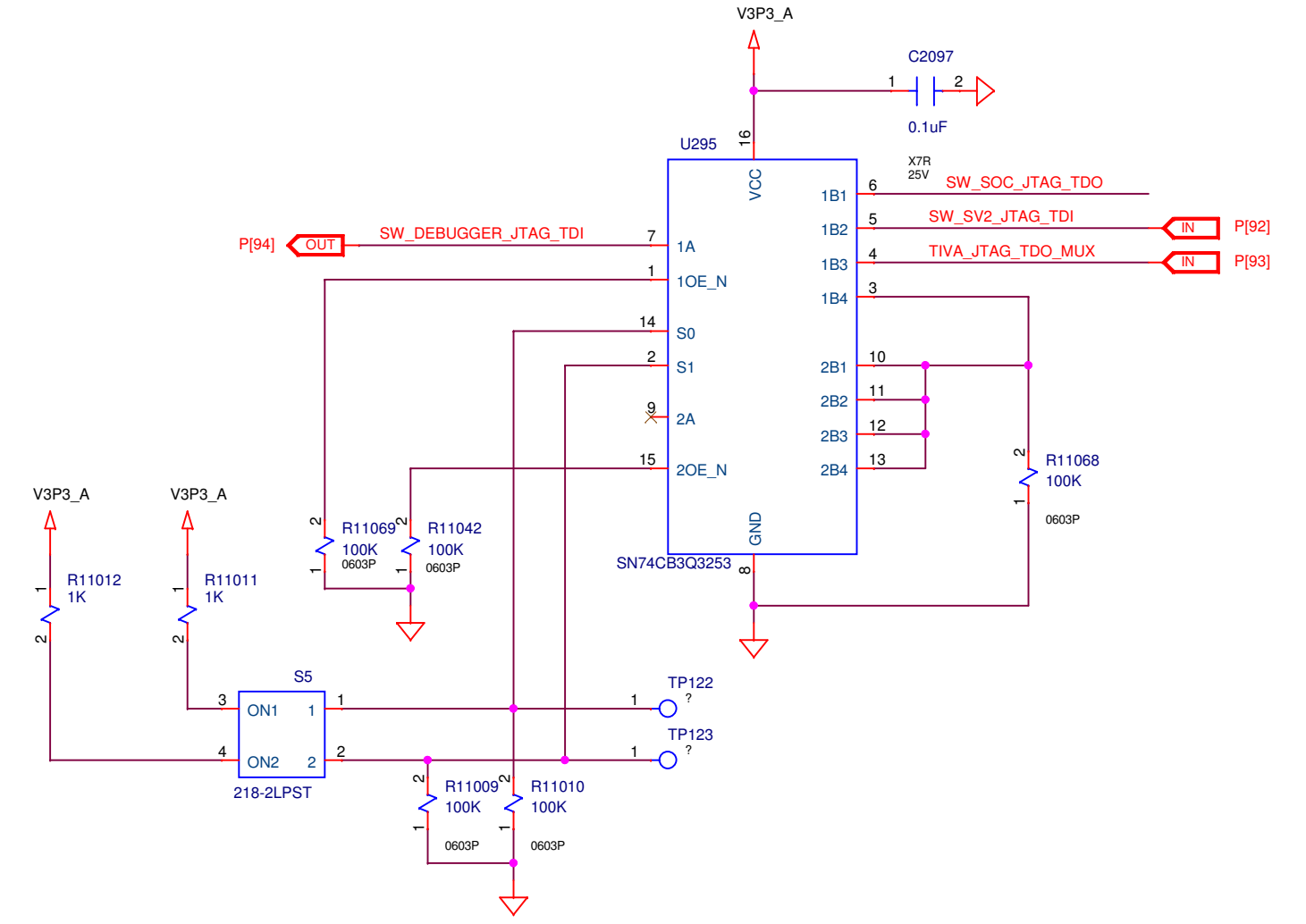
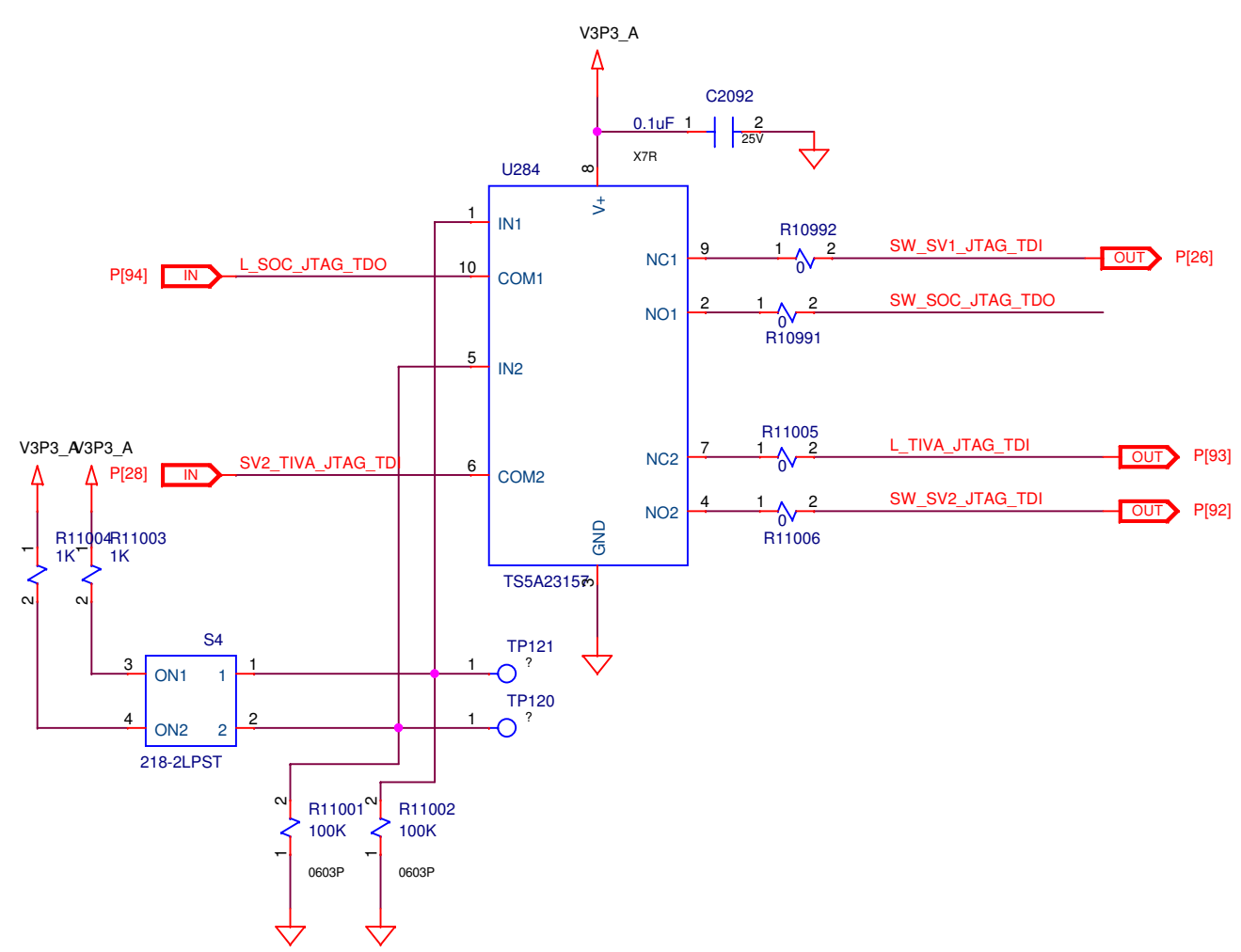


	DOCUMENT NUMBER: 232-000036	
	LIFE 3	SHEET 90OF 96

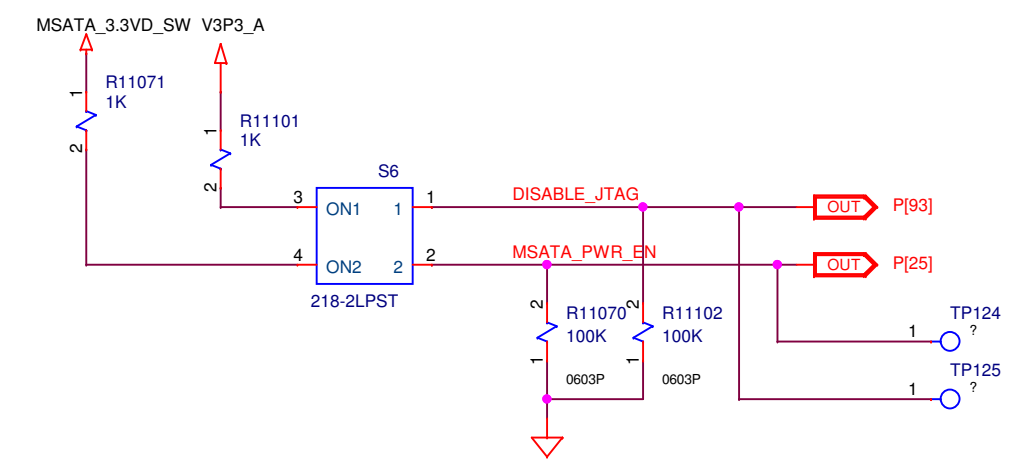
TITLE: TEST\_POINTS



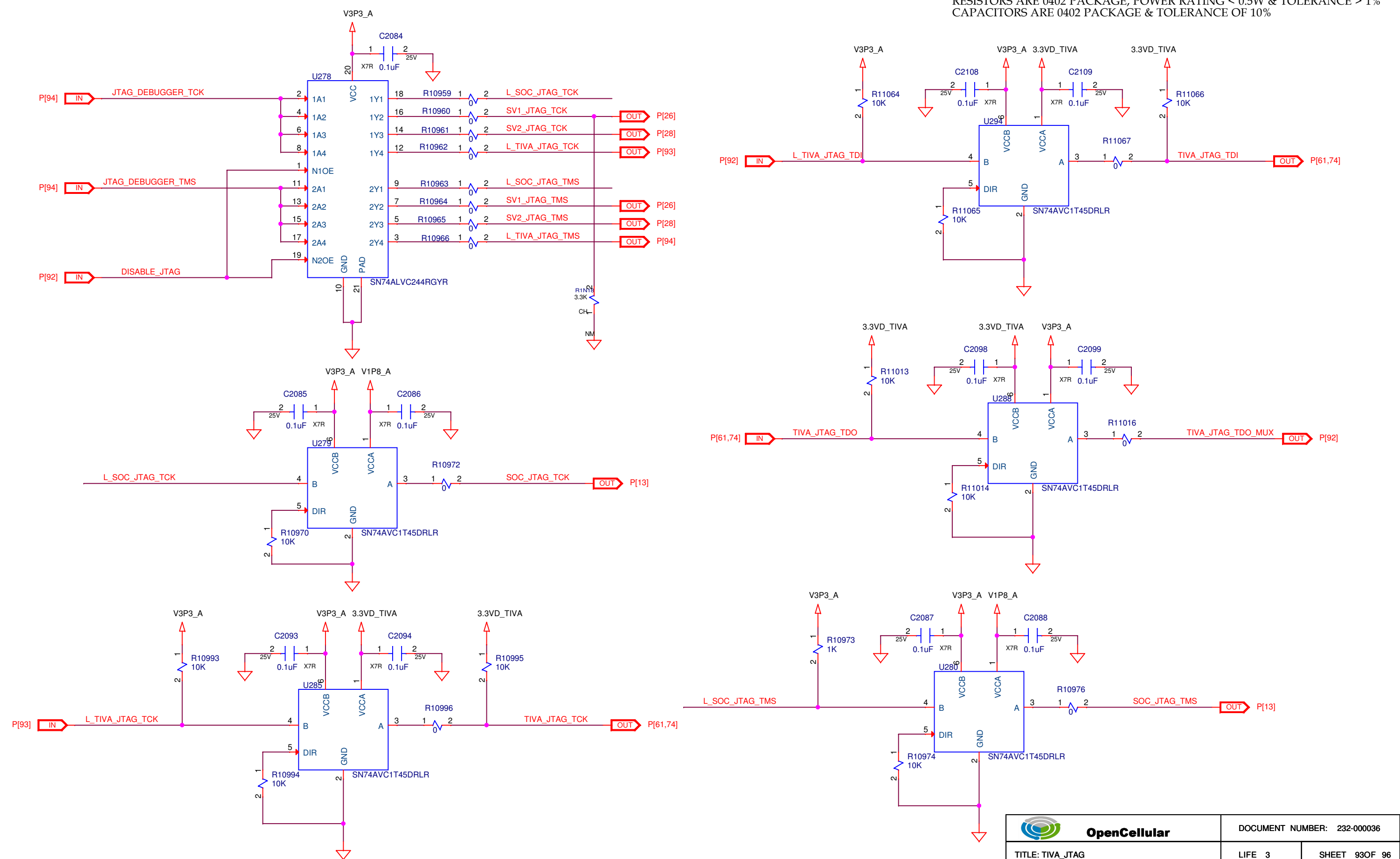
UNLESS OTHERWISE SPECIFIED:  
 RESISTORS ARE 0402 PACKAGE, POWER RATING < 0.5W & TOLERANCE > 1%  
 CAPACITORS ARE 0402 PACKAGE & TOLERANCE OF 10%



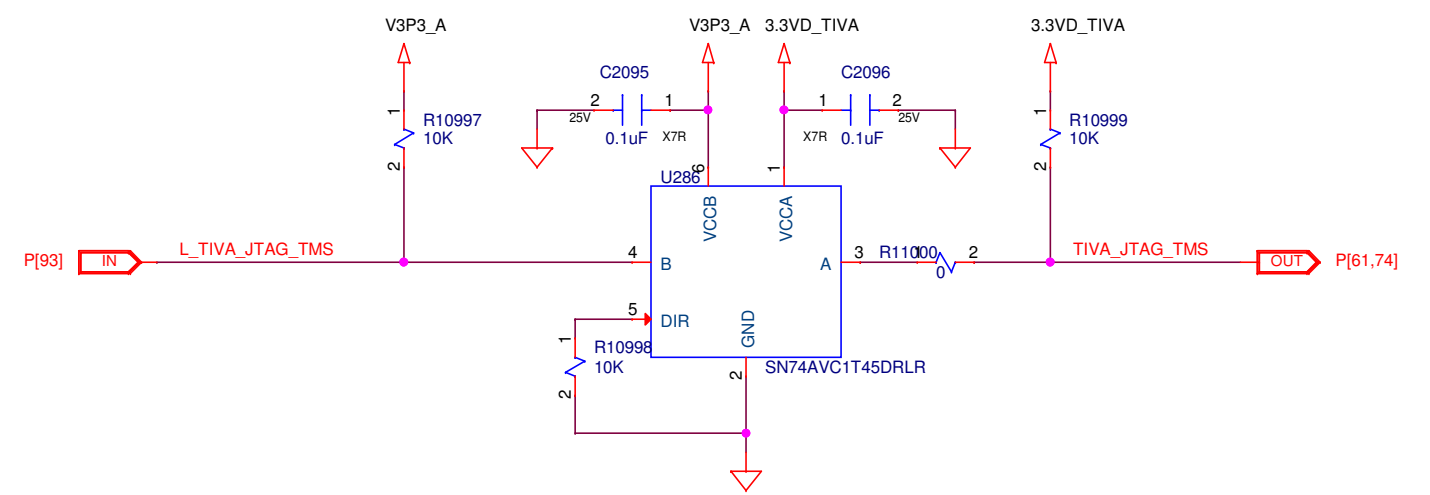
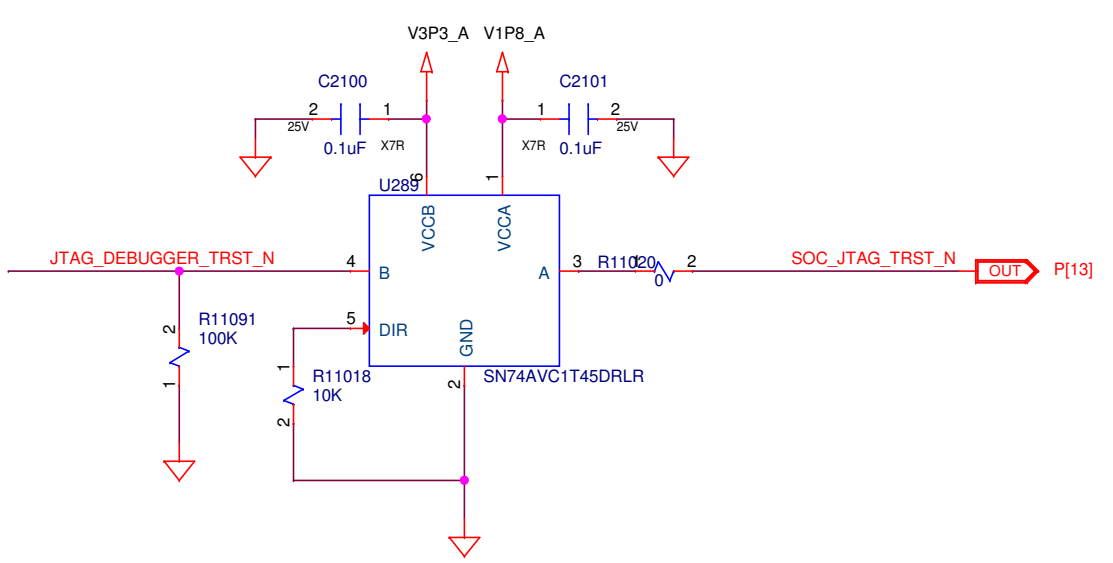
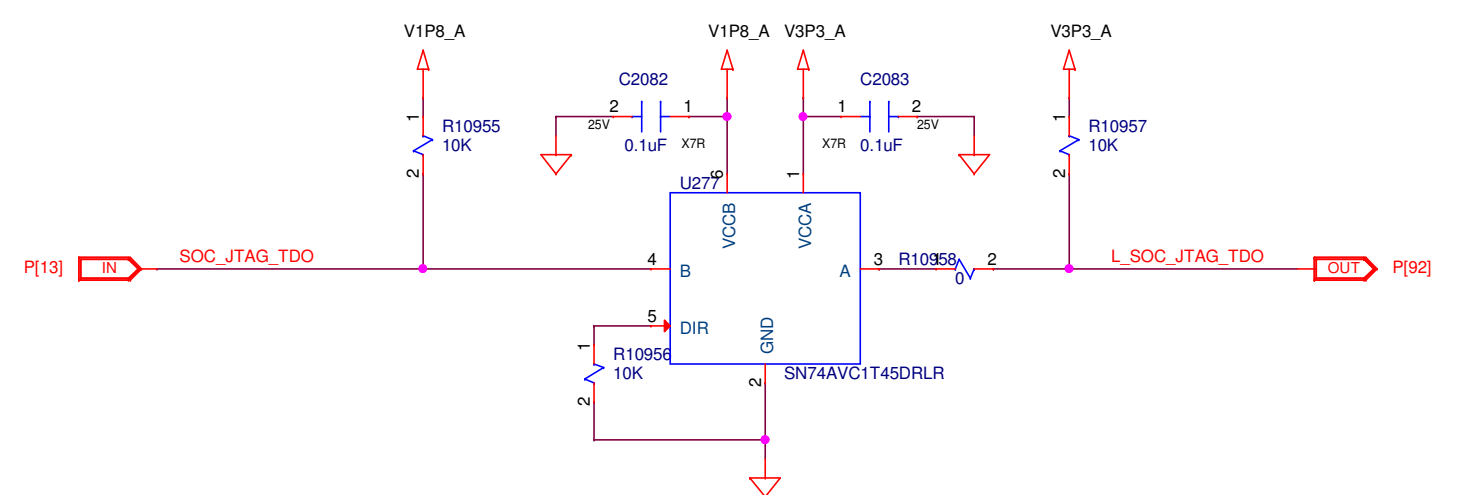
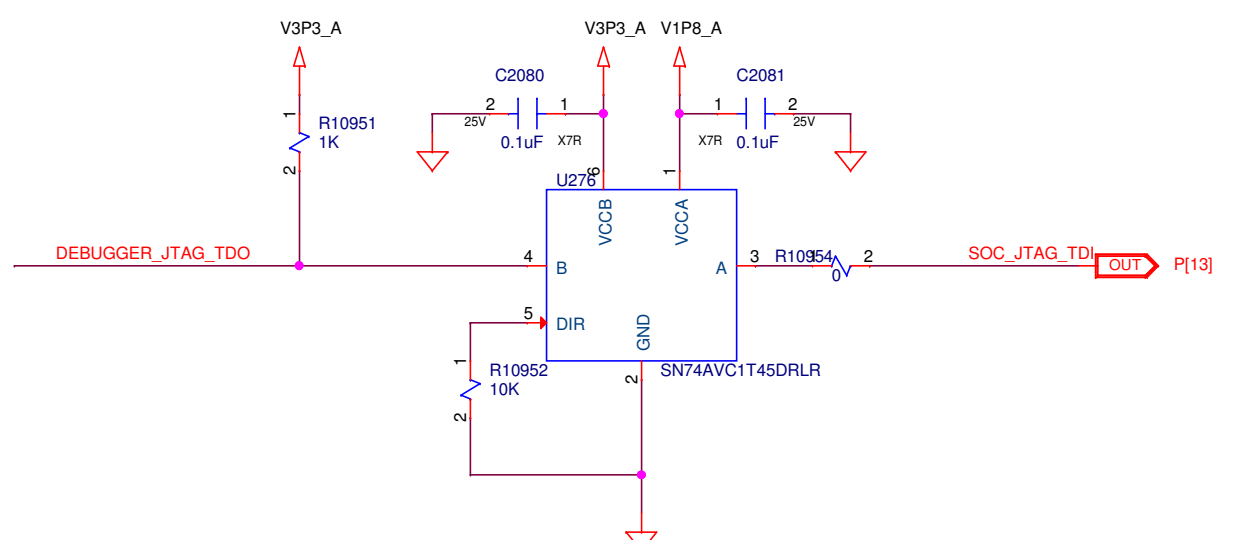
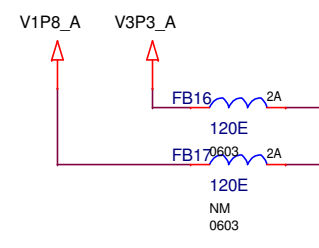
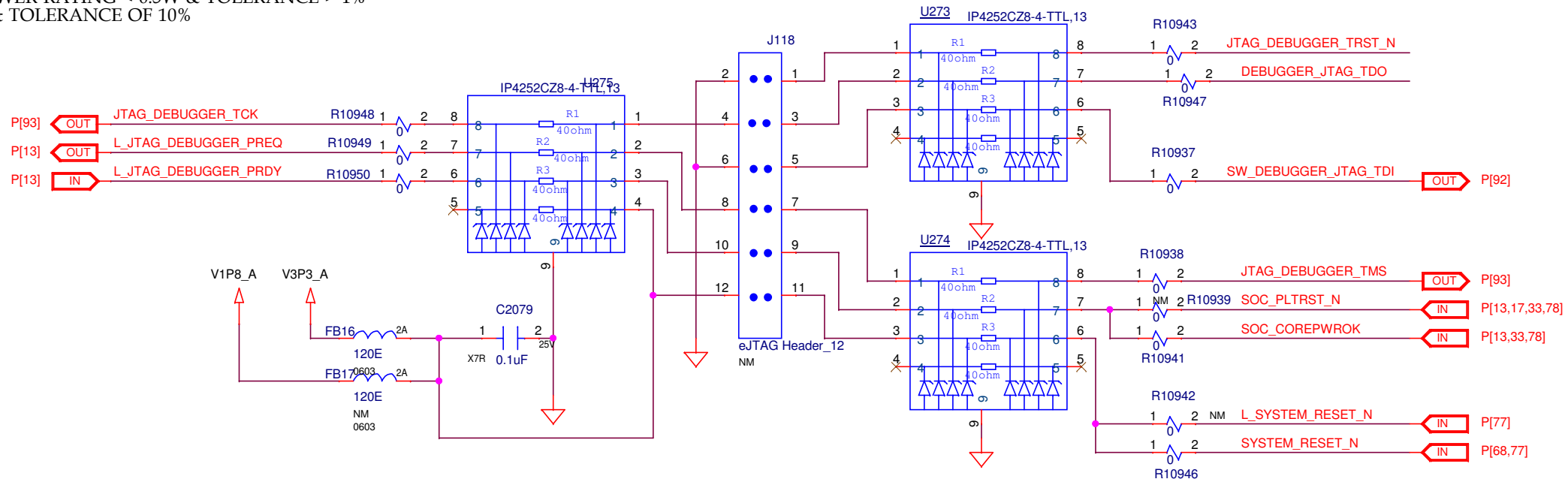
SI No	Switch Details	Intel ONLY	Intel + Springville 1 + Springville 2	TIVA ONLY	Intel + Springville 1 + Springville 2 + TIVA	JTAG DISABLED
1	1) S4 - 1 --> X 2) S4 - 2 --> X 3) S5 - 1 --> X 4) S5 - 2 --> X 5) S6 - 1 --> ON	Disabled	Disabled	Disabled	Disabled	JTAG DISABLED
2	1) S4 - 1 --> OFF 2) S4 - 2 --> OFF 3) S5 - 1 --> OFF 4) S5 - 2 --> ON 5) S6 - 1 --> OFF	Disabled	Disabled	Disabled	Enabled	Disabled
3	1) S4 - 1 --> ON 2) S4 - 2 --> OFF 3) S5 - 1 --> OFF 4) S5 - 2 --> OFF 5) S6 - 1 --> OFF	Enabled	Disabled	Enabled (via J7)	Disabled	Disabled
4	1) S4 - 1 --> OFF 2) S4 - 2 --> ON 3) S5 - 1 --> ON 4) S5 - 2 --> OFF 5) S6 - 1 --> OFF	Disabled	Enabled	Enabled (via J7)	Disabled	Disabled



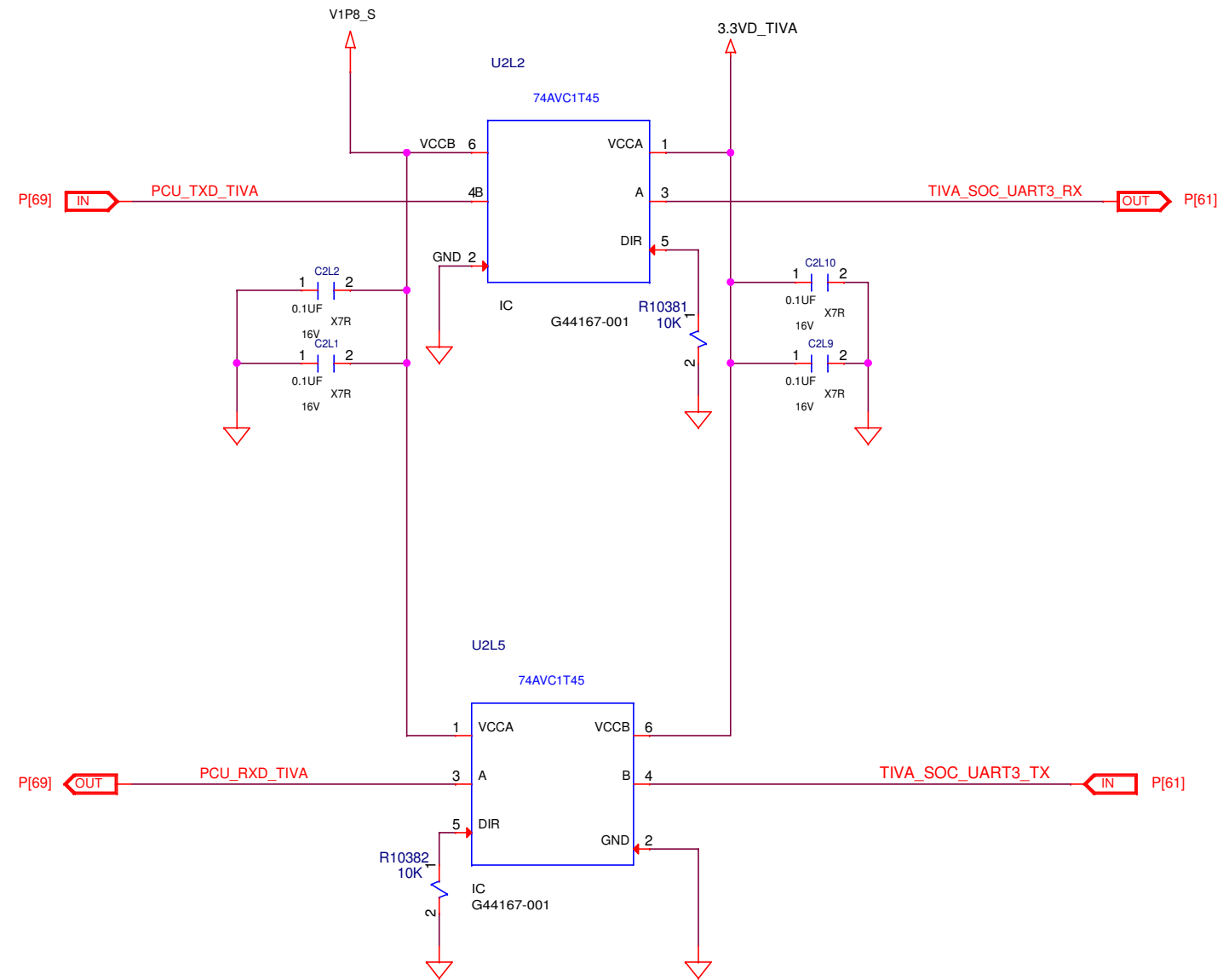
UNLESS OTHERWISE SPECIFIED:  
 RESISTORS ARE 0402 PACKAGE, POWER RATING < 0.5W & TOLERANCE > 1%  
 CAPACITORS ARE 0402 PACKAGE & TOLERANCE OF 10%



UNLESS OTHERWISE SPECIFIED:  
 RESISTORS ARE 0402 PACKAGE, POWER RATING < 0.5W & TOLERANCE > 1%  
 CAPACITORS ARE 0402 PACKAGE & TOLERANCE OF 10%



UNLESS OTHERWISE SPECIFIED:  
 RESISTORS ARE 0402 PACKAGE, POWER RATING < 0.5W & TOLERANCE > 1%  
 CAPACITORS ARE 0402 PACKAGE & TOLERANCE OF 10%



UNLESS OTHERWISE SPECIFIED:  
 RESISTORS ARE 0402 PACKAGE, POWER RATING < 0.5W & TOLERANCE > 1%  
 CAPACITORS ARE 0402 PACKAGE & TOLERANCE OF 10%

